

Study of a 100% Renewable Electricity System for Western Europe: an EROI-based analysis

Dissertation presented by
Thibault MARTINELLE , Sylvain RAMELOT

for obtaining the Master's degree in
Electro-mechanical Engineering and Electrical Engineering

Supervisor(s)
Hervé JEANMART, Gauthier LIMPENS

Reader(s)
Emmanuel DE JAEGER, Gian-Marco RIGNANESE

Academic year 2017-2018

Abstract

Renewable energies are going to become the dominant means of electricity generation during and after the energy transition. In Europe, wind and solar energies are the main sources to be exploited. Their production being inherently intermittent, more frequent unbalances are expected on the grid. In order to balance it, the flexibility of the remaining power plants, imports and exports, the storage and the curtailment of renewable energies will all have an important role. This study analyses the case of Western Europe and determines the types, the locations and the sizes of the storage needed, taking into account the power exchange capacities between countries, the curtailment and the flexibility of the power plants. A model, in the form of a large optimisation problem, has been specifically developed for this study. It balances the grid every hour while maximising the Energy Return On Investment (EROI) of the electricity production and storage. It also optimises the renewable energy and storage assets. The EROI is used as a metric because it is not biased by subsidy policies, interest rates or lobbies. The study highlights the key role of storage in Western Europe. To reach an EROI-optimal 100% renewable electricity system, 4.8 TWh of batteries and 152 TWh of gas storage coupled with a PtG power of 522 GW are needed. From the total production, 38% is stored before being consumed leading to a loss of 17% of the production. A doubling of the transmission capacities between countries leads to a decrease of 2.5% of the total energy invested with a decrease of 17% of the energy invested in the storage.

Acknowledgements

First of all, we would like to thank our thesis supervisors Professor Hervé Jeanmart, whose busy schedule was always extensible of a few hours to answer our numerous questions, and Gauthier Limpens, who always tremendously managed to monitor our work, even with thousands of miles between us.

Our gratitude goes to Professor Emmanuel De Jaeger and Professor Gian-Marco Rignanese as the second readers of this thesis.

We would also like to thank Elise Dupont for her help during the data collection and we are gratefully indebted to her for the precious advices she provided.

This work would not have been the same without the help of Thomas Gillis, who helped us to use the computational resources provided by the Consortium des Équipements de Calcul Intensif (CÉCI), funded by the Fonds de la Recherche Scientifique de Belgique (F.R.S.-FNRS) under Grant No. 2.5020.11.

We must express our gratitude to Véronique Dias, who reviewed our manuscript and gave us a valuable feedback.

Thank you to Agnès Martinelle, who kindly accepted to read countless pages of meaningless mathematics.

Finally, we would like to thank our families who supported us during these five years at the EPL.

Contents

List of abbreviations	IV
List of symbols	V
Introduction	1
1 Model description and implementation	5
1.1 Basis	5
1.2 Model description	5
1.2.1 Consumption	6
1.2.2 Production	6
1.2.3 Storage	8
1.2.4 Transmission	9
1.3 Implementation	9
1.3.1 Programming language and tools	9
1.3.2 Program structure	10
1.4 Mathematical description of the problem	11
1.4.1 Objective function	12
1.4.2 Constraints	15
1.4.3 Variable limits	18
2 Validation	21
2.1 Study cases	21
2.2 Results and discussion	21
3 Western Europe model	23
3.1 Objectives	23
3.2 Definition of the cells	23
3.3 Implementation of the cells and input data	28
3.3.1 Consumption	28
3.3.2 Actual production capacities	29
3.3.3 Wind turbines	29
3.3.4 PV panels	32
3.3.5 Hydroelectric power plants	34
3.3.6 Storage systems	35
3.3.7 Transmission line capacities and import	37
3.3.8 Gas grid	38
3.4 Limits and hypotheses	39
3.4.1 Definition of the cells	39
3.4.2 Consumption	39
3.4.3 Actual production capacities	39
3.4.4 Wind turbines	39

3.4.5	PV panels	40
3.4.6	Hydroelectric power plants	41
3.4.7	Storage systems	41
3.4.8	Transmission line capacities	41
4	Two-cell analysis: Germany & Benelux and France	42
4.1	Study 1: 100% RE electricity system	42
4.1.1	Energy investment	43
4.1.2	Production and annual exchanges	43
4.1.3	Energy flows	44
4.1.4	RE assets	46
4.1.5	Storage assets	49
4.2	Study 2: Impact of the exchange capacity	52
4.2.1	Energy investment	52
4.2.2	Production and annual exchanges	53
4.2.3	RE assets	54
4.2.4	Storage assets	55
4.3	Conclusion	57
5	Six-cell analysis: Western Europe	58
5.1	Study 1: 100% RE electricity system	58
5.1.1	Energy investment	58
5.1.2	Production and annual exchanges	59
5.1.3	Energy flows	61
5.1.4	RE assets	62
5.1.5	Storage assets	64
5.1.6	Electricity exchanges	72
5.1.7	EROI analysis	75
5.2	Study 2: Impact of the exchange capacities	76
5.2.1	Energy investment	76
5.2.2	Production and annual exchanges	77
5.2.3	Energy flows	79
5.2.4	RE assets	80
5.2.5	Storage assets	80
5.2.6	Electricity exchanges	82
5.3	Conclusion	82
	Conclusion	84
	A Model description and implementation	88
A.1	Tables	88
	B Validation	89
B.1	Tables	89
B.1.1	Grid	89
B.1.2	Offshore cell	89
B.1.3	Onshore cell	90
	C Western Europe model	91
C.1	Tables	91

D	Two-cell analysis: Germany & Benelux and France	94
D.1	Tables	94
D.2	Hourly analysis	95
D.3	Study 3: Impact of the RE share	96
D.3.1	Renewable assets	98
D.3.2	Storage assets	99
D.3.3	Conclusion	100
E	Six-cell analysis: Western Europe	101
E.1	Tables	101
E.2	Graphs	102
	Bibliography	107

List of abbreviations

CAES	Compressed Air Energy Storage
CCGT	Combined Cycle Gas Turbine
EROI	Energy Return On (energy) Investment
ESOI	Energy Stored On (energy) Investment
LCOE	Levelized Cost of Energy
NTC	Net Transfer Capacity
PHES	Pumped Hydroelectric Energy Storage
PtG	Power to Gas
PV	Photovoltaic
RE	Renewable Energy
ROI	(money) Return On Investment
TRM	Transmission Reliability Margin
TTC	Total Transfer Capacity
WT	Wind Turbine

List of symbols

Variables

$E_{PV,i,c}$	Energy produced by the PV park i in cell c during period T	[Wh]
$P_{PV,i,c}(t)$	Power production of PV park i in cell c at time t	[W]
$area_{PV,i,c}$	PV installed surface in park i , cell c	[m ²]
$E_{WT,j,c}$	Energy produced by the WT park j in cell c during period T	[Wh]
$P_{WT,j,c}(t)$	Power production of WT park j in cell c at time t	[W]
$n_{WT,j,c}$	Number of installed WT in park j , cell c	
$P_{CCGT,c}(t)$	Power production of CCGT plants in cell c at time t	[W]
$E_{coal,c}$	Energy produced by the coal plants in cell c during period T	[Wh]
$P_{coal,c}(t)$	Power production of coal plants in cell c at time t	[W]
$E_{nuc,c}$	Energy produced by the nuclear plants in cell c during period T	[Wh]
$P_{nuc,c}(t)$	Power production of nuclear plants in cell c at time t	[W]
$E_{dam,c}$	Energy produced by the dam plants in cell c during period T	[Wh]
$P_{dam,c}(t)$	Power production of dam plants in cell c at time t	[W]
$E_{dam,c}(t)$	Energy stored in dam reservoirs in cell c at time t	[Wh]
$P_{dam,in,c}(t)$	Power inlet from local inflow in dams in cell c at time t	[W]
$E_{runriver,c}$	Energy produced by the run-of-the-river power station in cell c during period T	[Wh]
$P_{runriver,c}(t)$	Power production of run-of-the-river power stations in cell c at time t	[W]
$E_{b,k,c}(t)$	Energy stored in battery park k in cell c at time t	[Wh]
$P_{b,in,k,c}(t)$	Power inlet of battery park k in cell c at time t	[W]
$P_{b,out,k,c}(t)$	Power outlet of battery park k in cell c at time t	[W]
$E_{b,max,opt,k,c}$	Optimal battery storage size in park k , cell c	[Wh]
$E_{PHES,c}(t)$	Energy stored in PHES in cell c at time t	[Wh]
$P_{PHES,in,c}(t)$	Power inlet of PHES in cell c at time t	[W]
$P_{PHES,out,c}(t)$	Power outlet of PHES in cell c at time t	[W]
$P_{PtG,c}(t)$	Power inlet of PtG in cell c at time t	[W]
$P_{PtG,max,opt,c}$	Optimal PtG installed capacity in cell c	[W]
$P_{PtG,inst,opt,c}$	Optimal installed PtG capacity in cell c	[W]
$E_{gas,c}(t)$	Energy stored in gas storage in cell c at time t	[Wh]
$E_{gas,max,opt,c}$	Optimal gas storage size in cell c	[Wh]
$E_{cons,c}$	Energy consumed in cell c during period T	[Wh]
$P_{cons,c}(t)$	Power consumed in cell c at time t	[W]
$E_{imp,c}$	Electrical energy imported from the outside of the system in cell c during period T	[Wh]
$P_{imp,c}(t)$	Electrical power imported from the outside of the system in cell c at time t	[W]
$E_{CCGT,imp,c}$	Energy produced by the CCGT plants from the gas imported from the outside of the system in cell c during period T	[Wh]
$P_{imp,gas,c}$	Gas imported power in cell c from the outside of the system	[W]

$P_{gas,exch,c_n,c}(t)$	Gas power exchanged from the neighbour cell c_n to the current cell c	[W]
$P_{gas,exch,c,c_n}(t)$	Gas power exchanged from the current cell c to the neighbour cell c_n	[W]
$P_{e,exch,c_n,c}(t)$	Electric power exchanged from cell c_n (neighbour) to the current cell c at time t	[W]
$P_{e,exch,c,c_n}(t)$	Electric power exchanged from the current cell c to the neighbour cell c_n at time t	[W]

Parameters

T	Period over which the model is studied	[h]
RE_{share}	Minimum RE share in the system	
Imp_{share}	Maximum import share in the system	
$RE_{share,c}$	Minimum RE share in cell c	
$Imp_{share,c}$	Maximum external import share in cell c	
$\gamma_{k,c}$	Self-discharge rate of battery park k in cell c	[1/h]
$\eta_{b,in,k,c}$	Input efficiency of battery park k in cell c	
$\eta_{b,out,k,c}$	Output efficiency of battery park k in cell c	
$\varepsilon_{inst,k,c}^b$	Energy investment cost per Wh of battery in park k , cell c for the period T	[Wh/Wh]
$\varepsilon_{ut,k,c}^b$	Energy investment cost per Wh stored in battery in park k , cell c for the period T	[Wh/Wh]
$E_{cost/Wh,k,c}^b$	Energy investment cost per Wh of battery in park k , cell c	[Wh/Wh]
$E_{LT/Wh,k,c}^b$	Energy storable per Wh of battery throughout its lifetime in battery in park k , cell c	[Wh/Wh]
$DoD_{b,k,c}$	Depth of discharge of battery park k cell c	
$n_{cycle,k,c}^b$	Maximum number of cycles of battery park k in cell c	
$E_{b,min,k,c}$	Already-installed batteries in battery park k , cell c	[Wh]
$E_{b,max,k,c}$	Maximum capacity of batteries in battery park k , cell c	[Wh]
$\alpha_{b,in,k,c}$	Charge rate of battery park k in cell c	[W/Wh]
$\alpha_{b,out,k,c}$	Discharge rate of battery park k in cell c	[W/Wh]
$\eta_{PHES,in,c}$	PHES input efficiency in cell c	
$\eta_{PHES,out,c}$	PHES output efficiency in cell c	
$ESOI_{PHES,c}$	ESOI of PHES in cell c	[Wh/Wh]
$E_{PHES,max,c}$	Size of the reservoir of the PHES in cell c	[Wh]
$E_{PHES,min,c}$	Minimum filling of the reservoir of the PHES in cell c	[Wh]
$P_{PHES,inst,out,c}$	PHES installed turbine capacity in cell c	[W]
$P_{PHES,inst,in,c}$	PHES installed pumping capacity in cell c	[W]
$\eta_{PtG,c}$	PtG input efficiency in cell c	
$\alpha_{PtG,c}$	PtG minimal utilisation in cell c	
$\varepsilon_{inst,c}^{PtG}$	Energy investment cost per W of PtG installed capacity in cell c for the period T	[Wh/W]
$\varepsilon_{ut,c}^{PtG}$	Energy investment cost per Wh entering the PtG in cell c	[Wh/Wh]
$E_{cost/W,c}^{PtG}$	Energy investment cost per W of PtG installed capacity in cell c	[Wh/W]
$E_{LT/W,c}^{PtG}$	Total convertible energy of the PtG throughout its lifetime in cell c	[Wh]
$n_{hour,c}^{PtG}$	Full load lifetime of the PtG in cell c	[h]
$P_{PtG,inst,min,c}$	PtG already-installed capacity in cell c	[W]
$P_{PtG,inst,max,c}$	Maximum PtG capacity in cell c	[W]
$\varepsilon_{inst,c}^{gas}$	Energy investment per Wh of gas storage installed capacity in cell c for the period T	[Wh/Wh]

$E_{gas,min,c}$	Already-installed gas storage in cell c	[Wh]
$E_{gas,max,c}$	Maximum gas storage capacity in cell c	[Wh]
$P_{imp,gas,max,c}$	Maximum gas import in cell c	[Wh]
$\eta_{CCGT,c}$	CCGT output efficiency in cell c	
$P_{CCGT,max,c}$	Installed CCGT production capacity in cell c	[W]
$P_{coal,max,c}$	Installed coal production capacity in cell c	[W]
$E_{dam,max,c}$	Size of the reservoir of the dam in cell c	[Wh]
$inflow_{dam,c}(t)$	Water inlet in the reservoir of the dam in cell c	[W]
$P_{dam,max,c}$	Installed dam power in cell c	[W]
$inflow_{runriver,c}(t)$	Water inlet in run-of-the-river power stations in cell c	[W]
$P_{runriver,inst,c}$	Run-of-the-river installed capacity in cell c	[W]
$\varepsilon_{i,c}^{PV}$	Energy investment per m^2 for PV in park i cell c for the period T	[Wh/ m^2]
$E_{cost/m^2,i,c}$	Energy cost per m^2 for PV in park i cell c	[Wh/ m^2]
$LT_{PV,i,c}$	PV lifetime in park i , cell c	[h]
$area_{PV,min,i,c}$	Already-installed PV surface in cell c	[m^2]
$area_{PV,max,i,c}$	PV available surface in cell c	[m^2]
$\varepsilon_{ij,c}^{WT}$	Energy investment per WT in park j cell c for the period T	[Wh/WT]
$E_{cost/WT,j,c}$	Energy cost per WT in park j cell c	[Wh/WT]
$LT_{WT,j,c}$	WT lifetime in park j , cell c	[h]
$n_{WT,min,j,c}$	Already-installed WT in cell c	
$n_{WT,max,j,c}$	WT technical potential of park j in cell c	[5MW _{eq}]
$P_{e,exch,max,c_n,c}$	Maximum electrical exchange capacity from cell c_n to the current cell c	[W]
$P_{e,exch,max,c,c_n}$	Maximum electrical exchange capacity from current cell c to the cell c_n	[W]
$P_{e,imp,max,c}$	Maximum electrical import capacity in cell c from the outside of the system	[W]
$P_{gas,exch,max,c_n,c}$	Maximum gas exchange capacity from cell c_n to the current cell c	[W]
$P_{gas,exch,max,c,c_n}$	Maximum gas exchange capacity from current cell c to the cell c_n	[W]
$P_{gas,imp,max,c}$	Maximum gas import capacity in cell c from the outside of the system	[W]

Introduction

The electricity sector of the industrialised countries is going through a phase of change and uncertainty. Indeed, to face climate change and the dependency on limited energy resources, governments encourage the increase of renewable production. Wind and solar powers will play an important role in this transition. However, the inherent intermittent behaviour of such energy sources raises new challenges in ensuring production and consumption adequacy. Energy storage appears as a promising solution allowing to balance supply and demand.

Different types of energy storage are available for different timescales and applications. Some of the most promising storage means are gathered in Figure 1.

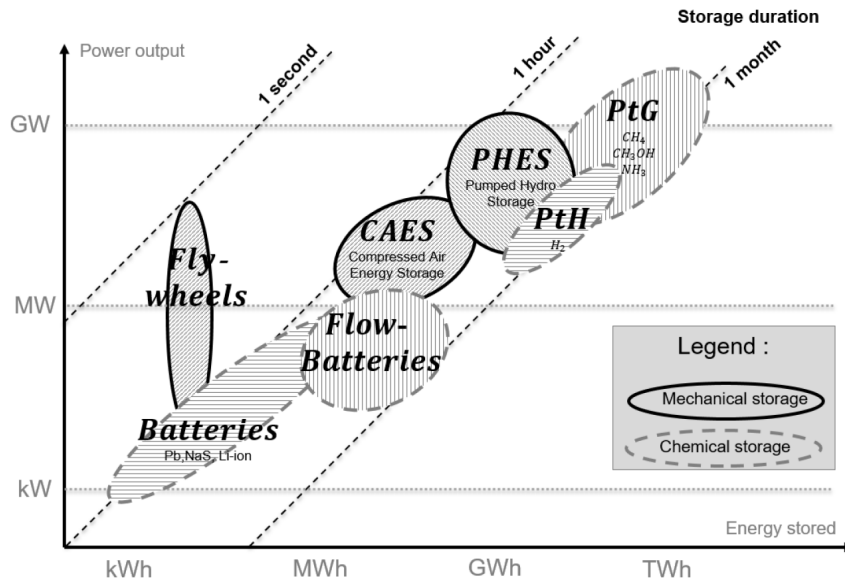

Figure 1: Fields of application of the different storage techniques according to energy stored and power output for a typical unit [71].

Three main categories are highlighted based on the timescale of the storage. These are short, mid and long-term storage corresponding respectively to periods of less than one day, between one day and several weeks and bigger than one month. In the short-term category, one can find flywheels, batteries and Compressed Air Energy Storages (CAES). Flywheels and CAES both consist in mechanical storage using respectively inertia and gas potential energy to store energy. Batteries, on the other hand, are chemical storage means involving a wide range of technologies used in the fabrication of accumulators (lithium-ion, sodium-sulfur, etc.). The other three technologies, i.e. Pumped Hydroelectric Energy Storage (PHEs), Power to Gas (PtG) and flow batteries, can be used to achieve mid-term storage. Flow batteries allow an increase of the energy stored with respect to power output compared to standard batteries, enabling higher storage capacity. PtG uses electrolysis phenomenon to produce hydrogen. This hydrogen can then be transformed under various forms (e.g. ammonia, methane, methanol) for better storage properties. It must be noticed that the terms "power to gas" and "gas storage" are used here

in a wide sense representing both gaseous and liquid fuels. PHES is a gravity-based storage using the potential energy of a water column. Only PtG allows long-term storage (i.e. seasonal storage). Indeed, PtG offers the possibility to store a significant amount of energy. Among all these different technologies, the optimal storage mix to allow the integration of intermittent renewable energy sources will have to be determined.

This study will focus on the Western Europe electricity system. This area allows to analyse a system with numerous countries being important electricity consumers and well-interconnected with various energy mixes. In addition, the different geographical configurations as well as the discrepancy between the north and the south define diversified consumption profiles and renewable potentials.

The European Union has the objective to cut its greenhouse gas emissions to 80-95% below 1990 levels by 2050 [20]. Different milestones have been set to reach this objective: a reduction of 40% below 1990 levels by 2030 and 60% by 2040. European authorities highlighted in their Roadmap to 2050 the key role of the electricity sector for decarbonising the European economy [21]. Moreover, focusing on their national territory, several agencies reported that a 100% renewable electricity system is, by 2050, technically as well as economically feasible [2, 65, 77]. The current share of electricity production covered by renewable generation is presented in Figure 2. It appears that several countries such as Norway, Denmark, Austria or Switzerland have already a high share of renewable in their electricity production due to strong hydroelectric or high wind production. However, most of the other countries of Western Europe still have a production mainly based on fossil fuels or nuclear power.

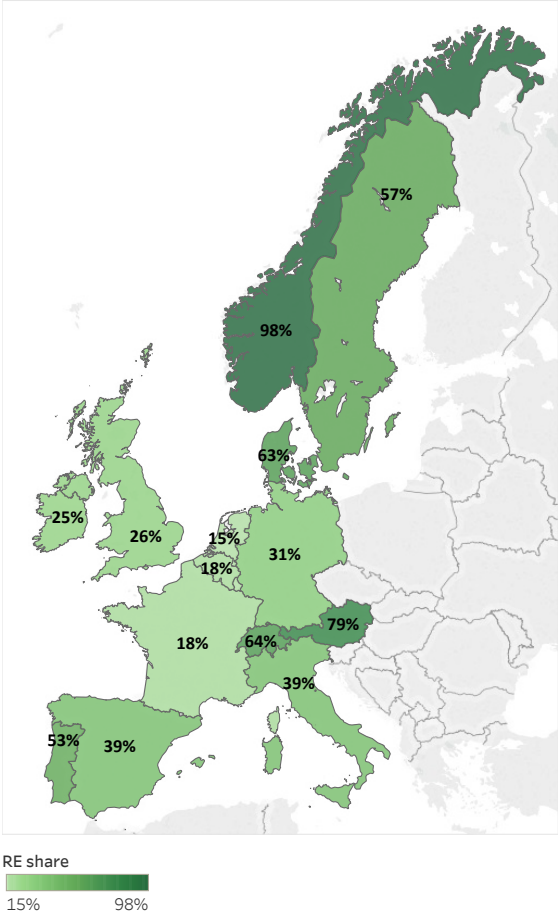

Figure 2: Share of electricity production covered by renewable generation in 2016. Adapted from [48–62].



Figure 3: Level of interconnection of the countries under study as a percentage of their production in 2017. Adapted from [33].

Moreover, as stated by the European Commission in [19] and detailed in [87]: "To achieve its climate and energy goals, Europe needs to improve cross-border electricity interconnections. Connecting Europe's electricity systems will allow the EU to boost its security of electricity supply and to integrate more renewable into energy markets". For this reason, the European Council called in October 2014 for all the EU countries to achieve interconnection of at least 10% of their installed electricity production capacity by 2020 which was extended to 15% by 2030. Figure 3 shows the level of interconnection of Western Europe in 2017 in percentage of their installed production capacity and most of them still have a low interconnection (between 6-10 % of their production capacity).

In order to analyse the electricity system of Western Europe, a model has been developed based on [71]. The tool developed in Python models the electricity system of a given area (city, countries, continents) for a given period (day, month, year). The area is divided in several cells presenting their own characteristics (e.g. production mix, renewable potential, policies) and interacting with each other through energy exchanges. This tool uses linear programming to determine the quantity and type of storage and renewable energy (RE) assets that have to be implemented in order to optimise the global electricity system for a given transition scenario. In opposition to numerous other studies about the power system of tomorrow which are based on economic factors as the Levelized Cost of Energy (LCOE) or the money Return On Investment (ROI) [1, 12, 15, 22, 72, 85], this study uses the Energy Return On Investment (EROI) metric as objective function, which has to be maximised.

The EROI is defined as the ratio of the useful energy delivered from a process to the energy required to get it [43]. This metric is here applied to renewable electricity production. In the following lines, the term curtailment is used. "Curtailment is a reduction in the output of a generator from what it could otherwise produce given available resources" [13]. A difference is made between gross and net EROI. The gross EROI corresponds to the energy that could have been produced by the renewable sources (including the energy curtailment) divided by the energy invested for those sources. On the other hand, the net EROI corresponds to the energy consumed by the end users coming from renewable sources divided by the energy invested for the RE and storage assets.

$$\text{EROI}_{\text{gross}} = \frac{\text{Energy possibly produced}}{\text{Energy invested in RE assets}}$$

$$\text{EROI}_{\text{net}} = \frac{\text{Energy consumed}}{\text{Total energy invested}}$$

In comparison with the gross EROI, the net EROI considers the curtailment, the energy cost of the storage and the storage efficiency. Therefore, the gross EROI is higher or equal to the net EROI. Taking a wind turbine as an example, the gross EROI is the ratio of the energy possibly produced during its lifetime if no curtailment was performed to the energy invested in the asset (manufacturing, commissioning, maintenance and dismantling). On the other hand, the net EROI is the ratio of the energy consumed from the wind turbine by the end user (considering curtailment and storage losses) to the total energy invested in the turbine and the storage. In this study, it is the net EROI that is maximised.

The EROI metric enables to avoid the influence of economic factors which are greatly impacted by policies, subsidies, lobbies, etc., while still taking into consideration present prices and future availabilities [43]. Moreover, the EROI is an interesting indicator because it is linked to the society welfare and the economic development [44, 67, 75]. Table 1 shows the average EROI of some renewable energy sources.

In order to model the Western Europe electricity system, different means of production are represented. Two intermittent renewable sources are implemented: wind turbines (WTs) and

Power generation system	Average gross EROI
Hydroelectricity	85
Photovoltaic panels	10
Wind Turbines	18

Table 1: Average gross EROI of renewable sources. Derived from [68].

photovoltaic (PV) panels. WTs as well as PV panels installed capacity is optimised by the model to maximise the net EROI. The other means of production are hydroelectric power stations, Combined Cycle Gas Turbine (CCGT), coal and nuclear power plants whose installed capacity is fixed. The choice of these assets is based on the actual European production mix where they represent the major part of the available electricity production. Three different means of storage are implemented: batteries, PHEs and PtG. These cover all the defined time scales with batteries for short-term, PHEs for mid-term and PtG for long-term storage. This storage mix is based on [71] and used in other studies [27, 40, 63, 72].

The goal of this analysis is to determine the optimal quantity and type of RE and storage assets that have to be installed in the case of a 100% RE electricity system. Moreover, the impact of the transmission line capacity on the optimal solution is studied. This work focuses on time scales ranging from one hour to one year. It has to be noticed that the tool developed has been implemented in a modular way, allowing to analyse many more study cases than the ones developed in the following lines (e.g. varying number of cells, transition scenarios, other electricity systems).

The work is organised as follows. First, a description of the model developed is introduced and the different production and storage assets implemented as well as the mathematical description of the optimisation problem are presented (Chapter 1). Second, a validation of the model is conducted based on the results of [71] (Chapter 2). Then, the definition of the cells representing Western Europe is presented as well as the data collection and processing achieved to characterise these cells (Chapter 3). Afterwards, the first study case on France, Germany and Benelux is analysed (Chapter 4). Finally, the second study concerning Western Europe is presented (Chapter 5).

Chapter 1

Model description and implementation

In this chapter, the model used to represent the system under study is detailed. First, the article [71] over which the tool developed is based is presented. Second, the model itself is introduced as well as the structure of the program. Finally, the mathematical description of the model is explained.

1.1 Basis

The model developed is based on the work of G. Limpens and H. Jeanmart presented in the article "*Electricity storage needs for the energy transition : an EROI based analysis illustrated for the case of Belgium*" [71]. The purpose of this research was to quantify the storage needs for the energy transition of Belgium. To do so, an hour-based model of the Belgium electricity system has been developed in order to optimise the RE and storage assets by maximising the EROI, while respecting power fluxes constraints.

A tool was provided under the form of a MATLAB program, using the linear programming solver `linprog`. Belgium electricity system is represented by two cells interacting with each other. The first cell corresponds to Belgium inland territory and the second corresponds to the offshore wind parks. These two cells are connected through a power line limiting the exchange between them. Several production sources and storage systems are implemented which can be found in Table 1.1.

The goal of the new model elaborated is to extend the analysis to the case of the Western Europe. To do so, a new program in Python has been developed. This program allows a variable number of cells, while for the previous one it was fixed to two. Furthermore, new production sources had to be introduced to represent the European energy mix. These can be found in Table 1.1. Coal is still highly used in lots of European countries, when in Belgium it has nearly disappeared [3]. It is then necessary to introduce it in the model. Hydroelectric production was neglected in the previous study, since dams and run-of-the-river power plants are marginal means of production in Belgium. In the actual model, this assumption is no longer possible since it represents approximately 16% of Western Europe electricity production [3].

1.2 Model description

The model studies the electricity system of a given area (city, countries, continents) for a given period (day, month, year) and time step. The area is divided in several cells. For the following, the term "*System*" refers to the complete electricity system under study, gathering all cells. Each cell includes producers, consumers and storage systems. The different cells can exchange energy

Production	MATLAB	Python
Nuclear	✓	✓
CCGT	✓	✓
Coal	×	✓
WT	✓	✓
PV panel	✓	✓
Dam	×	✓
Run-of-the-river	×	✓
Storage		
Batteries	✓	✓
PHES	✓	✓
PtG	✓	✓

Table 1.1: Production type in the MATLAB and Python program.

(electricity/gas) through transmission lines and pipelines, and the cells located at the border of the system can import electricity and gas from outside the system. The RE and storage assets of each cell as well as the production of the flexible generation means, the RE curtailment, the energy exchanges and the storage inputs and outputs are optimised in order to maximise the global EROI of the system for the period of time studied through a linear optimisation. A minimum percentage of renewable production compared to the total production is set at the level of the system and at the level of each cell. Furthermore, a given maximum percentage of electricity import from outside the system compared to the total electricity consumption is set, for the global system and for each cell.

Figure 1.1 represents a three-cell system. In this example, each cell is connected to all the others and only Cell 3 has an external electricity and gas connection. A cell is defined by a good interconnection for electricity and gas: the producers, consumers and storage systems are supposed well-connected. These three exchange energy without losses and with an unlimited transmission capacity. The cell is then seen as a copper plate. The cell is studied as one entity and defines then the spatial resolution of the model. Figure 1.2 represents a cell. The presented cell is connected to one other cell and to the outside of the system. As detailed hereafter, the production park of a cell is composed of RE assets (PV, WT and hydroelectric power plants) as well as conventional means of production (nuclear, coal and CCGT). Electricity can be stored in three different storage systems: batteries, PHES and gas storage (composed of a PtG unit and a storage system). CCGT units can consume gas from the storage or from the import. Finally, electricity is consumed inside a cell by local consumers.

The electric system can be divided in four components consumption, production, storage and transmission.

1.2.1 Consumption

One electricity consumption profile is defined for each cell of the system.

1.2.2 Production

The renewable electricity sources implemented are

- Photovoltaic panels
- Wind turbines (onshore and offshore)
- Dams
- Run-of-the-river power stations

The installed capacity of the PV panels and WTs is optimised by the system, while the

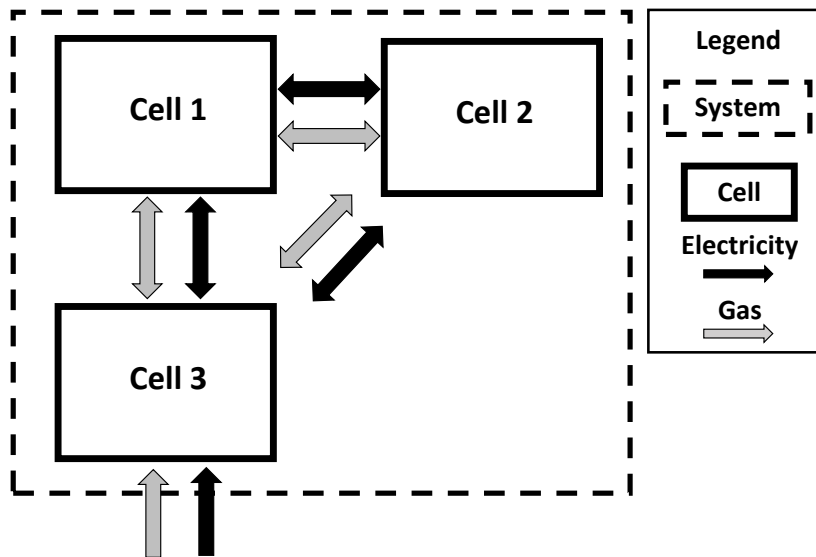

Figure 1.1: Representation of a three-cell system. Adapted from [71].

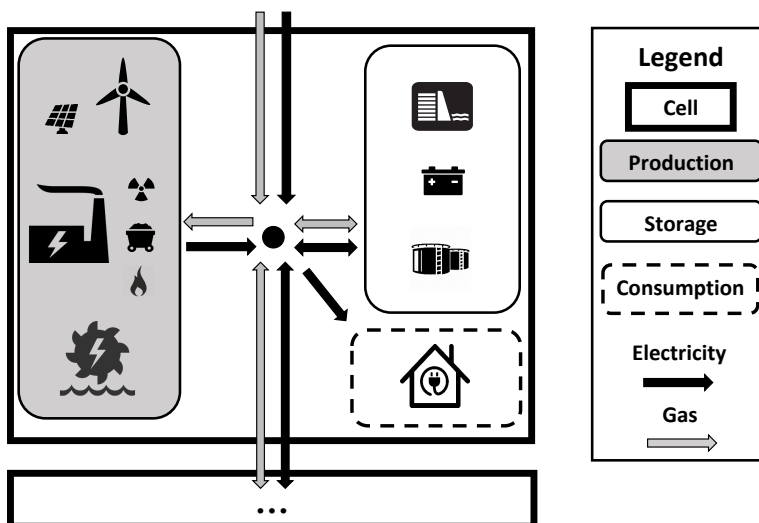

Figure 1.2: General representation of a cell. Adapted from [71].

hydroelectric capacity is not. The hydroelectric installed capacity is considered as a fixed quantity. Indeed, it is considered that the actual hydroelectric capacity of Western Europe is close to its maximum potential and is not expected to increase drastically in the coming years. Certain studies state that the European hydroelectric capacity represents only half of its potential [69, 84], but most of the remaining potential is located in Eastern Europe. The cells can have different PV and WT parks in order to take into account the different meteorological conditions inside the cell. The meteorological conditions are indeed considered identical throughout a given park.

The WT parks are characterised by a WT model (cut-in, cut-off and rated wind speed, rated power, lifetime and energy cost), wind speed data for the period studied, an average load factor, an already-installed capacity and a technical potential. The PV parks are characterised by a PV panel model (efficiency, lifetime and energy cost), irradiance data for the period studied, an average load factor, an already-installed capacity and a technical potential.

The Dams production type gathers all hydroelectric power plants possessing a water reservoir. This reservoir is filled by a water inlet with a given profile. The dams are summarised for each cell by a total installed storage capacity, local inflow data for the period studied and a total installed output power. The Run-of-the-river power stations represent hydroelectric generation plants with little or no water storage. The production of these is directly linked to the local inflow profile, since no water storage can be achieved. The run-of-the-river power stations are summarised for each cell by a total installed output power and local inflow data for the period studied.

The non-renewable (conventional) electricity producers are

- CCGT power plants
- Coal power plants
- Nuclear power plants

The CCGT and coal power plants can have a variable production over time, while nuclear plants have a constant production fixed at the installed power. The CCGT category groups the production of CCGT and other flexible plants such as biogas power plants. Those three energy generation systems are characterised by their total installed power for each cell and the fuel to electricity efficiency of the CCGT is also specified. The assumption of a non-flexible nuclear production is not respected for all countries. For example, in France, nuclear represents the major power supply and flexible nuclear units are available [10]. Concerning coal production, no ramp rate is taken into account, which implies that coal production can vary instantaneously.

1.2.3 Storage

The storage system used in the current model is inspired from the previous work focusing on Belgium presented in Section 1.1: "An ideal storage mix is composed of an efficient daily storage and a large energy reservoir seasonal storage. A mix of PHES, batteries and PtG is promising with high efficiency batteries for short-term, PHES depending on geography for mid-term and PtG for large energy storage and seasonal needs" [71]. Moreover, this kind of storage mix is also used in numerous studies [27, 40, 63, 72].

The electricity storage systems implemented are thus:

- Batteries
- Gas
- PHES

Batteries and gas storage installed capacity are optimised, while PHES capacity is not. As for the hydroelectric power plants, PHES already-installed capacity is considered close to its maximum potential and is not expected to increase drastically in Western Europe in the near future. However, studies state that potential can still be used in Europe for PHES [42]. The Gas storage system is composed of a PtG unit and a gas storage. The electricity is transformed into gas by the PtG unit, stored in the gas storage and then transformed in electricity via the CCGT

power plants. As stated in [71]: "The nature of the fuel and its chemical state (gas or liquid) are not specified in the model because only the quantity of chemical energy matters, independently of the fuel (natural gas, methanol, gasoline...)". It must be noticed that the terms "*power to gas*" and "*gas storage*" are used in a wide sense and could refer to both gaseous and liquid fuels, as mentioned in the introduction. Battery storage can be divided in different battery parks in a cell in order to have different types of batteries.

The storage systems are characterised by a storage capacity (E_{max}), a charge (α_{in}) and a discharge (α_{out}) rate, an input (η_{in}) and an output (η_{out}) efficiency, a depth of discharge (DoD) and a leak (γ) (see Figure 1.3).

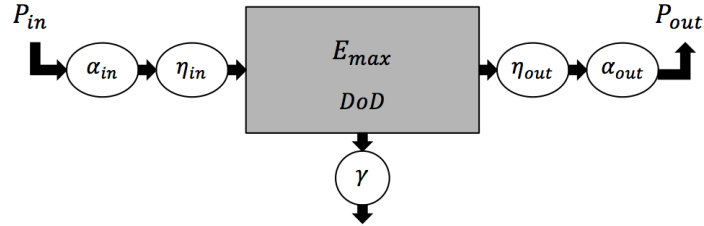

Figure 1.3: Representation of a storage system. Adapted from [41].

In addition to those parameters, the battery parks are characterised by the cost of the batteries, their maximum number of cycles, the already-installed capacity and a technical potential. The PtG and the gas storage are characterised by an energy cost and lifetime. The PHES is characterised by its Energy Stored On Investment (ESOI). "ESOI is the ratio of electrical energy stored over the lifetime of a storage device to the amount of primary embodied energy required to build the device" [11]:

$$\text{ESOI} = \frac{\text{Energy stored}}{\text{Embodied energy}} \quad (1.1)$$

1.2.4 Transmission

The transmission lines and pipes allow electricity and gas exchanges between neighbouring cells. The border cells can import electricity and gas from outside the system as well. Those electricity and gas exchanges are limited by a maximum exchange capacity and supposed without losses. The total electricity imported from outside the system is limited to a given percentage of the total consumption at the level of the system and at the level of each cell.

1.3 Implementation

In this section, the implementation of the model is detailed. This explanation is intended for people who would like to get familiar with the way the program is implemented and eventually reuse it. The source code of the program can be found in an online repository¹.

First, the programming language and the tools used are introduced. Afterwards, the structure of the program is explained.

1.3.1 Programming language and tools

The model is implemented using the Python programming language. This choice has been made for several reasons. First, Python, as opposed to MATLAB, is an open source language. This allows a wider spread of the study and a high reusability. Second, Python proposes high level

¹The repository is hosted on github at the following url: <https://github.com/sramelot/memoire2018>

libraries to solve linear optimisation problems in a simple and efficient way. MATLAB only gives access to a matrix-based interface when Python offers more user-friendly interfaces such as Pulp, PyMathProg or PySCIPOpt. Finally, these Python modules sometimes give the possibility to use different solvers, allowing a comparison between their computational times. That is why Pulp is used to interface the linear problem, allowing to use different free-access solvers such as CBC and SCIP or even commercial solvers such as CPLEX.

Because of the high computational power needed to run the simulations and to the number of different cases studied, clusters have been used. These computational resources have been provided by the Consortium des Équipements de Calcul Intensif (CÉCI).

1.3.2 Program structure

In this section, the structure of the program developed is explained. First, the structure of the system is introduced, followed by the structure of the cell with its means of production and storage.

System

The structure of the system can be seen in Figure 1.4. The system gathers all the cells, as well as the grid structure and the policies defined at the level of the system. The grid is a unique structure gathering all the parameters of the electricity and gas networks characterising the exchanges between cells and with the outside of the system. The cell can be instantiated multiple times, meaning that the system can be composed of one or more cells. The other structures of the system are unique.

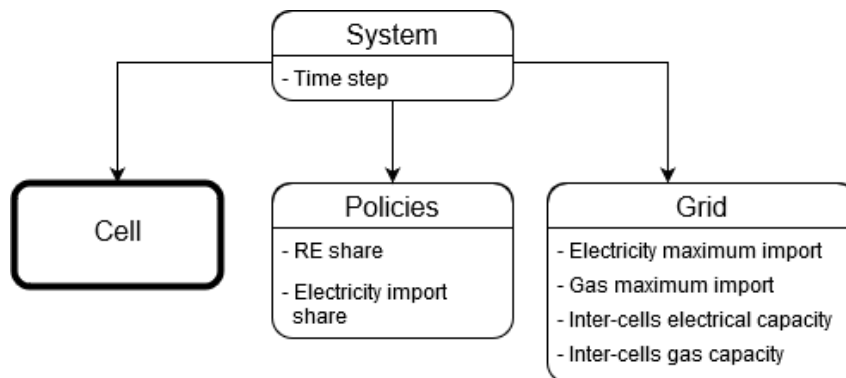

Figure 1.4: Main system structure, with each element of a list representing an input of the model. Bold boxes represent structures that can be instantiated more than once, other are unique.

Cell

The structure of a cell is detailed in Figure 1.5. In the same way as for the system, cells are characterised by policies acting at the level of the cell. As stated in Section 1.2, a cell has different production and storage assets. Moreover, each cell has a unique consumption profile.

Production and storage

Figures 1.6 and 1.7 represent the production and storage assets of a cell respectively. One can observe all the means of production and storage defined in Section 1.2. Each production asset is unique apart from WT park and PV park which can be instantiated multiple times. Looking at the storage assets, all are unique except battery park.

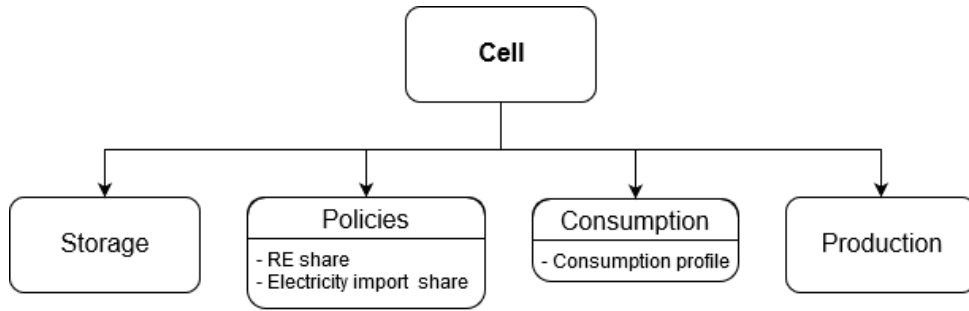

Figure 1.5: Cells structure, with each element of a list representing an input of the model.

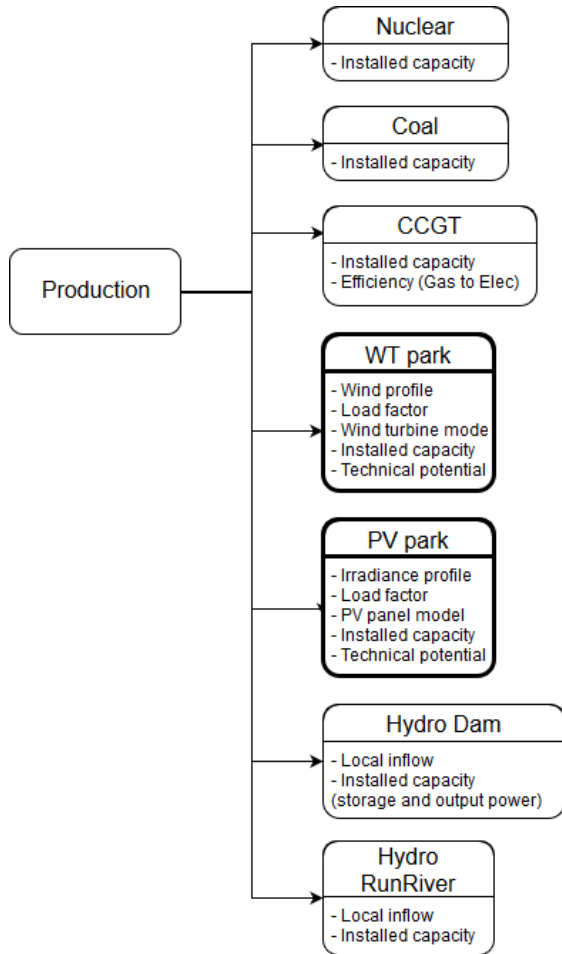

Figure 1.6: Structure of the production assets of a cell, with each element of a list representing an input of the model. Bold boxes represent structures that can be implemented more than once, other are unique structures.

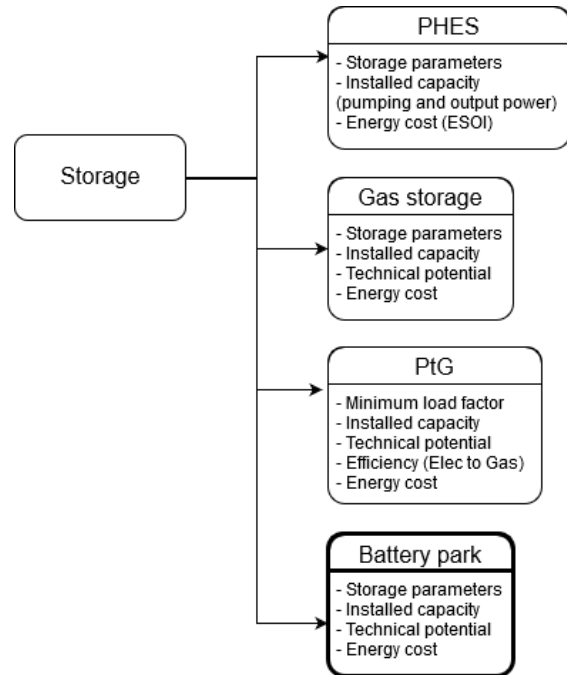

Figure 1.7: Cell storage implementation, with each element of a list representing an input of the model. Bold boxes represent structures that can be implemented more than once, other are unique structures.

1.4 Mathematical description of the problem

In this section, the mathematical representation of the problem is detailed. For the first of the following subsections, most of the parameters and variables are defined in the main text in order to facilitate the comprehension of the reader. For the other subsections, the variables and parameters

non-defined can be found in the list of symbols at the beginning of this document. Each one of these variables and parameters includes subscripts, defining a specific type of generation/storage in a specific cell. The cell is referred by the subscript c . When multiple sub-parks of a generation type can be installed, it will be indexed by a subscript i, j or k corresponding to a given PV, WT or battery park respectively. For more information on the subscripts, see Table A.1.

The problem is divided in three main parts: the objective function, the constraints and the variables limits. In the following lines t is an element of a time vector discretised with a time step Δt covering a period T , all expressed in hours. The powers $P(t)$ correspond to the average power over the time step $[t; t + \Delta t]$.

1.4.1 Objective function

The objective function is the function the solver has to minimise or maximise in order to reach the optimal solution. In the present case, the net EROI is maximised. As a reminder, the net EROI corresponds to the ratio of the end user consumption from renewable to the energy invested in renewable and storage assets:

$$\text{EROI}_{\text{net}} = \frac{\text{End user consumption from renewable}}{\text{Energy investment of RE and storage assets}} \quad (1.2)$$

Since the RE production share of the system is fixed as an input of the problem, the numerator in Equation 1.2 is constant. Maximising the net EROI is then equivalent to minimise the denominator that is to say minimise the sum of the energy invested in RE ($E_{\text{inv},RE}$) and in storage ($E_{\text{inv},stor}$) assets.

The energy investment of one unit of a RE asset corresponds to the total energy invested throughout the lifetime (production, installation, maintenance and dismantling) of this unit weighted by the fraction of its lifetime used during the period of study. For the following, the total energy invested throughout the lifetime of an asset is referred as the energy cost of that asset. With ε^{RE} the energy investment per unit, $E_{\text{cost},RE}$ the energy cost of one unit of RE asset, T the period of study and LT_{RE} the lifetime of the asset, one can write:

$$\varepsilon^{RE} = E_{\text{cost},RE} \frac{T}{LT_{RE}} \quad (1.3)$$

The total energy investment of the RE assets corresponds to the sum of the energy invested in PV panels and WTs in the system. As mentioned earlier, no cost is applied to the hydroelectric production. The energy investment per square meter of PV panel (ε^{PV}) and per unit of WT (ε^{WT}) are given by:

$$\varepsilon^{PV} = E_{\text{cost}/m^2} \frac{T}{LT_{PV}} \quad (1.4)$$

$$\varepsilon^{WT} = E_{\text{cost}/WT} \frac{T}{LT_{WT}} \quad (1.5)$$

with E_{cost/m^2} the energy cost of the PV panels expressed in Wh per square meter of panel and $E_{\text{cost}/WT}$ the energy cost of the WT expressed in Wh per WT. The total energy investment for the RE assets in a cell ($E_{\text{inv},RE,c}$) is then given by the sum of the energy invested in PV panels and WT in each park of the cell:

$$E_{\text{inv},RE,c} = \sum_i \overbrace{\left(\text{area}_{PV,i,c} \varepsilon_{i,c}^{PV} \right)}^{\text{PV park}} + \sum_j \overbrace{\left(n_{WT,j,c} \varepsilon_{j,c}^{WT} \right)}^{\text{WT park}} \quad (1.6)$$

The storage assets implemented in the model are batteries, PtG units, gas storage and PHES. The energy invested in the storage assets for the system ($E_{\text{inv},stor}$) corresponds thus to the

sum of the energy invested in each assets for each cell. The energy investment of one unit of a storage asset corresponds as well to the total energy invested throughout the lifetime of this unit weighted by the fraction of its lifetime used during the period of study. However, this investment can either be taken into account at the installation or at the utilisation. For the first option, the fraction of the lifetime used corresponds to the ratio of the period of study to the lifetime of the asset expressed as a period of time and is fixed no matter the amount of energy entering the storage. For the second option, the fraction used is expressed as the ratio of the energy stored during the period of study to the total energy storable by the asset throughout its lifetime. For batteries and PtG units, the energy investment is split between installation and utilisation by the mean of a weighting factor in order to avoid unrealistic behaviours such as a huge park of batteries only used once or a small park used all the time.

Regarding the batteries, the energy investment per Wh of battery installed accounted at the installation (ε_{inst}^b) is written as:

$$\varepsilon_{inst}^b = E_{cost/Wh}^b \frac{T}{LT_b} \quad (1.7)$$

with $E_{cost/Wh}^b$ the energy cost per Wh installed and LT_b the lifetime of the batteries. In order to compute the energy investment accounted at the utilisation, one has to express the total energy storable throughout the lifetime of the battery per Wh installed ($E_{LT/Wh}^b$). As detailed in [41]:

$$E_{LT/Wh}^b = \frac{DoD_b n_{cycle}^b}{\eta_{b,in}} \quad (1.8)$$

with DoD_b the depth of discharge, n_{cycle}^b the number of cycles that can be performed by the battery during its lifetime and $\eta_{b,in}$ the input efficiency. The energy invested per Wh entering the storage (ε_{ut}^b) is thus:

$$\varepsilon_{ut}^b = -\frac{E_{cost/Wh}^b}{E_{LT/Wh}^b} = -\frac{E_{cost/Wh}^b \eta_{b,in}}{DoD_b n_{cycle}^b} \quad (1.9)$$

A minus sign is placed because the energy entering the battery is considered negative. The total energy invested per Wh installed ($E_{inv,b/Wh}$) is then given by:

$$E_{inv,b/Wh} = \overbrace{w \varepsilon_{inst}^b}^{installation} + \overbrace{(1-w) \varepsilon_{ut}^b E_{in/Wh}^b}^{utilisation} \quad (1.10)$$

with $E_{in/Wh}^b$ the energy entered in the battery per Wh installed for the period of study and w the weighting factor between installation and utilisation with $0 < w < 1$. This weighting factor is fixed at $\frac{1}{2}$ in order to give an equal weight to installation and utilisation. $E_{in/Wh}^b$ can be rewritten as:

$$E_{in/Wh}^b = \sum_t P_{in/Wh}^b(t) \Delta t \quad (1.11)$$

with $P_{in/Wh}^b(t)$ the average power entering the storage over the period $[t; t + \Delta t]$.

The same method is applied in order to determine the energy investment of the PtG unit. The energy investment accounted at the installation per W installed ε_{inst}^{PtG} is expressed as:

$$\varepsilon_{inst}^{PtG} = E_{cost/W}^{PtG} \frac{T}{LT_{PtG}} \quad (1.12)$$

with $E_{cost/W}^{PtG}$ the energy cost per W installed and LT_{PtG} the lifetime of the PtG. The energy investment due to the utilisation per Wh entering the unit (ε_{ut}^{PtG}) equals the energy cost of the PtG per W installed divided by the total energy convertible throughout the lifetime of the unit per W installed. The total convertible energy per W ($E_{LT/W}^{PtG}$) is given by:

$$E_{LT/W}^{PtG} = n_{hour}^{PtG} \quad (1.13)$$

where n_{hour}^{PtG} corresponds to the full load lifetime expressed in hours. Then, one can write:

$$\varepsilon_{ut}^{PtG} = -\frac{E_{cost/W}^{PtG}}{n_{hour}^{PtG}} \quad (1.14)$$

A minus sign is placed because the energy entering the PtG unit is defined negative. The total energy invested per W installed ($E_{inv,PtG/W}$) is then given by:

$$E_{inv,PtG/W} = w\varepsilon_{inst}^{PtG} + (1-w)\varepsilon_{ut}^{PtG} E_{in/W}^{PtG} \quad (1.15)$$

with $E_{in/W}^{PtG}$ the energy entered in the PtG per W for the period of study and w the weighting factor between installation and utilisation with $0 < w < 1$. As for the batteries, w is fixed at $\frac{1}{2}$ in order to give an equal weight to installation and utilisation. $E_{in/W}^{PtG}$ can be rewritten as:

$$E_{in/W}^{PtG} = \sum_t P_{in/W}^{PtG}(t) \Delta t \quad (1.16)$$

with $P_{in/W}^{PtG}(t)$ the average power entering the unit over the period $[t; t + \Delta t]$.

Regarding the gas storage, a cost is only given at the installation:

$$\varepsilon_{inst}^{gas} = E_{cost/Wh}^{gas} \frac{T}{LT_{gas}} \quad (1.17)$$

with $\varepsilon_{inst,c}^{gas}$ the energy investment per Wh installed, $E_{cost/Wh}^{gas}$ the energy cost per Wh and LT_{gas} the lifetime of the gas storage.

For the PHES, a cost is only given at the utilisation using the ESOI. The ESOI, being the Energy Stored On (energy) Investment, the inverse corresponds to the energy cost per Wh stored:

$$\varepsilon_{ut}^{PHES} = \frac{1}{ESOI_{PHES}} \quad (1.18)$$

Finally, the total energy invested for the storage assets in a cell ($E_{inv,stor,c}$) is given by the sum of the energy invested for each battery park k , for the PtG, for the gas storage and for the PHES:

$$\begin{aligned} E_{inv,stor,c} = & \sum_k \frac{1}{2} \left(\overbrace{\left(\underbrace{\varepsilon_{inst,k,c}^b E_{b,max,opt,k,c}}_{\text{installation}} + \underbrace{\varepsilon_{ut,k,c}^b \sum_t (P_{b,in,k,c}(t) \Delta t)}_{\text{utilisation}} \right)}^{\text{battery park}} \right) \\ & + \frac{1}{2} \left(\overbrace{\left(\underbrace{\varepsilon_{inst,c}^{PtG} P_{PtG,max,opt,c}}_{\text{installation}} + \underbrace{\varepsilon_{ut,c}^{PtG} \sum_t (P_{PtG,in,c}(t) \Delta t)}_{\text{utilisation}} \right)}^{\text{PtG}} \right) \\ & + \overbrace{\varepsilon_{ut,c}^{PHES} \sum_t (P_{PHES,c}(t) \Delta t)}^{\text{PHES}} \\ & + \overbrace{\left(E_{gas,max,opt,c} \varepsilon_{inst,c}^{gas} \right)}^{\text{gas storage}} \end{aligned}$$

with $E_{b,max,opt,k,c}$ the installed battery capacity of park k , $P_{PtG,max,opt,c}$ the installed PtG power, $P_{PHES,c}(t)$ the power entering the PHES at time t and $E_{gas,max,opt,c}$ the installed gas storage capacity.

As said earlier, the total energy invested of the system corresponds to the sum of the energy invested in RE and storage assets of each cell. Thus, the objective function becomes:

$$E_{inv} = \sum_{Cell\ c} (E_{inv,RE,c} + E_{inv,stor,c}) \quad (1.19)$$

$$\begin{aligned}
&= \sum_{Cell\ c} \left[\left(\sum_i \overbrace{\left(area_{PV,i,c} \varepsilon_{i,c}^{PV} \right)}^{PV\ park} + \sum_j \overbrace{\left(n_{WT,j,c} \varepsilon_{j,c}^{WT} \right)}^{WT\ park} \right) \right. \\
&\quad + \sum_k \frac{1}{2} \left(\underbrace{\varepsilon_{inst,k,c}^b E_{b,max,opt,k,c}}_{\text{installation}} + \underbrace{\varepsilon_{ut,k,c}^b \sum_t (P_{b,in,k,c}(t) \Delta t)}_{\text{utilisation}} \right) \\
&\quad + \frac{1}{2} \left(\underbrace{\varepsilon_{inst,c}^{PtG} P_{PtG,max,opt,c}}_{\text{installation}} + \underbrace{\varepsilon_{ut,c}^{PtG} \sum_t (P_{PtG,in,c}(t) \Delta t)}_{\text{utilisation}} \right) \\
&\quad + \underbrace{\varepsilon_{ut,c}^{PHES} \sum_t (P_{PHES,c}(t) \Delta t)}_{\text{PHES}} \\
&\quad \left. + \underbrace{\left(E_{gas,max,opt,c} \varepsilon_{inst,c}^{gas} \right)}_{\text{gas storage}} \right] \quad (1.20)
\end{aligned}$$

1.4.2 Constraints

This section details all the constraints of the LP problem. The constraints are all the relations linking two or more variables.

Minimum RE share in system production

At the level of the system, a minimum share of renewable production is imposed. Equation 1.21 states that the sum of the renewable production of each cell has to be greater or equal to a given percentage of the total production and external import of the system.

$$\sum_{Cell\ c} \left(\sum_i E_{PV,i,c} + \sum_i E_{WT,i,c} + E_{coal,c} + E_{nuc,c} + E_{dam,c} + E_{runriver,c} + E_{CCGT,imp,c} + E_{e,imp,c} \right) \cdot \mathbf{RE}_{share} \leq \quad (1.21)$$

$$\sum_{Cell\ c} \left(\sum_i E_{PV,i,c} + \sum_i E_{WT,i,c} + E_{dam,c} + E_{runriver,c} \right)$$

with

$$E_X = \sum_t P_X(t) \Delta t \quad (1.22)$$

Minimum RE share in a cell production

At the level of the cell, a minimum share of renewable production is imposed as well. Equation 1.23 states that the renewable production of the cell has to be greater or equal to a given

percentage of the total production and import from outside the system of the cell.

$$\left(\sum_i E_{PV,i,c} + \sum_j E_{WT,j,c} + E_{coal,c} + E_{nuc,c} + E_{dam,c} + E_{runriver,c} + E_{CCGT,imp,c} + E_{e,imp,c} \right) \cdot \mathbf{RE}_{share,c} \quad (1.23)$$

$$\leq \sum_i E_{PV,i,c} + \sum_j E_{WT,j,c} + E_{dam,c} + E_{runriver,c}$$

with

$$E_X = \sum_t P_X(t) \Delta t \quad (1.24)$$

Maximum import in the system

The system is able to import external electricity. However, the amount of electrical energy that can be imported is limited to a given percentage of the consumption:

$$\sum_{Cell\ c} E_{imp,c} \leq \mathbf{Imp}_{share} \sum_{Cell\ c} E_{cons,c} \quad (1.25)$$

Maximum import in a cell

The electrical energy that the cell can import from outside of the system is also limited to a given percentage of the consumption of the cell:

$$E_{imp,c} \leq \mathbf{Imp}_{share,c} \cdot E_{cons,c} \quad (1.26)$$

Power balance

In each cell and at each time t , the power production and consumption must be balanced (see Equation 1.27). Notice the convention used for the power sign: power produced in the cell and leaving the storage is considered positive while power stored is considered negative. A particular attention should be brought to the external import as well as the terms representing the inter-cells power flows $P_{e,exch,c_n,c}(t)$ (from other cells to the cell considered) and $P_{e,exch,c,c_n}(t)$ (from the cell considered to other cells), which are always considered positive. Practically, the production (left hand side term) can be greater than the consumption (right hand side term). The excess production, if coming from renewable sources, is considered as curtailment.

$$\forall t : \sum_i P_{PV,i,c}(t) + \sum_j P_{WT,j,c}(t) + P_{CCGT,c}(t) + P_{coal,c}(t) + P_{nuc,c}(t) \quad (1.27)$$

$$+ \sum_k (P_{b,in,k,c}(t) + P_{b,out,k,c}(t)) + P_{PHES,in,c}(t) + P_{PHES,out,c}(t) + P_{PtG,c}(t)$$

$$+ P_{dam,c}(t) + P_{runriver,c}(t) + P_{imp,c}(t) + \sum_n P_{e,exch,c_n,c}(t) - \sum_n P_{e,exch,c,c_n}(t)$$

$$\geq P_{cons,c}(t)$$

Storage balance

Batteries The evolution of the energy stored in the battery park k is represented by the recurrence Equation 1.28. One can see that the state of the storage at a given time depends on the storage at the previous time step minus the leakage, to which power is added and subtracted with a given efficiency. Equation 1.29 reports the cyclic condition set on the battery storage. It

means that the energy content of the batteries has to be the same at the beginning of the period than at the end.

$$\forall t > 0 : E_{b,k,c}(t) = E_{b,k,c}(t - \Delta t) (1 - \gamma_{k,c})^{\Delta t} - \left[\eta_{b,in,k,c} P_{b,in,k,c}(t - \Delta t) + \frac{P_{b,out,k,c}(t - \Delta t)}{\eta_{b,out,k,c}} \right] \Delta t \quad (1.28)$$

$$t = 0 : E_{b,k,c}(t) = E_{b,k,c}(t_{end}) (1 - \gamma_{k,c})^{\Delta t} - \left[\eta_{b,in,k,c} P_{b,in,k,c}(t_{end}) + \frac{P_{b,out,k,c}(t_{end})}{\eta_{b,out,k,c}} \right] \Delta t \quad (1.29)$$

PHES The storage balance of the PHES is similar to the one of the batteries, with the difference that no leakage is considered. As for the batteries, a cyclic condition is set between initial and final time step. The storage balance becomes:

$$\forall t > 0 : E_{PHES,c}(t) = E_{PHES,c}(t - \Delta t) - \left[\eta_{PHES,in,c} P_{PHES,in,c}(t - \Delta t) + \frac{P_{PHES,out,c}(t - \Delta t)}{\eta_{PHES,out,c}} \right] \Delta t \quad (1.30)$$

$$t = 0 : E_{PHES,c}(t) = E_{PHES,c}(t_{end}) - \left[\eta_{PHES,in,c} P_{PHES,in,c}(t_{end}) + \frac{P_{PHES,out,c}(t_{end})}{\eta_{PHES,out,c}} \right] \Delta t \quad (1.31)$$

Dam The Dam storage has the particularity that it is fed by a source which is not taken into account in the power balance. The feeding of the reservoir is the water local inflow. In equations 1.32 and 1.33, $P_{dam,in,c}$ corresponds to the power inlet from the local inflow in cell c and (negative) while $P_{dam,c}$ to the power generated by the dams (positive). Notice that no efficiency term appears in Equation 1.32. Indeed, the content of the storage is defined as the energy directly available for production, with losses through the turbines already taken into account. Again, a cyclic condition is set in Equation 1.33.

$$\forall t > 0 : E_{dam,c}(t) = E_{dam,c}(t - \Delta t) - \left[P_{dam,c}(t - \Delta t) + P_{dam,in,c}(t - \Delta t) \right] \Delta t \quad (1.32)$$

$$t = 0 : E_{dam,c}(t) = E_{dam,c}(t_{end}) - \left[P_{dam,c}(t_{end}) + P_{dam,in,c}(t_{end}) \right] \Delta t \quad (1.33)$$

Gas balance The gas storage has several inputs and outputs. The first input is the gas produced by the PtG unit. Then, the storage can also be filled by gas exchanged from another cell or with gas imported from outside the system. The storage can be emptied through the CCGT unit or by exchanging gas with another cell. This is expressed in Equation 1.34. Finally, a cyclic condition is set on the storage in Equation 1.35.

$$\begin{aligned}
\forall t > 0 : E_{gas,c}(t) = & E_{gas,c}(t - \Delta t) - \left[\eta_{PtG,c} \cdot P_{PtG,c}(t - \Delta t) - \frac{P_{ccgt,c}(t - \Delta t)}{\eta_{CCGT,c}} \right. \\
& + \sum_n P_{gas,exch,c_n,c}(t - \Delta t) - \sum_n P_{gas,exch,c,c_n}(t - \Delta t) \\
& \left. + P_{imp,gas,c} \right] \Delta t
\end{aligned} \tag{1.34}$$

$$\begin{aligned}
t = 0 : E_{gas,c}(t) = & E_{gas,c}(t_{end}) - \left[\eta_{PtG,c} \cdot P_{PtG,c}(t_{end}) - \frac{P_{ccgt,c}(t_{end})}{\eta_{CCGT,c}} \right. \\
& + \sum_n P_{gas,exch,c_n,c}(t_{end}) - \sum_n P_{gas,exch,c,c_n}(t_{end}) \\
& \left. + P_{imp,gas,c} \right] \Delta t
\end{aligned} \tag{1.35}$$

PtG minimal use

An extra constraint is set on the PtG. Since the energy cost of this type of storage is not well-known, it is interesting to set a minimum utilisation to be able to control the way this storage is used. This minimum utilisation constraint defines a minimum ratio between the energy which goes through the PtG unit and the maximum energy that could be absorbed at full load during the period T.

$$\sum_t P_{PtG,c}(t) \Delta t \geq \alpha_{PtG,c} P_{PtG,opt,max,c} \cdot T \tag{1.36}$$

1.4.3 Variable limits

This section details all the variable limits of the problem. The variable limits are the mathematical relations linking one variable with one or more scalar values.

Grids

Electricity The electric power exchanged between two cells is limited by the exchange capacity of the line connecting these cells. This limit can be different from one direction to the other. That is why two different limits are set (Equation 1.37 and 1.38). The power that a cell can import from outside the system is also limited by the exchange capacity of the importing lines (see Equation 1.39).

$$\forall t : P_{e,exch,c_n,c}(t) \leq P_{e,exch,max,c_n,c} \tag{1.37}$$

$$\forall t : P_{e,exch,c,c_n}(t) \leq P_{e,exch,max,c,c_n} \tag{1.38}$$

$$\forall t : P_{e,imp,c}(t) \leq P_{e,imp,max,c} \tag{1.39}$$

Gas The gas power exchanged between two cells is limited by the size of the pipelines connecting these two cells (Equations 1.40 and 1.41). As opposed to the electricity import, gas import is considered constant and has to be smaller than the maximal import capacity (Equation 1.42).

$$\forall t : P_{gas,exch,c_n,c}(t) \leq P_{gas,exch,max,c_n,c} \tag{1.40}$$

$$\forall t : P_{gas,exch,c,c_n}(t) \leq P_{gas,exch,max,c,c_n} \tag{1.41}$$

$$\forall t : P_{imp,gas,c} \leq P_{imp,gas,max,c} \tag{1.42}$$

Cells

Non-RE Production The non-RE production gathers the nuclear, CCGT and coal generations. The nuclear power is set as a base load corresponding to the installed power. The upper limit of the coal and of the CCGT corresponds to their already-installed capacities (Equations 1.43 and 1.44).

$$\forall t : 0 \leq P_{coal,c}(t) \leq P_{coal,max,c} \quad (1.43)$$

$$\forall t : 0 \leq P_{CCGT,c}(t) \leq P_{CCGT,max,c} \quad (1.44)$$

WT and PV parks The number of installed WTs and the surface of installed PV panels are bounded by two factors. The lower limits correspond to the already-installed capacity and the upper limits to the technical potential of the cell, both defined as a number of WT and a surface of PV panels.

$$area_{PV,min,i,c} \leq area_{PV,i,c} \leq area_{PV,max,i,c} \quad (1.45)$$

$$n_{WT,min,j,c} \leq n_{WT,j,c} \leq n_{WT,max,j,c} \quad (1.46)$$

Dam The dam generation is driven by three limits. The first one binds the reservoir (Equation 1.47) to a minimal and maximal energy content. The second one concerns the water inflow. The water power entering the reservoir is equal to the local inflow or smaller in case of water spillage (Equation 1.48). Notice the sign of $P_{dam,in,c}(t)$ which has been defined negative. The third limit constraints the power generation of the dams, which has to range from 0 to the installed power capacity (Equation 1.49).

$$\forall t : E_{dam,min,c} \leq E_{dam,c}(t) \leq E_{dam,max,c} \quad (1.47)$$

$$\forall t : -inflow_{dam,c}(t) \leq P_{dam,in,c}(t) \leq 0 \quad (1.48)$$

$$\forall t : 0 \leq P_{dam,c}(t) \leq P_{dam,max,c} \quad (1.49)$$

Run-of-the-river As for the dams, run-of-the-river production depends on the local inflow. However, no reservoir is available. It is then necessary to inject all the water through the turbines or to spill a certain quantity of water. This is stated in Equation 1.50. Similar to the other means of production, the power generation range from 0 to the installed capacity (Equation 1.51).

$$\forall t : 0 \leq P_{runriver,c}(t) \leq inflow_{runriver,c}(t) \quad (1.50)$$

$$\forall t : 0 \leq P_{runriver,c}(t) \leq P_{runriver,inst,c} \quad (1.51)$$

Batteries Equation 1.52 states that the optimal installed capacity has to lie between the minimal and maximal storage capacity (fixed as inputs). The second and third relations (Equations 1.53 and 1.54) state the maximum power input and output of the batteries respectively. These upper bounds are directly linked to the installed storage capacity by the charge and discharge rate. Finally, Equation 1.55 states the limit of the energy content of the batteries. The depth of discharge (*DoD*) translates the fact that the battery cannot be discharged entirely. Notice that the three last relations are not variable limits but constraints since two variables are involved.

$$E_{b,min,k,c} \leq E_{b,max,opt,k,c} \leq E_{b,max,k,c} \quad (1.52)$$

$$\forall t : -E_{b,max,opt,k,c} \alpha_{b,in,k,c} \leq P_{b,in,k,c}(t) \leq 0 \quad (1.53)$$

$$\forall t : 0 \leq P_{i,out}(t) \leq E_{b,max,opt,k,c} \alpha_{out} \quad (1.54)$$

$$\forall t : E_{b,max,opt,k,c}(1 - D_o D_{b,k,c}) \leq E_{b,k,c}(t) \leq E_{b,max,opt,k,c} \quad (1.55)$$

PHES PHES is limited by its reservoir and its installed generation and pumping capacities. The reservoir is limited by the reservoir size and minimal water content (Equation 1.56) and the generation and pumping power must be smaller than the corresponding installed capacity (Equation 1.57 and 1.58).

$$\forall t : E_{PHES,min,c} \leq E_{PHES,c}(t) \leq E_{PHES,max,c} \quad (1.56)$$

$$\forall t : 0 \leq P_{PHES,out,c}(t) \leq P_{PHES,inst,out,c} \quad (1.57)$$

$$\forall t : -P_{PHES,inst,in,c} \leq P_{PHES,in,c}(t) \leq 0 \quad (1.58)$$

PtG As for the batteries, the PtG installed capacity is optimised and should lie between the maximal and minimal set capacities (Equation 1.59). The input power (defined negative) has to range from 0 to the optimised installed capacity (Equation 1.60).

$$P_{PtG,inst,min,c} \leq P_{PtG,inst,opt,c} \leq P_{PtG,inst,max,c} \quad (1.59)$$

$$\forall t : -P_{PtG,inst,opt,c} \leq P_{PtG,c}(t) \leq 0 \quad (1.60)$$

Gas storage Again, the gas storage reservoir is optimised and should lie between the maximal and minimal set capacities (Equation 1.61) and the content of the reservoir must lie between its lower filling limit and the optimal installed reservoir (Equation 1.62).

$$E_{gas,min,c} \leq E_{gas,max,opt,c} \leq E_{gas,max,c} \quad (1.61)$$

$$E_{gas,min,c} \leq E_{gas,c}(t) \leq E_{gas,max,opt,c} \quad (1.62)$$

$$(1.63)$$

Chapter 2

Validation

The goal of this chapter is to validate the new tool developed by applying it to the case of the Belgium transition studied by G. Limpens in [71] and to compare the results obtained by the new tool and by the tool used in the aforementioned study. In the following lines, the "*MATLAB tool*" refers to the tool developed in [71] and the "*Python tool*" to the new tool elaborated.

2.1 Study cases

In order to study the Belgium transition, the country is divided in two cells: the inland territory and the offshore WT parks. The two cells are interconnected by a transmission line. As stated in Section 1.1, the means of production used in this model are: WTs, PV panels, CCGT and nuclear power plants. The storage systems are: batteries, PHES, and gas storage (PtG with gas storage).

In [71], four scenarios of the transition of Belgium from today towards a 100% RE electricity system are presented. The scenarios cover a one-year period and are studied with a time step of one hour. In each scenario, the electricity imported from outside the system over the period studied is fixed at maximum 10% of the consumption. The production supplies therefore 90% of the consumption. The actual Belgian electricity generation relies mainly on nuclear (50%), gas (30%) and renewable (20%) [49]. This mix defines the first study case. The second scenario with 10% nuclear, 50% RE and 40% gas can depict Belgium in 15-20 years. The third scenario presents a production mix of 0% nuclear, 80% RE and 20% gas, which may illustrate Belgium in 30 years. The last scenario is a production 100% renewable. Those four scenarios are used to compare the two tools. The MATLAB tool has been provided by G. Limpens and all the results presented hereunder were recomputed.

The input values and parameters are presented in Appendix B. It was not possible to retrieve all the same inputs than the ones used in the aforementioned study. Small differences appear thus between the results of the MATLAB tool presented in Table 2.1 and 2.2 and the ones from [71].

2.2 Results and discussion

Table 2.1 and 2.2 present the results for the RE and storage assets and curtailment of the tool developed by G. Limpens in [71] and of the new tool developed for the Western Europe study for the four scenarios. It can be underlined that the two tools give the same outputs for the study of Belgium. Other key indicators as the variation of the energy stored in the different storage systems are identical for both tools with a variation of less than 1%.

In conclusion, based on these results, one can guarantee the correct functioning of the program developed.

Table 2.1: Results for RE assets and curtailment.

	Scenario			Tool	WT [5MW_{eq}]		PV		Curt. [%]
	RE	Nuc	Gas		On.	Off.	[km^2]	[GWp]	
1.	20%	50%	30%	MATLAB	1190	151	40.3	4.03	0.98
				Python	1190	151	40.3	4.03	0.98
2.	50%	10%	40%	MATLAB	2007	754	130.1	13.01	4.8
				Python	2007	754	130.1	13.01	4.8
3.	80%	0%	20%	MATLAB	2007	754	435.7	43.57	6.51
				Python	2007	754	435.6	43.56	6.51
4.	100%	0%	0%	MATLAB	2007	754	712.6	71.26	19.5
				Python	2007	754	712.7	71.27	19.5

Table 2.2: Results for storage assets.

Scenario	Tool	Battery [GWh]	PtG [MW]	Gas Storage [GWh]
1.	MATLAB	2.6	0	662.3
	Python	2.5	0	662.1
2.	MATLAB	9.5	0	1 330.6
	Python	9.6	0	1 331.0
3.	MATLAB	114.7	1000	4 378.7
	Python	114.7	1000	4 376.7
4.	MATLAB	241.1	1000	2 583.4
	Python	241.3	1000	2 584.1

Chapter 3

Western Europe model

In this chapter, the implementation of the Western Europe electricity system as well as the different inputs are detailed. First, the objectives are introduced. Second, the definition of the cells is presented. Then, the implementation of the cells and their input data is explained. Finally, the limits and hypotheses of the model are analysed. The model is based on a period of one year and allows a minimum time step of one hour.

3.1 Objectives

Western Europe electricity system is modelled in order to analyse transition or 100% RE scenarios of the upcoming decades at a macro spatial scale. The aim is thus to represent as faithfully as possible the actual Western Europe electricity system which can then be applied to the desired scenario thanks to the input parameters presented in Section 1 (e.g. RE share of the system or of the cell, import share, etc.).

3.2 Definition of the cells

The first step to model Western Europe system is to define the different cells of the system. As explained in Section 1.2, the division of the cells defines the spatial resolution of the system and impacts directly the computational time. A trade-off has then to be found. The goal of this study being to analyse the Western Europe electricity system on a macro scale (at the scale of countries or group of countries), six cells are defined. These cells are:

- Scandinavia: Norway, Sweden, Denmark
- British Isles: United Kingdom, Ireland
- Germany & Benelux: Germany, Belgium, Netherlands, Luxembourg
- France
- Italy and Alpine states: Italy, Switzerland, Austria
- Iberian Peninsula: Spain, Portugal

The same division of Western Europe is found in other studies [15]. The cells are presented in Figure 3.1. These choices are based on multiple considerations: size of the cells, availability of data, policies, energy mixes, interconnections, geography and climate, which are explained in more details here under.

First, the cells tend to have an area, population, electricity consumption and electricity production of the same order of magnitude. Those parameters are presented in Table 3.1. One notices though that the population, consumption and production of Germany & Benelux is noticeably higher than for the other cells.

Second, the division is based on country borders. Indeed, each country has its own policies concerning electricity production. For example, Germany replaced the major part of its nuclear

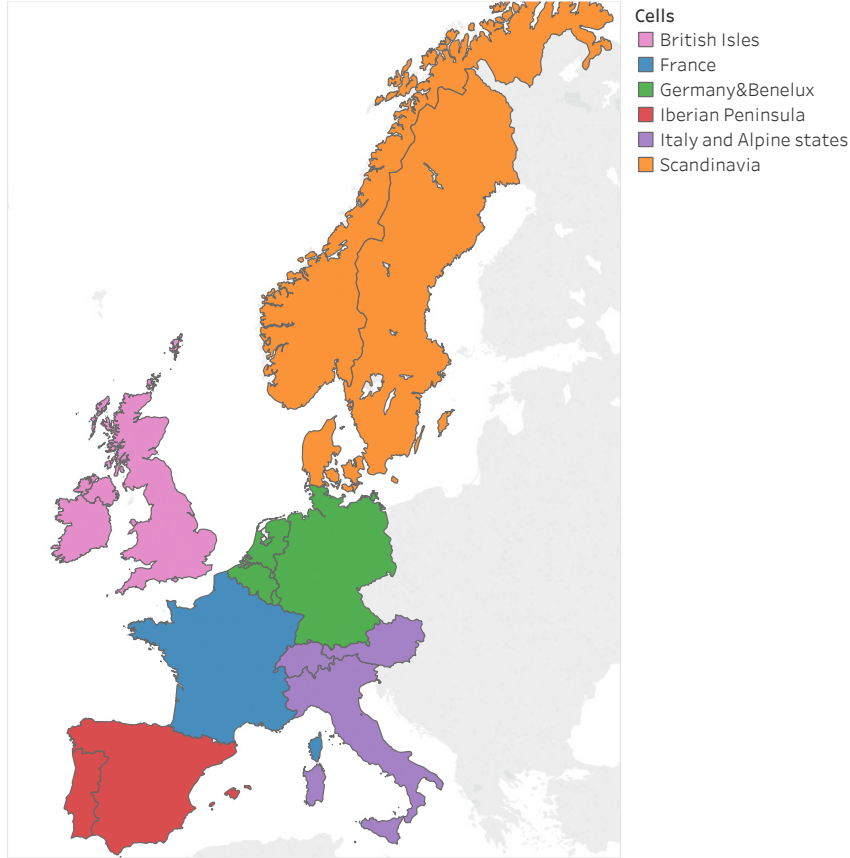

Figure 3.1: Definition of the cells for the Western Europe model.

Table 3.1: Area, population and annual electricity consumption and production of the cells [48–62].

Cell	Area [km ²]	Population [millions]	Annual elec. consumption [TWh]	Annual elec. production [TWh]
Scandinavia	876 000	21	303	334
British Isles	315 000	70	370	366
Germany & Benelux	432 000	112	724	840
France	644 000	69	479	550
Italy and Alpine states	427 000	78	452	410
Iberian Peninsula	598 000	57	302	328

electricity production by renewables and biofuels and strives to be out of nuclear by 2022 [7] while France still has a strong nuclear park and is deeply involved in nuclear research [17]. Each country is thus characterised by a distinct energy mix and particular goals. Moreover, most of the data concerning electricity production and consumption as well as RE potentials are given per country. It would then be inconvenient to create cells not respecting the political borders.

Third, as said in Section 1.2, a cell has to be characterised by a good electricity transmission grid, so that the copper plate hypothesis can be reasonably made. This hypothesis is strong since even at the scale of a country it is sometimes not entirely true. Germany, for example, suffers from congestion between the north and the south in case of high winds [6]. Exchange capacity between countries is often even more limited as it can be observed in [30]. The division tends to gather countries with reasonably good connections and to separate countries with a weak interconnection. The analysis of the European transmission system has been led using ENTSO-E Transmission System Map [30] to locate existing connections between countries and the Net

Transfer Capacity archives of ENTSOE [28] to determine inter-countries exchange capacities.

A fourth criterion to gather or separate countries is the weather and the geography. In order to limit the number of PV and WT parks implemented per cell, the cells have to cover an area with similar wind and irradiance profiles. The wind and irradiance profiles of Western Europe are presented in Figures 3.2 and 3.3 respectively. Figure 3.2 represents the mean wind speed and mean wind power at 50 m above ground level. From this figure, it can be stressed that the north of Europe (Scandinavia and British Isles) presents a good wind potential. This potential lowers from north to south and is very low for the north of Italy & Alpine states. It is also noticeable that the potential is higher close to the coast. In Figure 3.3, the annual full load hours (number of hours the generators would have to run at full capacity to produce the electricity it actually generated over the year) of optimally inclined PV modules are represented. It can be underlined that the annual full load hours decrease from north to south. It is thus important to have a size of cell which is not too wide in latitude. Moreover, the geography plays a role in the energy mix. For example, mountainous countries have a higher share of hydroelectric production and storage.

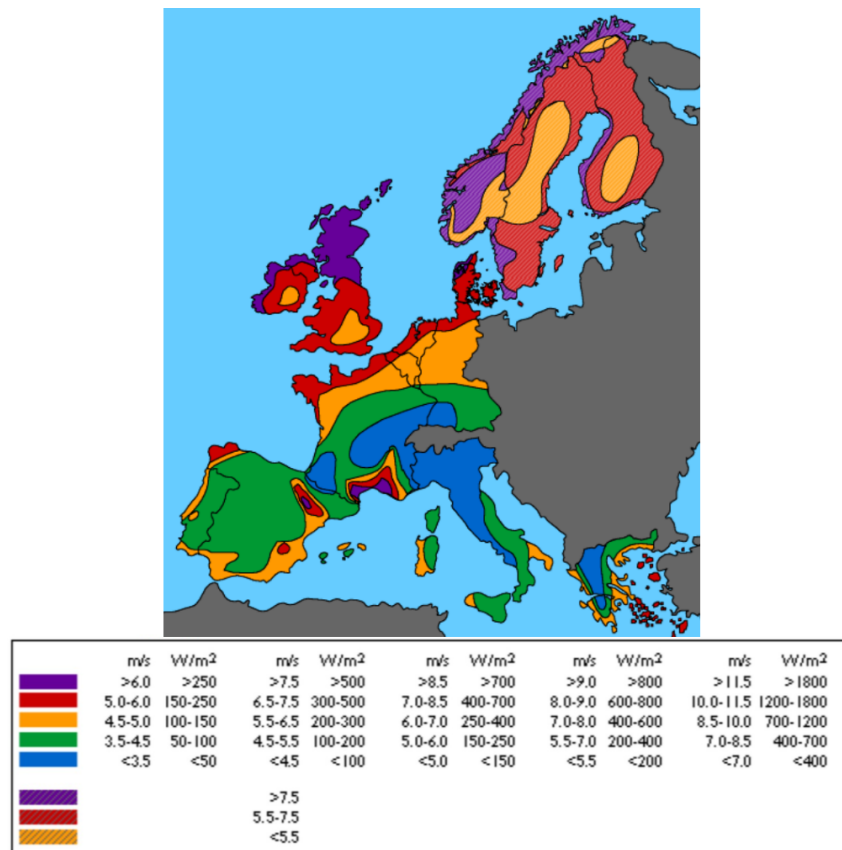

Figure 3.2: Mean wind speed and mean wind power at 50 (45) m above ground level for 5 different topographical conditions [89].

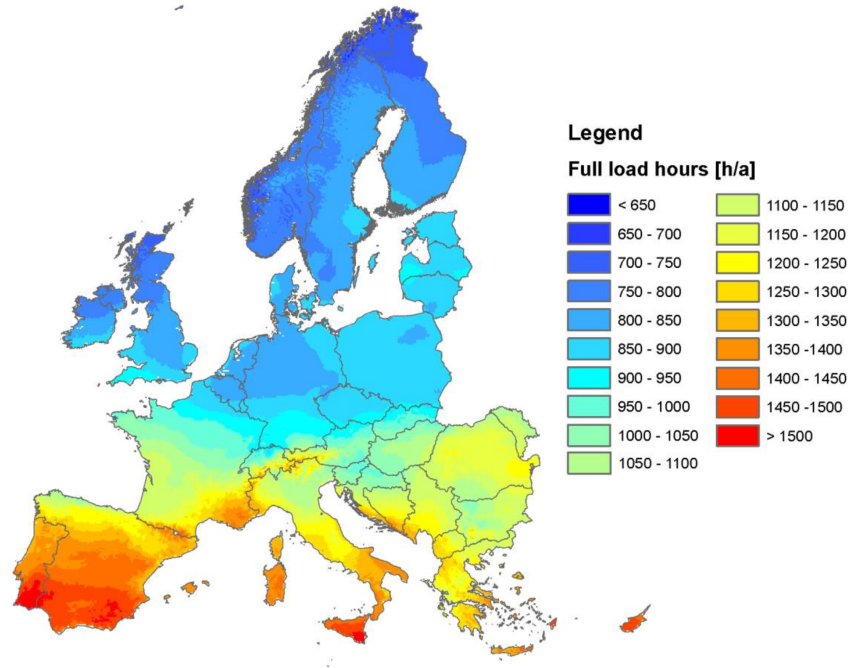

Figure 3.3: Annual full load hours of optimally inclined PV modules [45].

The main characteristics of the cells and the specific reasons of the division are presented hereafter.

Scandinavia Scandinavia is characterised by good interconnections between Norway, Denmark and Sweden. Moreover, it is a synchronous grid independent in frequency from the continent (apart from the continental part of Denmark). The irradiance is rather uniform through these countries and relatively low due to their high latitude. Furthermore, Norway and Sweden have a particular production mix in which hydroelectric power provides a large part of the energy, as it can be seen in 3.4. Scandinavia is the cell with the highest RE share (76%). Moreover, Scandinavia is the least-densely populated cell with only 23 inhabitants per square kilometre but the one with the highest annual electricity consumption per capita with 14 286 kWh per inhabitant which represents approximately 2.5 times the one of the other cells.

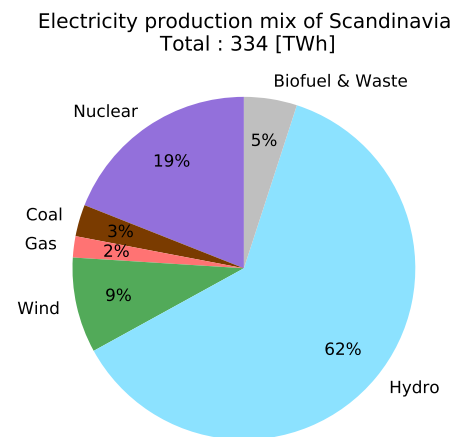

Figure 3.4: Electricity production mix of Scandinavia of 2017. Adapted from [50, 57, 60].

British Isles British Isles gathers United Kingdom and Ireland. Similar to Scandinavia, it is not synchronised with the continental grid. The connection between these two distinct grids is of only 2 GW according to [28]. Ireland and Great Britain are connected by a total exchange capacity of 1 GW [79]. Irradiance profile is rather homogeneous and, looking at the wind profile, one can see that the cell presents a good potential onshore and offshore. One can notice from Figure 3.5 that British Isles presents a high share of gas production (44%) compared to the other cells. This cell presents the smallest area but is also the second most-densely populated after Germany & Benelux.

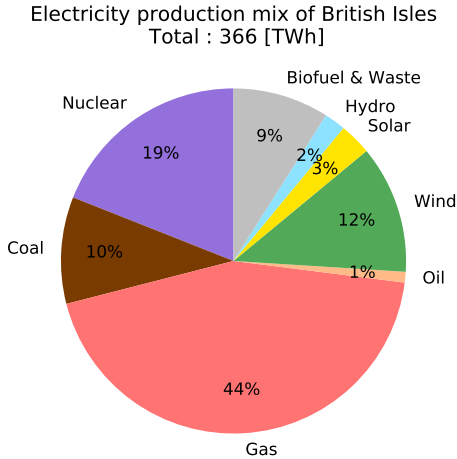

Figure 3.5: Electricity production mix of British Isles of 2017. Adapted from [53, 62].

Germany & Benelux Germany & Benelux gathers Germany, Belgium, Netherlands and Luxembourg which present good interconnections between each other. The irradiance of Benelux and of north of Germany are similar. However, south of Germany has a higher PV potential but still low compared to the south of Europe. These countries also share a high wind potential on the northern coast. Coal plays an important role in the German mix, leading to the important coal share in the mix of the cell as it can be seen in Figure 3.6. Germany & Benelux is the cell with the highest population but also the most-densely populated with 259 inhabitants per square kilometre. This cell presents as well the most important electricity consumption and production.

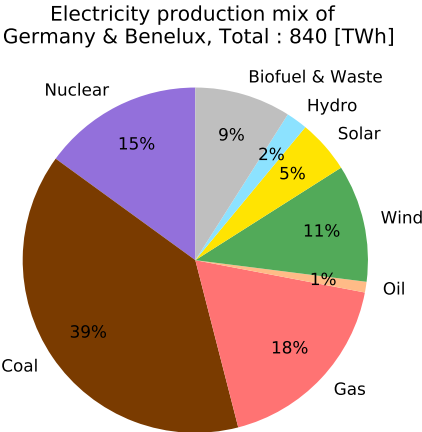

Figure 3.6: Electricity production mix of Germany & Benelux of 2017. Adapted from [49, 52, 55, 56].

France France is the only cell gathering only one country. It is located at the centre of the Western Europe system and connected to all the cells except Scandinavia. France has a strong irradiance deviation between the north and the south. Similarly, wind is strongly dependent on the proximity of the sea. France has a particular energy mix with the highest nuclear share among the cells under study.

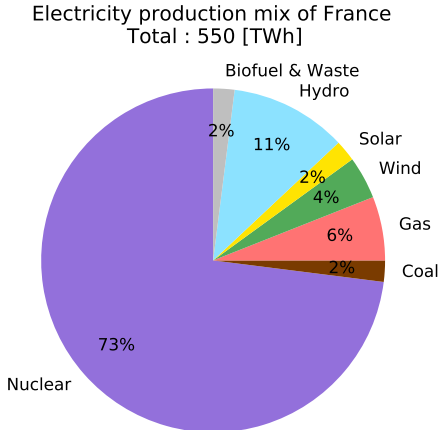

Figure 3.7: Electricity production mix of France of 2017. Adapted from [51].

Italy and Alpine states This cell gathers Italy, Austria and Switzerland. The main reasons why these countries are grouped is due to their geographical similarities. Indeed, Switzerland, Austria and north of Italy are highly mountainous areas. This geography has been used to install an important hydroelectric capacity which represents 28% of the production. These countries are characterised by a relatively low wind potential. Strong differences can be observed between the north and the south concerning PV potential. In fact, Sicily experiences much stronger irradiance than the Alpine states. Italy and Alpine states presents the second highest RE share, with 49%.

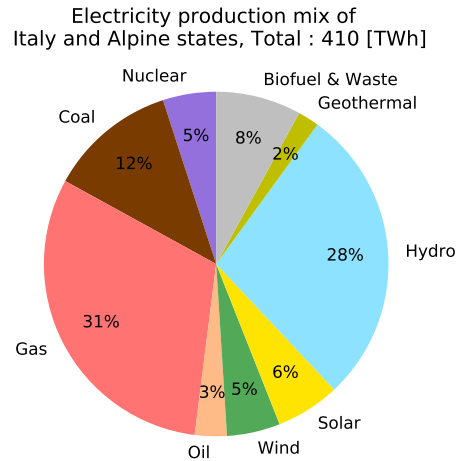

Figure 3.8: Electricity production mix of Italy and Alpine states of 2017. Adapted from [48, 54, 61].

Iberian Peninsula Iberian Peninsula gathers Spain and Portugal. This cell presents a relatively homogeneous and high irradiance. Moreover, the onshore wind potential is similar throughout the cell. Looking at Figure 3.9, one can notice that Iberian Peninsula presents a RE share of 41% with a high share of wind production (19%).

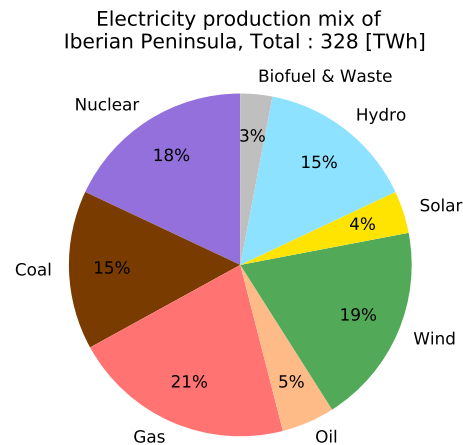

Figure 3.9: Electricity production mix of Iberian Peninsula of 2017. Adapted from [58, 59].

3.3 Implementation of the cells and input data

In this section, the implementation of the consumers, producers and storage systems of the cells is detailed. The input parameters characterising the cells and the global system as well as the different input profiles are introduced. The methods used to process the inputs are explained and discussed. All the input profiles cover a period of one year with a time step of one hour.

3.3.1 Consumption

Hourly electricity consumption profiles are retrieved from the ENTSOE database [29]. For each cell, the profile of each country of the cell are summed to represent the total consumption for the year 2017. This year has been chosen due to the availability of the data of the ENTSOE website.

3.3.2 Actual production capacities

The data of the electricity production capacities are taken from ENTSOE Transparency platform [31]. The generation systems are classified in twenty-seven production types. For each country, the installed generation capacity of each production type is collected. Then, each corresponding type is summed for each cell to have the generation capacity per type of the cell. This can be seen in Table C.1. Those production types are much more detailed than the one implemented in our model which are: Nuclear, CCGT, Coal, WT, PV panel, Dam and Run-of-the-river. The production types are thus gathered in the seven different production assets implemented in the model. Every by-product of coal, such as lignite, hard-coal and coal-derived-gas are compiled in the coal type. The other fossil fuel generation types, along with the biomass, the biogas, the wastes, the "other non-renewable" as well as the uncategorised type "Other" are gathered in the CCGT. Solar renewable production has two different sources: photovoltaic and thermal. These two types are gathered under the PV installed capacity. Finally, the "Other renewables" together with marine and geothermal generation capacity are neglected.

Further research has been led to define the already-installed capacity of WT and PV in the different countries due to some incoherent values in [31]. For PV, ENTSOE values have been compared with [82], [23] and [78]. For WT, ENTSOE values have been compared with [37], [8], [83], [81] and [25]. When values of ENTSOE were significantly different from the one specified by a given country report, the last one was kept. The already-installed WT and PV capacities represent the lower limit of these RE assets and are presented in Table 3.4.

The actual production capacities of each cell are resumed in Table C.2.

3.3.3 Wind turbines

Two WT parks are implemented in each cell: one onshore and one offshore. Each park is defined by its own load factor and wind profile. They all have the same WT model but the energy cost varies between onshore and offshore due to different installation, maintenance and dismantling energy costs [24].

The wind profiles of the two parks of a cell are defined from the same initial wind speed time series. The wind speed is then scaled for each park to reach the load factor wanted, defining thus two distinct power production profiles.

In the following subsection, the model of the WT is presented. Then, the methods used to determine the load factor, the technical potential and the wind profile of each park are detailed.

Model

The WT model chosen for offshore and onshore parks is the 5 MW Reference Wind Turbine for Offshore System Development presented in [64] whose characteristics used in the model are presented in Table 3.2. The same WT model is used in [71] and [24].

Characteristic	Value
Rating [MW]	5
Cut-In wind speed [m/s]	3
Rated wind speed [m/s]	11.4
Cut-Out wind speed [m/s]	25
Lifetime [years]	25
Energy cost onshore [MWh/5MW _{eq}]	18 713
Energy cost offshore [MWh/5MW _{eq}]	39 818

Table 3.2: WT model characteristics.

The energy cost of the WT depends on its location, as stated in [24]. It costs energetically more to install, maintain and dismantle offshore than onshore WTs. For the onshore installations, the energetic cost varies with the project (e.g. installation in the mountains, in a field, etc.) but the variations are small. For the offshore installations, the cost strongly depends on the distance to the shore and the water depth, as detailed in [24]. Average values of the energy cost were taken from [24] and are presented in Table 3.2. These values are identical to those introduced in [71]. The energetic cost of the offshore WTs corresponds to the one of a WT located at 25 kilometres from the shore with a water depth of 30 meters.

Load Factor

Looking at the literature [35, 36], the average load factor expected for Western Europe is around 20-25% for onshore and 35-45% for offshore. To compute the load factors of the cell, the annual offshore and onshore load factors of each country is computed using the actual offshore and onshore installed capacity and production from the ENTSOE website [29]:

$$LF_{year} = \frac{\text{annual production [Wh]}}{\text{capacity [W]} \cdot 8760[h]}$$

The global load factor of the cell is then computed via a weighting of the load factor of each country by its technical potential. $LF_{j,c}$ being the load factor of the WT park j (onshore or offshore) in cell c , it gives:

$$LF_{j,c} = \frac{\sum_{country} LF_{country,j} \cdot n_{WT,max,j,country}}{n_{WT,max,j,c}} \quad (3.1)$$

where, $country$ is one of the country in c , $LF_{country,j}$ is the load factor (onshore or offshore) of a given country, $n_{WT,max,j,country}$ is the technical potential (onshore or offshore) of the country and $n_{WT,max,j,c}$ is the total technical potential (onshore or offshore) of the cell.

Concerning the countries for which it was not possible to compute the load factor via the production and capacity from ENTSOE (missing value or no installed capacity) the load factors were based on the results from [47] and [24].

Table 3.3: WTs load factor and gross EROI.

Cell	WT onshore load factor	WT onshore EROI	WT offshore load factor	WT offshore EROI
Scandinavia	26.7%	15.6	46.8%	12.8
British Isles	25.1%	14.6	37.0%	10.2
Germany & Benelux	20.0%	11.7	40.5%	11.1
France	20.2%	11.8	43.0%	11.8
Italy and Alpine States	22.0%	12.8	33.1%	9.1
Iberian Peninsula	24.2%	14.3	38.4%	10.6

Table 3.3 resumes the load factor and gross EROI of the onshore and offshore WT park of each cell. EROI values are obtained using the load factors presented in Table 3.3 and the energy cost defined in Table 3.2. It is interesting to compare these EROIs with the wind map, Figure 3.2. Regarding the EROI of the onshore WTs, the highest are found in the northern cells, coinciding with what is observed on the map. The value obtained for Iberian Peninsula is surprisingly high compared to the expected value. Since load factor data come from actual production values, this would mean that Iberian onshore parks are built in specific locations with strong winds. It is to expect that this value could decrease with high WT density, forcing to build in less suitable

locations. Concerning the offshore WTs, it can again be pointed that EROI decreases from north to south. However, British Isles offshore load factor is actually rather low, estimated at 33% by ENSTOE [29] and at 37% by IEA [4]. This value can be expected to increase in the coming years, with the implementation of more efficient parks replacing the older ones [34].

Technical potential

In order to compute the onshore and offshore WT technical potential, the repartition of the available areas into land use categories with a respective suitability factor is used and taken from [24]. The complete data are presented in Table C.3, C.4, C.5 and C.6. For offshore wind, selected land categories are the one with a water depth smaller than 200 m. Nowadays, offshore wind turbines rely on fixed foundations and can only reach approximately 50 m water depth [9]. To unlock deeper water area, floating structures will be needed. These structures are still under study and not ready yet to be commercialised. Moreover, the values given in [24] can suffer from certain inaccuracies. Indeed, for example, sea routes have not been considered, leading to a possible overestimation of the potential. In this study, offshore available areas are then divided by two in order to reduce the needs of floating structures in the energy mix and to avoid an overestimate of the technical potential.

The technical potential of park j in cell c ($n_{WT,max,j,c}$) is computed as the sum of all the available area of a given land category ℓ included in the park j of c ($A_{\ell,j,c}$) weighted by the suitability factor of this land category ($\kappa_{WT,\ell,c}$) multiplied by the capacity density of the park ($\rho_{P_{WT,j,c}}$) and divided by the nominal power of a WT (P_n):

$$n_{WT,max,j,c} = \frac{\rho_{P_{WT,j,c}} \cdot \sum_{\ell} A_{\ell,j,c} \cdot \kappa_{WT,\ell,c}}{P_n} \quad (3.2)$$

The density $\rho_{P_{WT,j,c}}$ is set to 4 MW/km² for both onshore and offshore parks based on [46]. The results for the WT assets are presented in a number of 5 MW_{eq} WT. If the corresponding area wants to be computed, one has thus to divide this number by 0.8/km².

Table 3.4 resumes the lower and upper limits of WTs technical potential.

Table 3.4: RE limits in number of 5MW_{eq} WTs and km² of PV panels. The lower limit corresponds to the already-installed capacity and the upper limit to the technical potential.

Cell	WT onshore [5MW _{eq}]		WT Offshore [5MW _{eq}]		PV [km ²]	
	Lower	Upper	Lower	Upper	Lower	Upper
Scandinavia	2 413	234 654	294	72 936	7	5 590
British Isles	2 956	159 236	1 277	111 183	127	4 461
Germany & Benelux	11 085	137 912	1 441	23 839	481	3 750
France	2 709	220 877	2	24 579	77	6 532
Italy and Alpine states	2 436	144 689	0	10 404	213	3 956
Iberian Peninsula	558	227 230	1	7 970	72	6 565

Wind profile

As said earlier, one wind profile is used for each cell and the wind profile of each park is scaled to obtain the load factor defined for the park.

The input wind profile are hourly values of the wind speed at 10 m of a typical year based on twenty years of a representative city of the cell. These data are from the tool Meteonorm [73].

In order to choose the representative wind profile of each cell, numerous wind time series from different cities are collected as shown in Figure 3.10. Each wind data is then normalised

such that:

$$\hat{w}_{i,c}(t) = \frac{w_{i,c}(t)}{\max(w_{i,c}(t))} \quad (3.3)$$

with $w_{i,c}(t)$ a given wind time series in a given cell c and $\hat{w}_{i,c}(t)$ the corresponding normalised time series. Afterwards, the mean wind time series is computed for each cell:

$$\bar{w}_c(t) = \frac{1}{N_c} \sum_{i=1}^{N_c} \hat{w}_{i,c}(t) \quad (3.4)$$

with N_c the number of different time series in a given cell. For each cell, the mean square error between each time series and the mean time series is computed as:

$$MSE_{i,c} = \frac{1}{T} \sum_t (\hat{w}_{i,c}(t) - \bar{w}_c(t))^2 \quad (3.5)$$

Finally, the wind profile $w_{i,c}(t)$ with the smallest mean square error is chosen as the representative wind profile of the cell. The chosen representative locations can be seen in Figure 3.11. It is important to notice that only the profile of the wind is of interest. Since the wind speed is scaled to reach the load factor of the cell, the location of the representative profile does not have any influence on the annual energy production.

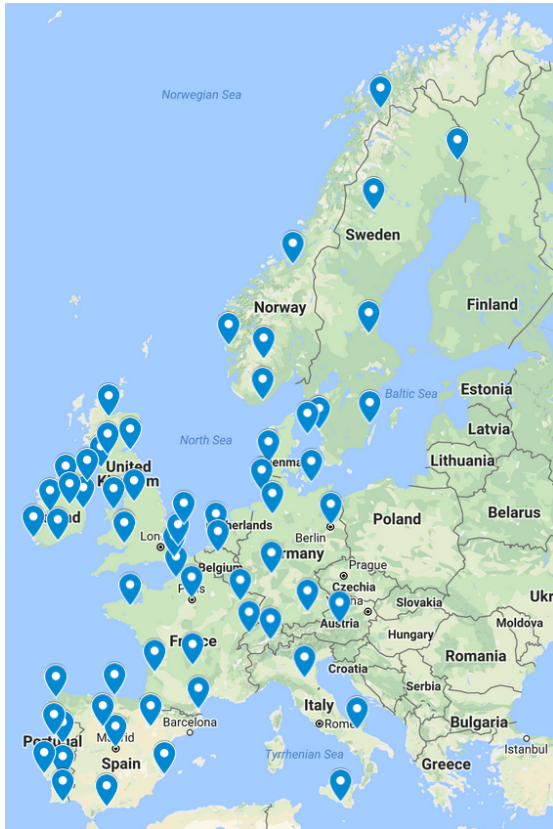

Figure 3.10: Location from which wind time series are collected.



Figure 3.11: Location of the representative wind time series of the cells.

3.3.4 PV panels

One PV panel park is implemented in each cell. Each park is characterised by an irradiance profile and a load factor. As for the WTs, the irradiance profile is scaled to reach the load factor of the cell. All the PV park have the same PV panel model.

In the following subsection, the model of the PV panels is presented. Then, the methods used to determine the load factor, the technical potential and the irradiance profile of each park are detailed.

Model

The PV panel model is similar to the one used in [71]. Its characteristics are presented in Table 3.5. The energy investment cost is assumed equal for all the PV installations.

Table 3.5: PV panel model characteristics.

Characteristic	Value
η [%]	10
Lifetime [years]	30
Energy cost [kWh/m ²]	428

Load Factor

The average annual load factor for PV production is based on the database Renewable Ninja [47]. This database provides hourly load factors computed from 1996 to 2016 based on meteorological data for each country. It results from the study in [86]. The annual load factor used for each country corresponds to the mean load factor over the last twenty years. The load factor of a given cell is then computed similarly as for the WT, via a weighting of the load factor of each country with respect to their technical potential.

These load factors can be seen in Table 3.6 together with gross EROIs, which are computed using the load factors and the energy cost of the PV panels. These values can be compared with the PV potential map in Figure 3.3. It can be observed that EROI increases from north to south, as expected.

Table 3.6: Load factors and gross EROIs of the PV panels.

Cell	PV load factor	PV EROI
Scandinavia	9.9%	6.1
British Isles	10.8%	6.6
Germany & Benelux	12.4%	7.6
France	14.0%	8.6
Italy and Alpine states	15.3%	9.4
Iberian Peninsula	16.7%	10.3

Technical potential

As for the WTs, the technical potential is computed using the repartition of the available areas into land use categories and the suitability factor of each category from the data used in [24]. Those data are presented in Table C.3, C.4, C.5 and C.6. A factor of net PV surface in comparison with the necessary surface of the installation is set to take into account the space between the panels and is equal to 5. That is to say that on a surface of 1 km², 0.2 km² of PV panels may be installed. The technical surface of PV panels is given by:

$$S_{PV,max,c} = \frac{\sum_{\ell} A_{\ell,c} \cdot \kappa_{PV,\ell,c}}{\alpha_{PV,c}} \quad (3.6)$$

where $S_{PV,max,c}$ is the PV technical potential of the park in cell c expressed as a surface of PV panels, $A_{\ell,c}$ is the available area of a given land category ℓ , $\kappa_{PV,\ell,c}$ is the PV suitability factor of this land category and $\alpha_{PV,c}$ is the factor of net PV surface in comparison with the necessary surface of the installation.

Table 3.4 resumes the upper and lower limits of PV panels technical potential.

Irradiance profile

The input irradiance profiles are hourly values of the Global Horizontal Irradiance (GHI) of a typical year based over twenty years of measurements of a representative city of the cell. These data are from the tool Meteonorm [73]. As said earlier, these irradiance profiles are scaled to reach the load factor of the cell.

In order to choose the representative GHI profile, numerous cities are cleverly chosen inside the cell (see Figure 3.12). As for wind, the one with the normalised profile presenting the smallest squared error with respect to the average of all the normalised profiles is kept. The chosen representative locations can be seen in Figure 3.13. Similar to wind data processing, it has to be noticed that the location of the representative profile will not influence the PV annual production in a cell. Indeed, the irradiance profile is scaled to reach the load factor of the cell.



Figure 3.12: Location from which irradiance time series are collected.

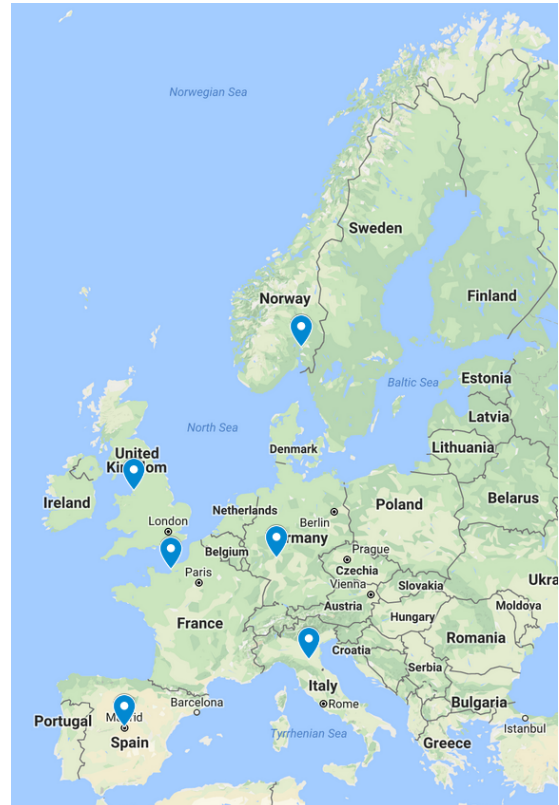

Figure 3.13: Location of the representative irradiance time series of the cells.

3.3.5 Hydroelectric power plants

As already mentioned, there are two different hydroelectric means of production: dams and run-of-the-river power stations. Dams represent all the hydroelectric power stations with reservoir, while run-of-the-river power stations gather the ones without reservoir. The profile of the local inflow of both system is needed. First, the annual production is computed. Then, the profile of the local inflow is determined. The water inlet of the model corresponds to the local inflow profile

scaled by the annual production. No acceptable data have been found to define the capacity of the reservoir of the dams. Thus, an educated guess value of the reservoir capacity is taken at 50% of the total annual production.

Annual production

Annual hydroelectric productions are fetched from ENTSO-E power statistics [29] and can be found in Table 3.7. ENTSOE website states three different types of hydroelectric production: "Pure storage", "Run-of-the-river and pondage", and "Mixed pumped storage". It must be noticed that the "Pure storage" does not correspond to PHES but to a classic dam without the possibility of pumping. The Dam category defined here gathers the production of the "Pure storage" type and the renewable production part of the "Mixed pumped storage" type. This corresponds to the production of the dams without PHES and the production coming from the water inlet of the dams coupled with a PHES respectively. The Run-of-the-river category gathers only the "Run-of-the-river and pondage".

Table 3.7: Annual hydroelectric production in Western Europe.

Cell	Dam [TWh]	Run-of-the-river [TWh]
Scandinavia	194.11	0.02
British Isles	2.94	5.26
Germany & Benelux	0.63	19.23
France	21.94	26.65
Italy and Alpine States	38.34	68.86
Iberian Peninsula	14.79	9.11

Local inflow

The production of dams and run-of-the-river power stations is linked to their water inlet, i.e. the flow rate of the river over which the plant is installed. To model this inflow, data from the Global Runoff Data Centre (GRDC) have been retrieved, giving for each river in each European country the monthly mean discharge over the year [18]. These river data are summed for a given cell to obtain a flow rate profile in the cell. The normalised profiles can be seen in Figure 3.14. It is interesting to notice two types of profile. The first one could be called "rainy winter" profile. This is what can be observed in Germany & Benelux, France, Iberian Peninsula and British Isles. Indeed, high river discharge are observed between October and April. The second profile could be named "snow melt" profile. It can be observed in Scandinavia and Italy and Alpine states: the snow starting to melt in March or April, it reaches a maximum around June and then starts to decrease.

Then, to assess the dam and the run-of-river local inflow, annual productions are used. It is assumed that the plant local inflow has the same profile as the flow rate of the cell, with an integral equal to the annual plant production. Mathematically, it gives:

$$\int_0^T inflow_{dam,c}(t)dt = E_{dam,annual,c} \quad (3.7)$$

$$\int_0^T inflow_{runriver,c}(t)dt = E_{runriver,annual,c} \quad (3.8)$$

3.3.6 Storage systems

Three different kind of storage are implemented: battery, PHES and gas storage. All the parameters of the storage systems are identical in each cell, except PHES installed capacities.

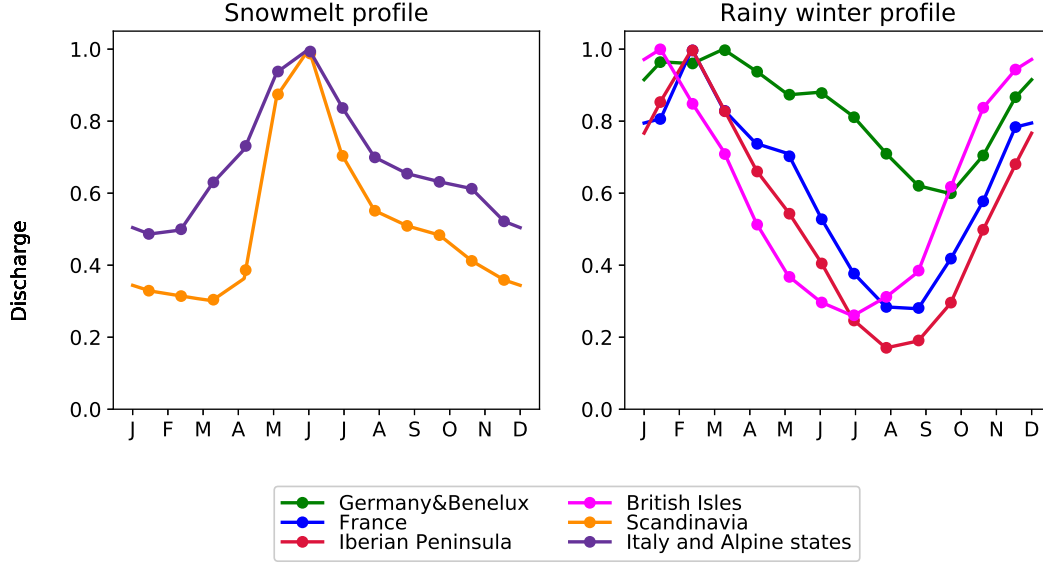

Figure 3.14: Normalised monthly discharge profile of the rivers per cell.

These common parameters are taken from [71].

Battery

The model of batteries implemented in the model is Lithium-ion batteries. Parameters used for this technology can be found in Table 3.8. As a reminder, α_{in} and α_{out} represent the charge and discharge rates, η_{in} and η_{out} the input and output efficiency, DoD the depth of discharge, γ the leak and $E_{cost/Wh}$ the energy cost per Wh of installed storage.

Table 3.8: Battery parameters.

Storage characteristic	Value
η_{in} [%]	90
η_{out} [%]	100
α_{in} [%/h]	20
α_{out} [%/h]	20
DoD [%]	80
γ [%/jour]	0.1
$E_{cost/Wh}$ [Wh/Wh]	132

PHES

PHES is the only storage whom parameters vary from one cell to another. The parameters varying are the installed power (pumping and generating) and the storage capacity. These are gathered for each cell in Table 3.9. The data are retrieved from a study of KU Leuven about large-scale stationary electricity storage plants in Europe [40].

Table 3.9: PHEs pumping, generating and reservoir capacity.

Cell	Reservoir [GWh]	$P_{turbine}$ [GW]	P_{pump} [GW]
Scandinavia	471.51	1.36	0.98
British Isles	28.50	3.08	2.94
Germany & Benelux	49.75	9.40	8.66
France	83.37	5.51	4.32
Italy and Alpine States	512.16	14.18	12.40
Iberian Peninsula	110.77	7.64	7.14

Parameters in common between the different cells are gathered in Table 3.10.

Table 3.10: PHEs parameters.

Storage characteristic	Value
η_{in} [%]	90
η_{out} [%]	85
DoD [%]	100
γ [%/jour]	0
ESOI [Wh/Wh]	704

Gas storage

Gas storage is composed of two parts: the PtG unit and the gas storage itself. PtG unit is used to fill the gas storage and CCGT power plants are used to convert the gas into electricity. Concerning the energy cost of the PtG, it is stated in [71]: "PtG being at lab scale, it has a low readiness level. Consequently, there are not many studies for the energy invested for a PtG unit. Hence, an educated guess value is taken for PtG at 100 MWh per installed power capacity of 1 MW". Furthermore, it is shown that this energy cost has a small effect on the results: "The energy cost has to be a thousand times more expensive (100 [GWh/MW]) for the PtG to have an influence on the results" [71]. Moreover, to avoid too high PtG installed power with severely low utilisation, a minimum utilisation factor of $\alpha_{PtG} = 15\%$ is set. Gas storage parameters can be found in Table 3.11.

Table 3.11: Gas storage parameters.

Storage characteristic	Value
η_{in} (PtG) [%]	63
η_{out} (CCGT) [%]	59
DoD [%]	100
γ [%/jour]	0
α_{PtG} [%]	15
$E_{cost/W}^{PtG}$ [Wh/W]	100
$E_{cost/Wh}^{gas}$ [Wh/Wh]	0.001

3.3.7 Transmission line capacities and import

The transmission line capacities are considered equal to the NTC. The Net Transfer Capacity (NTC) is defined based on the Total Transfer Capacity (TTC) and the Transmission Reliability

Margin (TRM). "The TTC is the maximum capacity available for the exchange of electricity between grids in neighbouring geographical areas without jeopardising the security of the respective grids. The TRM is the minimum reserve that system operators must have available at their connections so that they can help other countries to which their system is directly or indirectly connected, if necessary." [26]. The NTC is the capacity available for commercial transactions defined as $NTC = TTC - TRM$.

The NTC between the different countries used in this study are based on ENTSO-E NTC archives [28]. However, these values are from 2011. They could then suffer from inaccuracies with respect to the actual line capacities. These are presented in Figure 3.15. It is interesting to notice that the transfer capacities are not the same in both directions due to the asymmetrical topology of the grids connecting both ends of the transmission lines.

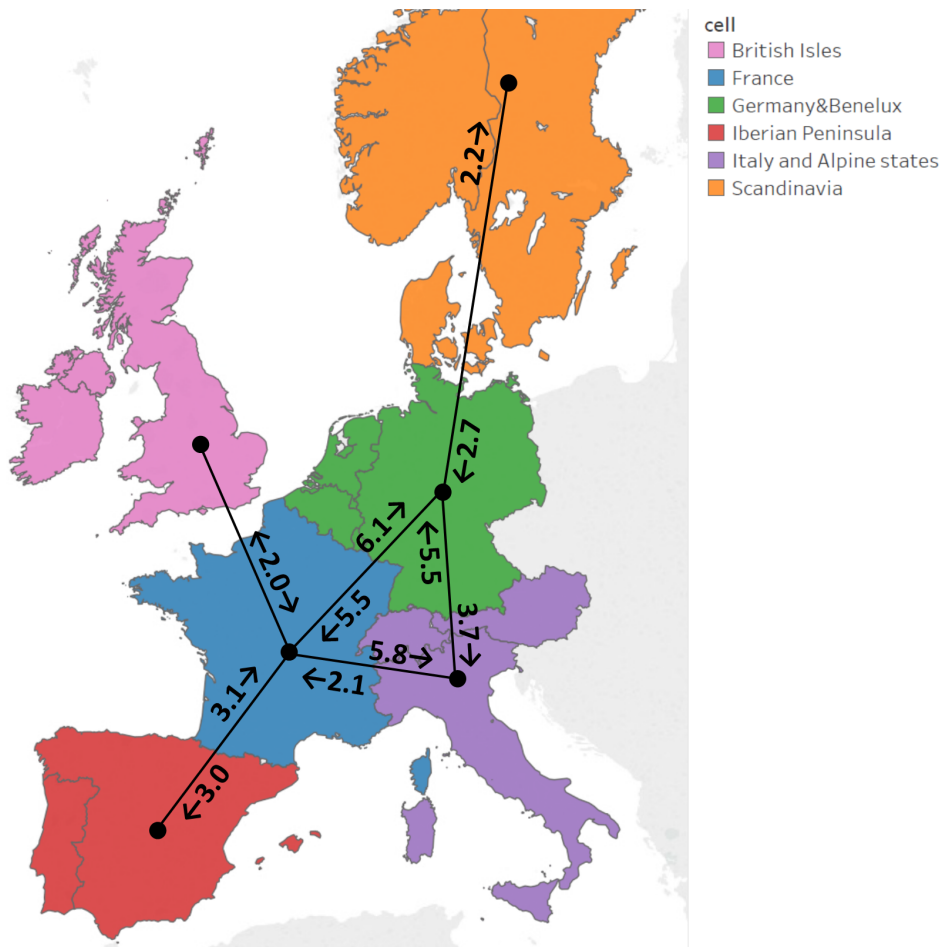

Figure 3.15: Net Transfer Capacity between cells [GW] [28].

The area under study is considered as a closed system. This means that no exchange with other area than the six cells defined are considered. The import from outside the system of each cell is thus set to zero.

3.3.8 Gas grid

No gas exchange between cells is considered in the model studied. No upper bound is set for the imported gas, meaning that a cell can import any amount of gas if necessary.

3.4 Limits and hypotheses

The data gathered for this study have been processed assuming sometimes strong hypotheses which have to be considered for the analysis of the results. Some of these hypotheses are discussed hereafter. Avenues for improvement are as well proposed.

3.4.1 Definition of the cells

Since several countries are gathered in one cell, the copper plate hypothesis is rough for some cells. Indeed, for example, countries in British Isles and Iberian Peninsula are not well connected. Additional cells could be implemented in order to take into account the possible transmission bottlenecks inside the actual cells.

3.4.2 Consumption

The reference electricity consumption profile used in the model is based on a particular year consumption (2017), when meteorological profiles are based on typical year and load factors on average values over 20 years. This could suppress some correlation between weather and consumption. Moreover, no potential increase of the consumption is considered. However, ENTSOE forecasts show that electricity consumption efficiency is estimated to increase as fast as the electricity consumption growth until, at least, 2025 [32]. No significant increase of the consumption is thus expected until there.

3.4.3 Actual production capacities

A first assumption made concerning the production capacities is the restricted means of production. Indeed, only a few kinds of means of production are represented in the model (see Table C.2). Thus, lots of different power plants have been gathered in a single asset. Furthermore, these installed capacities will quickly change in the coming years. Caution is required when assessing future scenarios.

3.4.4 Wind turbines

First, offshore load factors are not always well-known. Countries such as France, Spain and Italy do not have a sufficient number of installed offshore WTs to determine an average load factor. Moreover, even if available, the annual wind production can introduce uncertainties. For example, it can be observed in Table 3.3 that British Isles has a rather low offshore load factor while higher values are expected from Figure 3.2. This probably comes from the fact that old WTs in British Isles tend to lower the global load factor. A report from the Crown Estate on the United Kingdom offshore wind [34] states that recent WTs load factor lies between 40% and 45%. Furthermore, load factors are assumed constant for the whole offshore and onshore technical potential of a cell. However, in reality, all the potential installation sites taken into account in this study, presented in 3.4, will not present the same load factor. Another method would have been to base the load factor and technical potential on [24], which defines the technical potential of a country in function of a minimum EROI wanted.

Second, taking one wind profile for the whole cell is a strong assumption. Indeed, it is shown in [16] that cross-correlation coefficient of wind power production between the EU28 countries strongly decreases with respect to the distance separating two given locations. It is shown that already for 1000 km between two locations this coefficient can drop to a value between 0.2 and 0.4. Moreover, only two different WT parks are implemented and with a common base wind profile. This implies that if wind does not blow, the wind speed will be under the cut-in speed in both parks which corresponds to a case where none of all the WTs installed is producing. This situation is extremely rare at the scale of the cell since there is often at least one park where the wind blows

sufficiently to start WTs. This assumption increases the intermittent behaviour of wind power and can be seen as a worst-case scenario regarding wind production intermittency. However, if one observes the wind profiles used (non-scaled) and presented in Figure 3.16 which correspond, as said earlier, to typical years built on twenty years of measurements from Meteonorm [73], a strong correlation between the profiles is noticeable. Figure 3.16 presents the two-day average wind profiles in order to be able to distinguish the curves. If the hourly values are compared, one notices a strong correlation as well between the profiles. Indeed, by computing the Pearson correlation coefficient, the minimum correlation observed is between Iberian Peninsula (wind profile of Faro) and Scandinavia (wind profile of Halmstad) with a value of 0.91. This value denotes a strong relationship between these two profiles. This correlation coefficient value can reach 0.99 if France (wind profile of Saint Briec) and British Isles (wind profile of Norwich) are compared. With the data used, it is thus not useful to take several representative cities per cell.

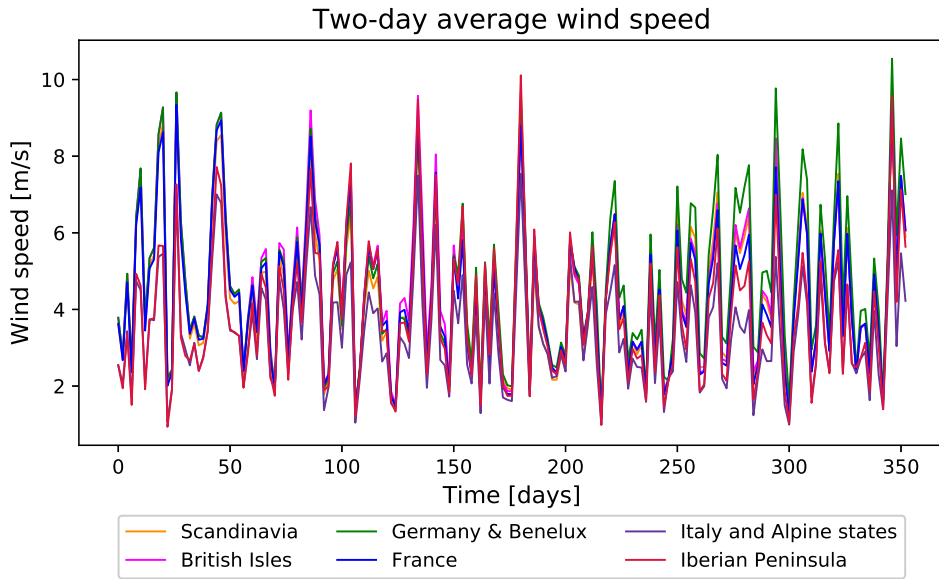

Figure 3.16: Two-day average wind profile of each cell.

Third, taking a unique cost for the offshore WT is a strong hypothesis. Indeed, as shown in [24], offshore WT cost highly depends on distance to shore and water depth.

3.4.5 PV panels

Only one park per cell is implemented for PV panels, meaning that only one load factor is used for each cell. As seen in Figure 3.3, irradiance can strongly vary between the south and the north of a cell. Moreover, as for wind, using only one irradiance profile worsens the intermittent behaviour of solar power since cloud coverage in a part of a cell does not imply that the complete cell is cloudy even if irradiance profiles in different locations of a country are highly correlated [16]. Looking at the Meteonorm hourly irradiance profiles used, the similar day/night profile is noticed for all profiles with a varying magnitude in function of the latitude. However, compared to the wind profiles, the distinct local hourly conditions are more perceived. When a decrease of the irradiance is observed in a cell, it is not necessary observed in the neighbouring cells. However, the Pearson correlation coefficient remains higher than 0.8 between the irradiance profiles of the cells. An average of the different profiles of the cells presented in Figure 3.12 could have been computed or multiple parks could have been implemented in order to obtain the global irradiance profile of the cell but at a certain computation cost.

3.4.6 Hydroelectric power plants

Hydroelectric power plant modelling is a tedious part. Indeed, data concerning these power plants are sometimes erroneous or ambiguous, mixing the different power plant types or even mixing storage (PHES) with production.

Then, the water inlet profile of the hydroelectric power plants is based on monthly water discharge in rivers at the level of the cell. The assumption of one profile for all the plants can be rough since some dams are located in mountains and some in lowland, having different profiles and shifting the available production from one part of the year to another.

Finally, as already mentioned, no conclusive data have been found to define the reservoir capacity of the dams. Reservoir capacity limits are thus set to 50% of the total annual inflow. This assumption influences the way dams power has to be produced during the year. Since the annual production of a hydroelectric power plant is defined beforehand and the output power is limited by the already-installed capacity, a small reservoir capacity compared to the local inflow will force the dam to execute multiple cycles when a high reservoir capacity will allow seasonal water storage.

3.4.7 Storage systems

The PtG installation energy cost is based on the previous work [71]. However, this value is a rough estimation since no study provides the energy investment cost for these kind of storage units. Moreover, the gas synthesised with the PtG units is burnt using the already-installed capacity of CCGT which is, in this study, a gathering of different power supply, and not only using gas as fuel (e.g. wastes). Moreover, no utilisation costs are implemented concerning the operation of those CCGT plants.

3.4.8 Transmission line capacities

The data of NTC between countries come from a report which dates from 2011 [28]. Since 2011, new lines have been built between certain countries or existing lines have been strengthened. For example, NTC archives only report one connection for UK, being the one from Sellindge (UK) to Calais (France). However, other lines exist such as the DC line between UK and Netherlands and the soon commissioned link between UK and Belgium. Other countries have built additional links since then and a deeper study of the European Net Transfer Capacities should be led to have a more accurate view of the actual import and export capacities between countries.

Chapter 4

Two-cell analysis: Germany & Benelux and France

A first two-cell system is studied in order to calibrate the model and to fully understand its behaviour before the analysis of the complete Western Europe system. This first study concerns the system composed of Germany & Benelux and France. The period of study is one year with a time step of one hour.

First, the optimal solution of the 100% RE electricity system with no external import is analysed by studying the exchanges between cells, the energy flows and the RE and storage assets. Second, the impact of the variation of the exchange capacity on the 100% RE system is evaluated. The results obtained for these two cells studied as an isolated system will be compared with the ones of the complete Western Europe study in the following chapter. An analysis of the variation of the RE and storage assets in function of the global RE share through transition scenarios has also been led. This analysis is not presented in the main body of the text but can be found in Appendix D.3.

All the inputs of the model are detailed in the previous chapter. As a reminder, Germany & Benelux has a population 1.6 times more important than France and has an annual electricity consumption of 724 TWh for the year considered compared to 479 TWh for France. The actual RE production share of Germany & Benelux is equal to 27% with an important wind and biofuel & waste production while the RE share of France is of 19% with an important hydroelectric production share. The actual exchange capacity from France to Germany & Benelux is 6.1 GW and from Germany & Benelux to France 5.6 GW.

The annual electricity consumption profiles are given in Figure 4.1. The two profiles are strongly different. The consumption profile of France shows a high seasonality with a strong decrease during the summer while the consumption profile of Germany & Benelux is more or less identical throughout the year. The seasonal variation of the French consumption is mainly due to the intensive use of electrical heating [70]. The important decrease of the production during the night for both profiles may also be pointed.

4.1 Study 1: 100% RE electricity system

In the present section, the 100% RE electricity system composed of Germany & Benelux and France with the actual transmission line capacity and without external import is analysed. The two cells are thus studied as a closed system. First, an overview of the energy investment is made. Second, a global analysis of the annual production and exchanges is conducted. Third, the energy flows on an annual and monthly timescale are detailed. Finally, the RE and storage assets of each cell are presented and analysed.

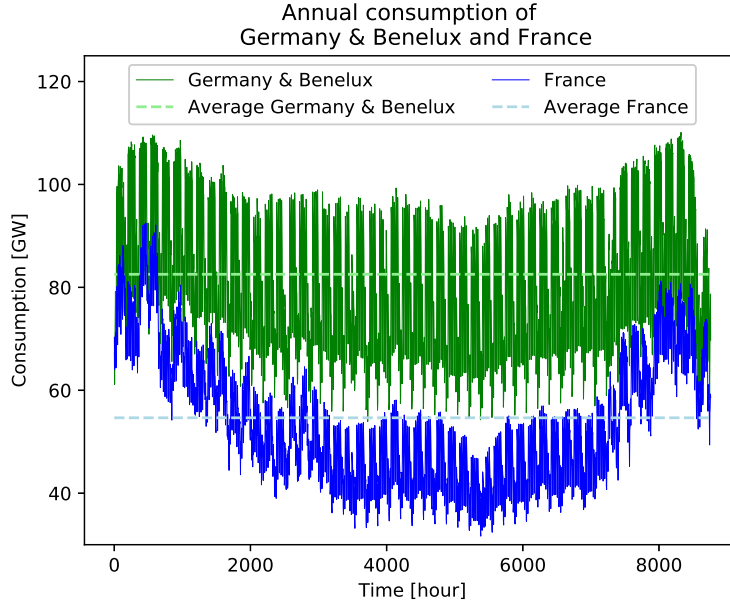

Figure 4.1: Annual electricity consumption and average of Germany & Benelux and France.

4.1.1 Energy investment

Table 4.1 summarises the energy investment of the system. The total energy investment is 152 TWh leading to a net EROI for the system of 7.88. The energy investment comes for more than 80% from the RE assets. From the 20% of the total energy investment invested in the storage, 93.5% lies in the batteries, 6.4% in the PtG and the rest in the gas storage and PHES. The important cost of the batteries and the negligible cost of the gas storage is there highlighted. From the total energy investment, 60% comes from Germany & Benelux and 40% from France. This is explained by a higher energy investment in RE assets of Germany & Benelux due to its higher consumption. However, despite the lower consumption of France, the energy invested in storage is higher for that cell. The reason of this is explained in the following sections.

Table 4.1: Energy investment of the system and of each cell.

	System [TWh]	Germany & Benelux [TWh]	France [TWh]
RE assets	125	81	44
Storage	27	10	17
Total	152	91	61

4.1.2 Production and annual exchanges

Figure 4.2 resumes the production and the annual exchanges between the cells. In the arrow is presented the annual energy exchanges as well as the net value.

France production relies mainly on offshore WTs (82% of its production) while in Germany & Benelux the production is more diversified: 49% from offshore WTs, 33% from onshore WTs, 16% from PV panels and a negligible hydroelectric production.

One can notice that France is an electricity exporter on an annual timescale and Germany & Benelux an importer. The net annual import of Germany & Benelux (34.7 TWh) corresponds to 3.8% of its electricity needs and to 6.2% of the French production. It is noticeable that, even if Germany & Benelux has an importer behaviour, it exports electricity to France as well

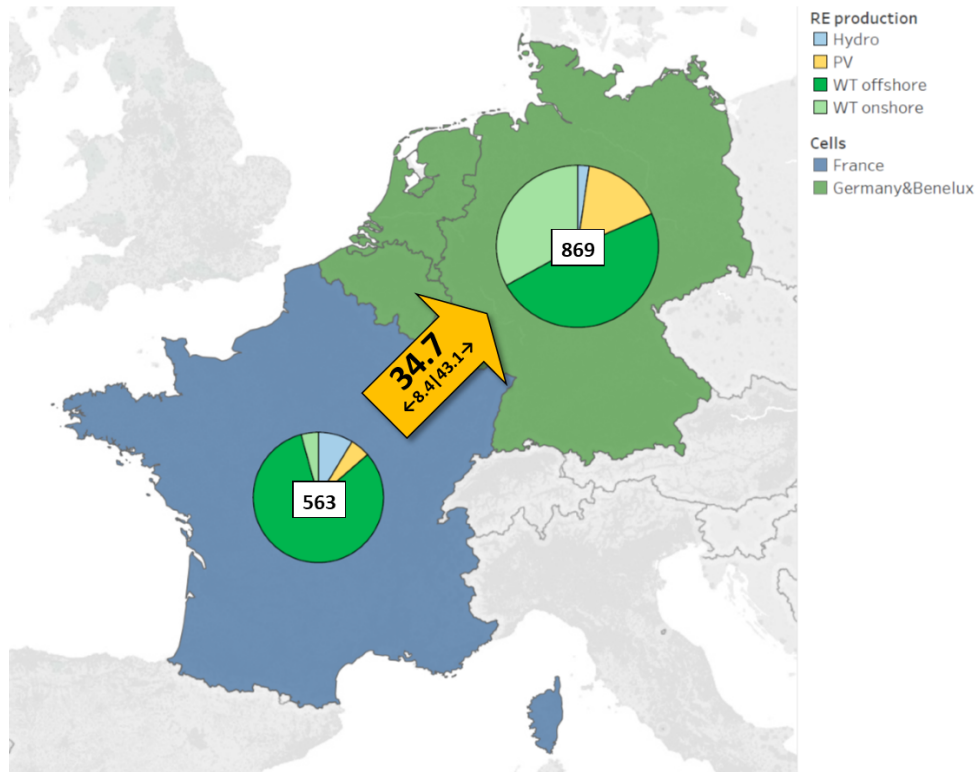

Figure 4.2: RE production and annual exchanges (total exchanges and net exchange) [TWh]. The yellow arrow represents the net exchange while the sub-arrows represent import and export.

(8.4 TWh). The net EROIs of France and Germany & Benelux are 7.79 and 7.95 respectively. Germany & Benelux takes advantage of the French production which lowers the EROI of France.

The utilisation factor of the line is equal to 98% and more than 95% of the time the line is used at its maximum power. Exchanges are thus clearly limited by the capacity of the line. Study 2 in Section 4.2 will focus on the impact of this parameter.

The terms "*import*", "*export*", "*net import*" and "*net export*" are used in the following sections. The "*import*" corresponds to the sum of all the energy imported and consumed in the cell over the period defined. The "*export*" corresponds to the sum of all the energy produced in the cell that is exported. The difference between "*import*" and "*export*" corresponds to the "*net import*" of the period defined if this value is positive and to the "*net export*" if negative.

4.1.3 Energy flows

In this section, the energy flows of the system are presented and studied for different timescales: annually in Figures 4.3 and 4.4 and monthly in Figure 4.5.

Figures 4.3 and 4.4 resume the global energy flows of the cells for the period studied. They highlight the part of production directly consumed, exchanged and stored.

Looking at Figures 4.3 and 4.4, one notices that, in order to reach the optimal solution based on the energy cost, storage plays a key role in the electricity system. Indeed, at the level of the global system, more than 40% of the energy production passes through the storage before being consumed: 22% enters the PtG unit, 21% the batteries, and 0.4% the PHES. It is important to stress that the three storage systems implemented are used. The global losses due to the storage represent 16% of the energy produced and 37% of the energy entering the storage. These two figures also allow to clearly highlight the storage mix installed by each cell. In Germany & Benelux, two thirds of the energy entering the storage enters the PtG unit and one third the batteries. On the other hand, in France, three quarters enters the batteries and one quarter the

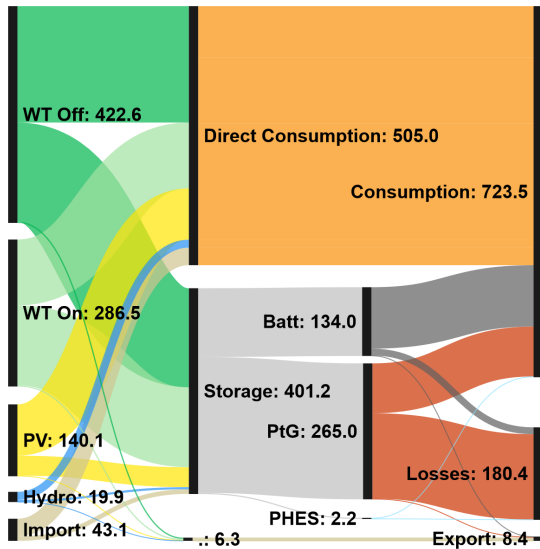

Figure 4.3: Sankey diagram of Germany & Benelux annual energy flow [TWh].

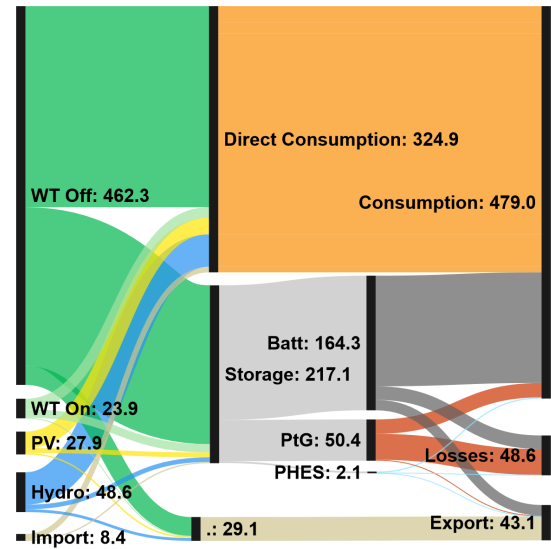

Figure 4.4: Sankey diagram of France annual energy flow [TWh].

PtG. The storage mix is thus dependent on the characteristics of the cell. The high losses due to the conversion of electricity into gas and then of gas to electricity is noticeable: only one third of the energy entering the PtG is finally consumed. For both cells, the energy consumed coming from the storage represents 30% of the consumption. However, due to the higher utilisation of the gas storage in Germany & Benelux leading to high storage losses, a more important part of the production has to be stored for that cell.

From Figures 4.3 and 4.4, one can also observe the important difference of the share of direct consumption between the different means of production. For both cells, the main part of the PV production is directly consumed while for the WTs approximately half passes in the storage. It is also noticeable that, for both cells, 80% of the import is directly consumed and that the export comes mainly from direct RE production (without storage).

No curtailment is observed in the system, which means that all peaks of production are adsorbed. Indeed, as explained later in this section, the batteries being sized based on their storage capacity (and not by a power limit) have an oversized available input power and can thus absorb all the short-term peaks of production. The PtG, not having a maximum power limit, is sized in order to absorb all mid-term variations of production. Battery and PtG combined are thus able to absorb all production surplus leading to no curtailment. On the opposite, an important curtailment was noticed for the 100% RE Belgium analysis (19%) as presented in [71]. This is explained by the high solar share of the electricity system, its limited PtG capacity and its inability to exchange energy (no import/export). A curtailment was thus observed during the summer due to the important increase of solar production and the inability of the PtG to store it because it has reached its limited power.

Figure 4.5 displays the monthly production, consumption, net storage variation and net exchange of the two cells. The positive bars correspond to the total monthly production, net output of storage and net import of the cell while the negative bars correspond to net input of storage and net export. The difference between positive and negative bars corresponds thus to the monthly consumption, storage losses and curtailment (no curtailment here). It allows to study the evolution of the energy flows throughout the year and underlines seasonal behaviours.

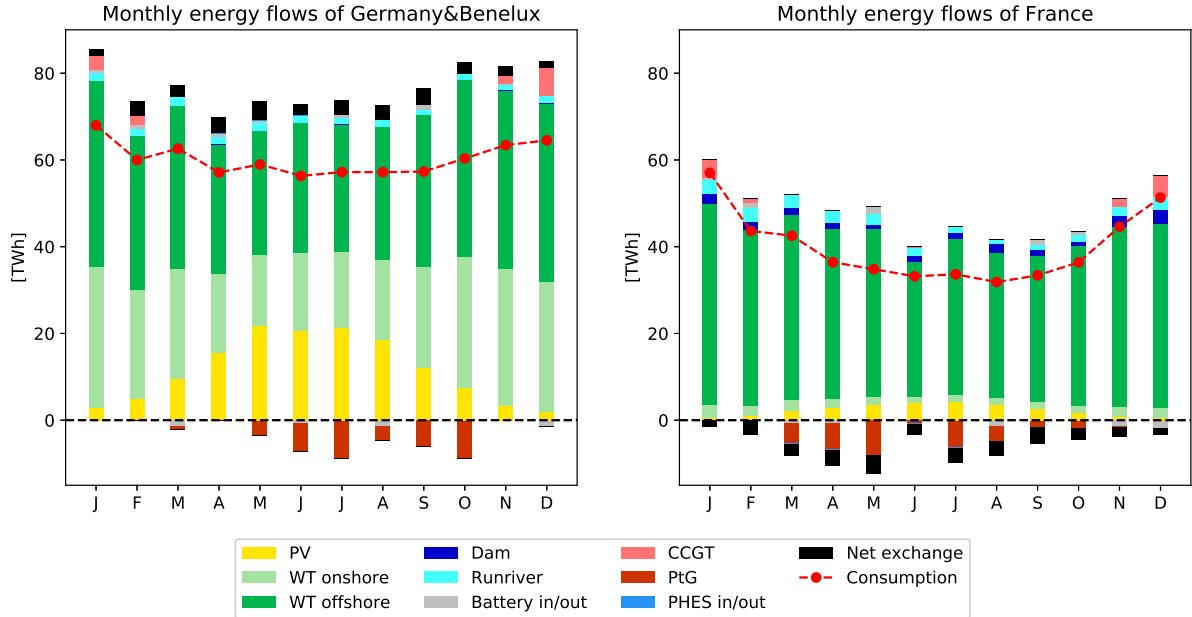

Figure 4.5: Monthly energy flows of Germany & Benelux and France. Net exchange corresponds to the net import (>0) or net export (<0) of a cell.

The different energy mix of the two cells can clearly be identified from Figure 4.5. One notices the strong seasonality of both wind and solar productions. The wind production presents a drop during the summer months and the opposite is observed for solar. The complementarity of both means of production (WT and PV) is used in Germany & Benelux such that the monthly production remains nearly constant throughout all the year. The dependence of France on only one technology leads to a strong seasonal variation of its production which is however synchronised with its consumption. Considering the gas storage, in France, it is filled from Mars to October and emptied during the months of winter when the consumption faces an important increase. In Germany & Benelux, it is filled from May to October when solar and wind productions are high. In both cases, a strong seasonality is observed. The evolution of the gas storage of the two cells is presented in Figure 4.10. One observes that only one cycle is performed. Regarding the net exchanges, France has during the entire year an exporting behaviour and the value of its exports lowers during the months of high energy needs (November to January).

Interesting observations can be made by analysing the hourly energy flows. In Appendix D.2, an example of hourly analysis is presented, analysing briefly the energy flows of a week of winter and a week of summer for the two cells.

4.1.4 RE assets

A summary of the solution for the RE and storage assets of the case studied is presented in Table D.1.

Figure 4.6 displays the RE assets of the 100% RE system in nominal power (Watt-peak for the PV). The upper and lower limits of each RE asset (horizontal black lines) as well as their domain of solutions (vertical dotted lines) are represented. If the upper limit is not visible, it is because it is higher than 200 GW. Table 4.2 reminds of the gross EROI of the RE assets of each cell.

The RE assets installed are strongly different for the two cells: France installs only a significant number of offshore WTs, while Germany & Benelux installs a consequent amount of the three proposed technologies. It reflects directly the production mixes presented in Section 4.1.2. The gross EROI of each RE asset presented in Table 4.2 does not fully explain the solution obtained.

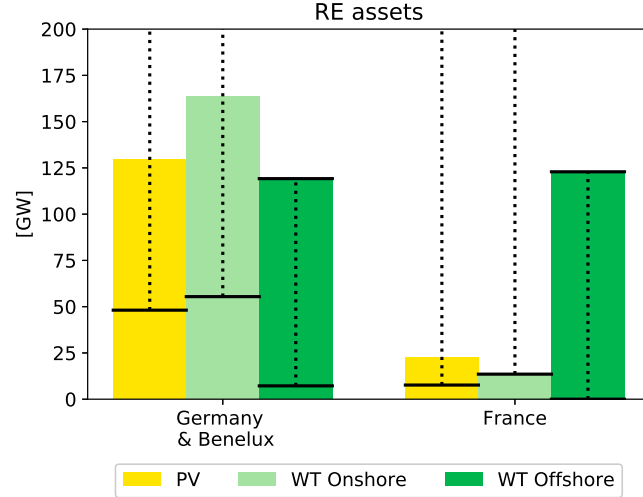

Figure 4.6: Nominal power of the RE assets. The horizontal black lines correspond to the upper and lower limits and the dotted lines to the domain of solutions.

Table 4.2: Gross EROI of the RE assets.

Cell	RE asset	EROI
Germany & Benelux	PV	7.57
	WT Onshore	11.69
	WT Offshore	11.13
France	PV	8.63
	WT Onshore	11.79
	WT Offshore	11.81

Indeed, in Germany & Benelux, the upper limit of offshore WTs is reached before the upper limit of onshore WTs even though the EROI of the first is lower than the EROI of the second. Moreover, PV panels are installed in that cell while their EROI is much lower than the EROI of both WT parks. Finally, PV panels are installed in Germany & Benelux and not in France while the EROI of the latter is higher than the EROI of the first. It can thus be noticed that, even if the EROI plays a role in the optimisation of the RE assets, it is not the only influencing parameter.

As already mentioned, the energy produced by the different technologies is not similarly absorbed by the consumers. Part of the production is consumed directly while the rest passes through the storage inducing additional energy costs due to the losses and to the energy cost of the storage system itself. The assimilation of the production is thus another key parameter to understand the optimal solution obtained. It is important to note that the absorption of the production of a specific technology depends on the other means of production present in the mix as well as on the power installed of that technology: the more power is installed, the less efficient is the absorption due to the more important peaks and drops of production compared with the consumption profile. Table 4.3 details the absorption of the RE assets of each cell. PHES, corresponding to less than 1% of the total energy stored, is not represented.

Despite their lower EROIs than onshore WTs, the installation of PV panels and offshore WTs in Germany & Benelux is explained looking at the assimilation of the different means of production. Indeed, the direct consumption of the solar production is of 73% and of 55% for the offshore WTs, while for the onshore WTs it is of 45%. The lower EROI of the PV panels and

Table 4.3: Absorption of the RE production of the two cells.

Cell	RE asset	Direct consump. [%]	Batteries [%]	PtG [%]
Germany & Benelux	PV	73	15	12
	WT onshore	45	15	40
	WT offshore	55	15	30
France	PV	76	17	7
	WT onshore	55	33	11
	WT offshore	56	34	11

offshore WTs in comparison with the EROI of the onshore WTs is thus compensated by a more efficient absorption by the consumption. The better absorption of the solar production is due to its synchronisation with the consumption, both showing day/night cycles. Concerning offshore wind, it has a higher mean production than onshore (due to its load factor). Thus, for the same energy produced, more onshore WTs have to be installed leading to higher peaks of power in case of strong winds which gives rise to a higher mismatch between production and consumption inducing storage needs.

The fact that France does not install a significant number of PV panels in comparison with Germany & Benelux is explained by looking at the consumption profiles of the two cells presented in Figure 4.5. As said earlier, those two profiles are strongly different: France consumption increases during winter while Germany & Benelux consumption profile is rather identical throughout the year. The French consumption is thus not adapted to solar electricity production which is higher during the summer than during the winter. An important share of PV production in France would require a high long-term storage capacity leading to high losses. Only offshore and no onshore WTs are installed due to the better EROI and absorption of the offshore parks. However, these values are close. The EROI of the offshore WTs is less than 1% higher and the absorption are nearly identical, as pointed in Table 4.3. An analysis of the RE assets in function of the EROI of the onshore WT parks of France is thus led to evaluate the stability of the solution obtained.

Sensibility analysis of the RE assets

As mentioned hereabove, in France, the absorption of the production of both WT parks is nearly identical with only a slightly higher value for the direct consumption of the offshore parks (56% offshore, 55% onshore). In addition to this, the EROI of the offshore WTs is a little bit higher. Only offshore and no onshore WTs are then installed. A small change of the value of the EROI could thus drastically change the solution. In order to quantify the influence of this parameter, a sensibility analysis of the RE assets installed with respect to the EROI of the onshore WTs of France is performed.

The two parameters influencing the gross EROI of the WTs (without modifying the power curve and lifetime) are the energy cost and the load factor. Indeed, with $E_{cost/WT}$ the energy cost of one WT, LT_{WT} its lifetime, $E_{prod/WT}$ the energy produced by the WT throughout its lifetime, $P_{n,WT}$ its nominal power and LF_{WT} its load factor:

$$EROI_{WT} = \frac{E_{prod/WT}}{E_{cost/WT}} = \frac{P_{n,WT} LT_{WT} LF_{WT}}{E_{cost/WT}} \quad (4.1)$$

An increase of 10% of the gross EROI can thus be made by an increase of 10% of the load factor, or by dividing the energy cost by 1.1. However, changing one or the other does not lead to similar results. Indeed, modifying the load factor of the WT parks causes a change of the production profile affecting the way power is absorbed by consumption. Figure 4.7 displays the sensibility

of the RE installations to the EROI of onshore WTs in France regarding these two parameters. Only the variations of the RE assets in France are represented, the ones of Germany & Benelux varying by less than 5% of their actual value.

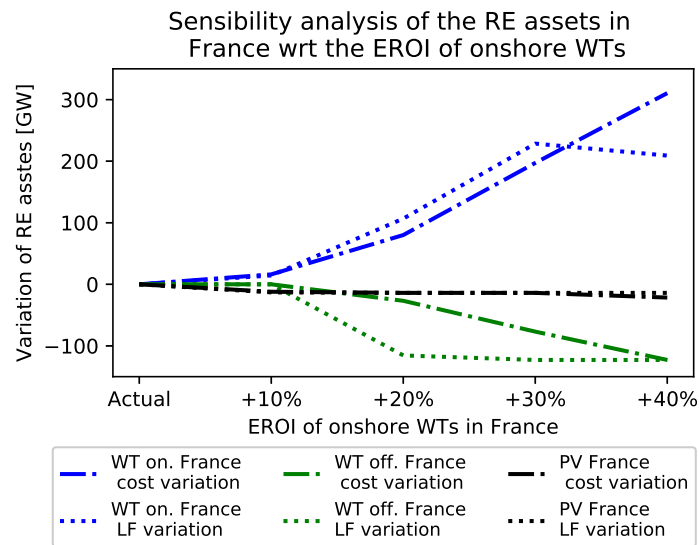

Figure 4.7: Sensibility analysis of the RE assets in France with respect to the EROI of onshore WT.

It appears that the number of onshore and offshore installed WT varies strongly with respect to the onshore EROI while the PV panels installed remain constant. Moreover, the evolution of the assets is different if the EROI is changed by modifying the cost or the capacity factor. The solution is more sensitive to a change in load factor for variations between 10 to 20%. As observed, an increase of 20% of the onshore EROI by increasing the load factor is sufficient to heavily change the results. At that point, the system replaces nearly all the offshore WTs by onshore WTs. In the case of a variation of the investment cost, it requires an increase of 40% of the EROI before obtaining the complete replacement of the offshore WTs. The possibly high sensibility of the solution for RE assets with close EROI and absorption profiles has to be kept in mind for analysing the further results. Indeed, the values found or computed to obtain the energy costs and load factors are based on several hypotheses as detailed in Section 3.

4.1.5 Storage assets

Figure 4.8 presents the optimised storage assets of the system. PHES is not represented since its installed capacity is fixed. As said in Section 4.1.3, it is interesting to stress that, to reach the optimal solution, both battery and gas storage are installed.

Germany & Benelux battery installed capacity is equal to 1.6 TWh. In order to represent the volume occupied by such batteries, Tesla Power pack lithium-ion technology is chosen as a reference [88]. These batteries correspond to the technology used in the study and are already implemented as grid storage facilities [66]. Based on the characteristics of the Powerpack, Germany & Benelux installs the equivalent of 0.16 m³ of batteries per inhabitant. France, on the other hand, installs 3.4 TWh of batteries, corresponding to a volume of 0.55 m³ per inhabitant.

Comparing the storage assets and observing the annual inputs of energy in the storage systems presented in Figures 4.3 and 4.4, one observes that France storage relies mainly on batteries while Germany & Benelux on gas: 75% of the energy stored in France is stored in the batteries and 65% of the energy stored in Germany & Benelux is stored in the gas storage system. In both cells, PHES plays a minor role.

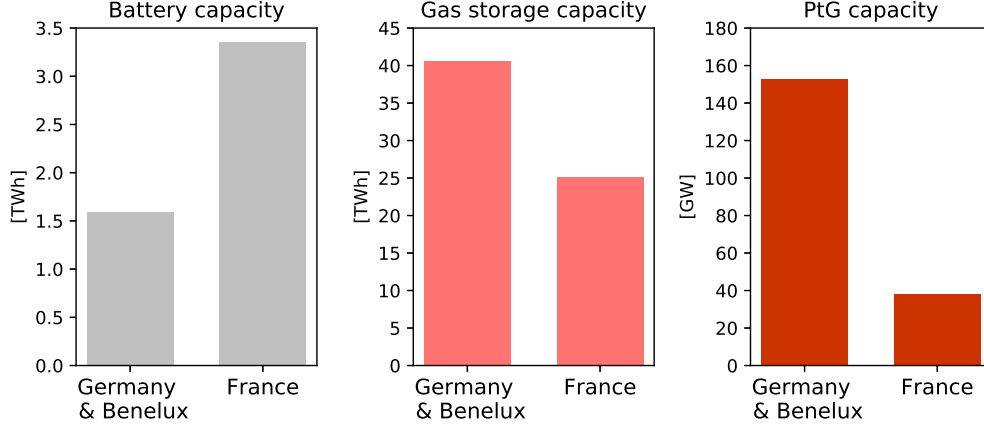

Figure 4.8: Storage assets of the two-cell system.

In order to understand the storage assets of the optimal solution, it is interesting to analyse their energy cycles. It is expected from the batteries to have a short-term usage, for the PHES a mid-term one and for the gas storage a long-term one. Indeed, the distinct utilisation of the storage systems are explained by their respective costs and efficiencies. Batteries have a high cost per Wh installed (132 Wh/Wh), meaning that storing high energy quantities only one time will not be interesting for the system. However, the efficiency of the batteries is high compared to the efficiency of the gas storage. Indeed, a storage cycle has an efficiency of 90% for the batteries compared to 37% for the gas. On the other hand, the cost of the PtG is related to its installed power, meaning that absorbing high power peaks is costly for the system but the gas storage is extremely cheap compared to batteries (0.001 Wh/Wh). The system will then naturally tend to use batteries to store production peaks with a limited installed storage capacity by storing the energy for a short period and use the gas storage as a long-term seasonal storage with a low installed PtG power and an important gas storage. Concerning PHES, it will only store energy after the batteries are full and before energy starts to be stored in the gas storage. Indeed, it presents a lower efficiency (round trip efficiency of 75%) than the batteries but higher than the gas storage.

The utilisation of the storage system is presented in Figure 4.9. It presents the number of cycles achieved by a given storage system over the year for different cycle durations. The number of cycles is determined as follows. First, the total annual energy cycled in the given time range is computed. The energy cycled in a storage corresponds to the quantity of energy which entered and left the storage within a certain period. The storage is considered as a stack, meaning that the last energy unit entered in the storage is the first one to leave. Then, this energy is divided by the storage capacity of the technology studied to obtain the number of cycles. One has to notice that a cycle does not necessarily happen at once. For example, 1 Wh entering and leaving the storage in less than 24 hours 10 times on 10 different days in a storage of 10 Wh is considered as a single cycle achieved in less than 24 hours.

From Figure 4.9, it is noticeable that the expected utilisation of the storage systems is globally met. Indeed, in Germany & Benelux, the batteries are mainly used for short-term storage needs (<24h) due to short-term variations of the production and demand while gas storage is used for mid-term (one week-one to month) and long-term (>month). The mid-term storage needs mainly come from wind production drops, as detailed hereafter, and the long-term from the seasonality of the solar production. The seasonal behaviour of the gas storage is highlighted in Figure 4.10. One can observe an increase of the storage level in spring and summer, and a decrease during autumn and winter, as mentioned in Section 4.1.3.

Contrary to expectations, France uses as much its battery storage for the short-term (<24 hours) than for the mid-term (from one day to one month). The distinction in the utilisation

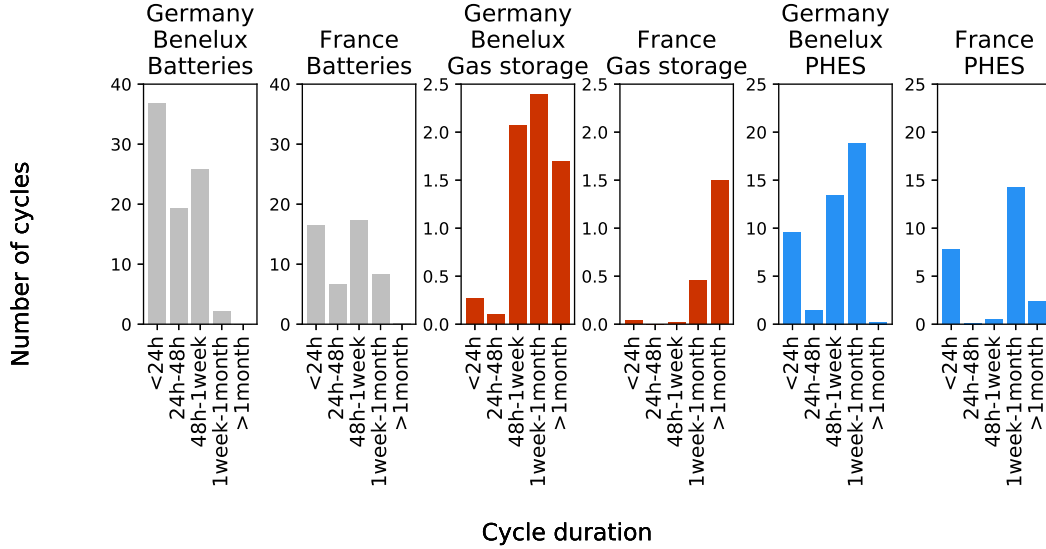

Figure 4.9: Number of cycles of the storage assets.

of the batteries is not as clear as for Germany & Benelux. Moreover, the number of cycles of the batteries is much lower for France. This is explained by the fact that the ratio of the CCGT installed power to the average power consumption is three times lower in France than in Germany & Benelux (0.3 and 0.9 respectively). Its CCGT is thus not able to overcome the power needs faced during mid-term drops of production and batteries are used instead. The batteries are then used to cover the short and mid-term storage needs leading to an important battery capacity while the gas storage is only used to compensate the seasonality of the production and consumption.

For both cells, PHES is indeed used as a complement of the two other storage systems. It is used for short-term storage when batteries are full and for mid-term before the gas storage due to its better efficiency. Moreover, due to its low (and limited) capacity, it covers only a very small part of the mid-term needs which have thus to be covered by the other storage systems. Indeed, as detailed in Section 4.1.3, only 1% of the energy stored is stored in the PHES.

Regarding the battery storage of both cells, the storage maximum capacity is reached multiple times during the period of study while never the maximum power. It means thus that the battery storage is sized based on the energy need constraint which exceeds the power need constraint. As said here above, the important battery power combined with the PtG is able to absorb all peaks of production leading to no curtailment.

As pointed in Table 4.3, in Germany & Benelux, more than two thirds of the energy stored from the production of the WTs is stored in the PtG and the rest in the batteries, while for the PV panels half is stored in the PtG and half in the batteries. This is explained by the important short-term variations of the PV panels (day/night behaviour) in comparison with the mid-term variations of the WTs. Indeed, WTs mean production can drop under 25% of the mean consumption during up to one week in both cells. In France, one quarter of the energy stored from the WT is stored in the PtG and three quarters in the batteries, as well as for the PV. It highlights again the intensive use of the batteries and their utilisation for short and mid-term storage.

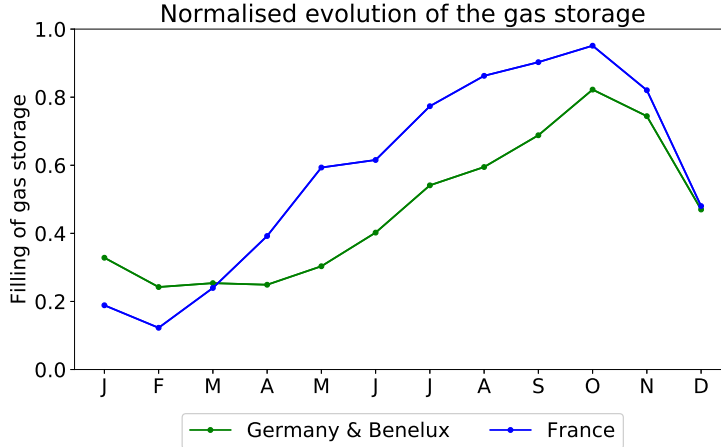

Figure 4.10: Normalised monthly evolution of the gas storage, based on the content of the last day of the month.

4.2 Study 2: Impact of the exchange capacity

Interconnection may play a key role in the energy transition. As stated in the introduction of this work, the Europe Council called for all EU countries to achieve interconnection of at least 15% of their installed electricity production capacity by 2030 [19, 87].

The aim of this section is to study the impact of the exchange capacity on the energy investment and on the RE and storage assets. As for the previous study, the electricity system analysed is the 100% RE two-cell electricity system composed of Germany & Benelux and France without external import. The cases studied are: without interconnection, with the actual line capacity and with two, five and ten times the actual capacity. The energy cost induced by the increase of the exchange capacity is not considered. The scenario without interconnection is a theoretical scenario used to analyse the behaviour of the cells when they are isolated. One has to note that the case with the actual line capacity corresponds to the one presented in the previous study. As a reminder, the actual exchange capacity from France to Germany & Benelux is 6.1 GW and from Germany & Benelux to France 5.6 GW.

First, the variation of the energy investment is analysed. Second, the variation of the RE assets is studied. Finally, the impact of the line capacity on the storage is evaluated.

In the following sections, stacked bar charts of values of the two cells are presented. The two cells being characterised by a distinct number of inhabitants and total consumption, it is important to keep in mind that the results cannot be directly compared. If a comparison between the values obtained for the two cells has to be made, these differences are taken into account.

4.2.1 Energy investment

The evolution of the energy investment in function of the exchange capacity is presented in Figure 4.11.

The global energy cost being the objective function that has to be minimised, decreasing the constraints of exchange increases the degree of freedom of the system and can only lead to an equal or lower optimal value. Indeed, the global energy investment of the system lowers with the increase of the exchange capacity. A decrease of 4.5% from no line to 10x the actual capacity is observed with a decrease of 3.5% of the energy invested in RE assets and of 11% of the energy invested in storage. From Figure 4.11, it is noticeable that, for all the cases, approximately 80% of the energy cost comes from the RE assets. Moreover, one can notice a transfer of the energy investment from Germany & Benelux to France as well as an increase of the energy invested

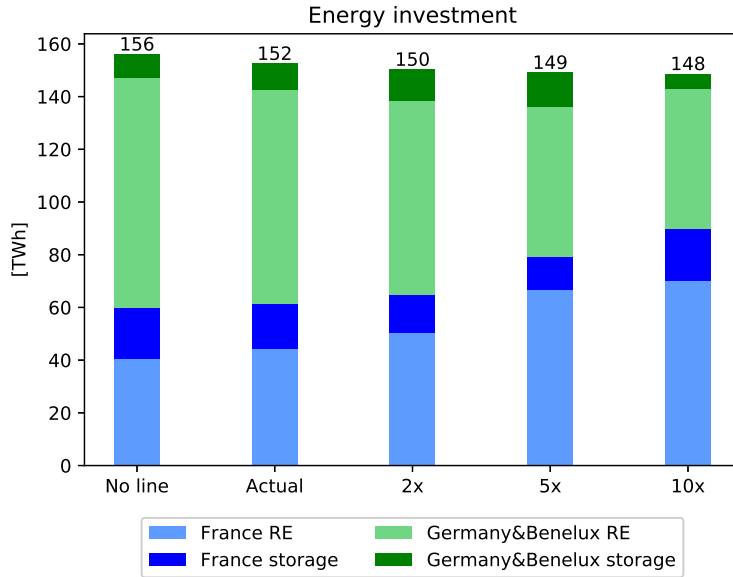

Figure 4.11: Energy investment in function of the exchange capacity.

in storage in France from 5x to 10x the line capacity. The reasons of these observations are explained in the following sections.

The evolution of the net EROI of the system is presented in Table 4.4. This evolution is directly linked to the variation of the energy investment, as the consumption is identical for all the cases. The net EROI increases thus with the increase of the line capacity. In the case with no exchange limit, which corresponds to consider the system as one cell, the net EROI is equal to 8.09. Regarding the energy investment, the case 10x the actual line is thus identical to the case with an infinite line. It shows that the improvement of the EROI by the increase of the line capacity has a limit and this limit is already reached in the last case.

Table 4.4: Evolution of the net EROI in function of the line capacity.

Case	net EROI
No line	7.70
Actual	7.88
2x	8.00
5x	8.06
10x	8.09

4.2.2 Production and annual exchanges

Table 4.5 resumes the ratio of the annual production to consumption of each cell and of the total system as well as the percentage of production directly consumed in function of the line capacity.

A transfer of production from Germany & Benelux to France appears with the increase of the line capacity, enhancing the importing behaviour of Germany & Benelux. For the cases with 5x and 10x the actual exchange capacity, Germany & Benelux is strongly dependent on France which production represents more than 1.6 times its consumption. Such scenarios are unlikely to happen due to the actual will of energy independence of the countries.

In addition to the results provided in Table 4.5, it can be pointed that, even if the production and net export of France increase, its annual import also increases. Indeed, this value rises

Table 4.5: Ratio of the annual production to consumption in function of the line capacity and percentage of production directly consumed.

Case	Germany & Benelux	France	Total	Directly consumed [%]
No line	1.29	1.09	1.21	55
Actual	1.20	1.17	1.19	59
2x	1.10	1.28	1.17	65
5x	0.88	1.60	1.16	73
10x	0.81	1.67	1.16	73

from 8.4 TWh for the actual line to 49.2 TWh for 10x the actual line capacity. This shows that higher exchanges in both directions are advantageous for the system. Indeed, as shown in Table 4.5, the percentage of production directly consumed increases at the same time as the line capacity increases. It can then be stressed that being well interconnected allows more bidirectional exchanges and thus to consume more directly the electricity produced (without passing through storage). This leads to a decrease of the storage assets as well as of the storage losses. A decrease of the energy production is therefore also observed. As for the evolution of the EROI, a limit of the increase of direct consumption is observed.

Table 4.6 presents the utilisation of the line. One notices that in the case of 2x and 5x the actual line, the utilisation factor is still superior than 90%. With 10x the actual line capacity, the utilisation factor drops to 65%.

Table 4.6: Line utilisation factor in function of the line capacity.

Case	Line utilisation [%]
No line	/
Actual	98
2x	95
5x	90
10x	65

4.2.3 RE assets

The evolution of the RE assets in function of the exchange capacity is presented in Figures 4.12 and 4.13. A summary of the solutions for the RE and storage assets of the different cases is presented in Tables D.2 and D.3. As a reminder, the gross EROI of each RE source is presented in Table 4.2.

A transfer of RE assets from Germany & Benelux to France with the increase of the line is clearly noticed.

With no line, France installs only offshore WTs. This is due to the fact that, as explained in the first study (Section 4.1) France does not have a consumption profile adapted for solar production. Moreover, the offshore WTs present a better EROI and a better absorption than the onshore installations. On the other side, Germany & Benelux installs the three means of production. As for the previous study, the better EROI of the onshore WTs compared to the offshore WTs and PV panels is compensated by the better absorption of the last two (direct consumption of 43%, 52% and 71% respectively).

With the increase of the line capacity, the PV panels and onshore WTs of Germany & Benelux are transferred to France. As presented in Section 3.3, the meteorological data present a high

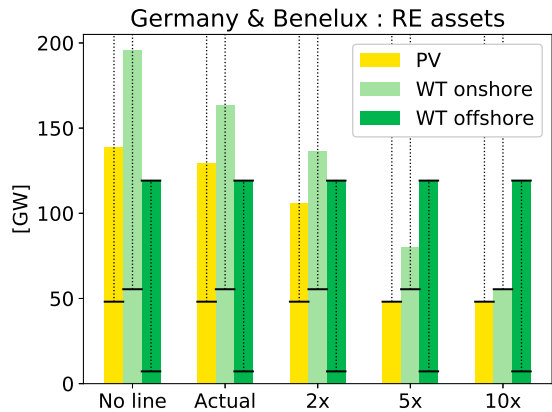

Figure 4.12: RE assets in function of the line capacity in Germany & Benelux.

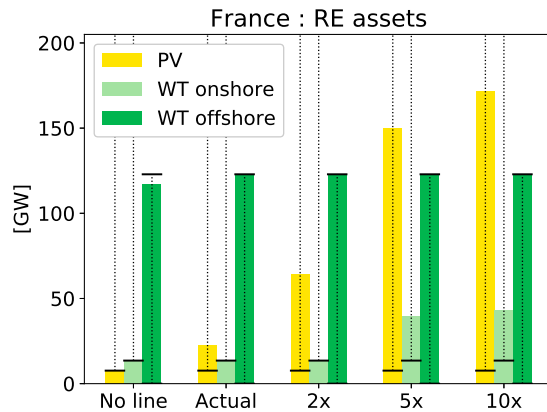

Figure 4.13: RE assets in function of the line capacity in France.

similarity between the cells. The Pearson correlation coefficient between the wind profiles of Germany & Benelux and France is equal to 0.98 and between the irradiance profiles to 0.85. This leads to a similar absorption by the consumption for a given cell if its production is located in that cell or in another. The system tends therefore to install each RE assets in the cells presenting the best EROI but is limited by the exchange capacity of the line. The transfer of the PV panels and onshore WTs of Germany & Benelux to France is thus explained by the higher EROI of both technologies in France. It is interesting to notice that France only installs a consequent capacity of PV panels if well-connected to a cell with an adapted consumption profile.

If the constraint of the maximum exchangeable power is suppressed (infinite line capacity), the solution for the RE assets is identical to the one obtained for the case 10x the actual line. In this case, an important capacity of PV panels is installed in France and the upper limit of both offshore WT parks is reached as well as the lower limit of onshore WTs and PV panels in Germany & Benelux. This corresponds thus to the most efficient production mix if no transmission constraints are faced, under the hypotheses of the model.

4.2.4 Storage assets

The variation of the storage assets in function of the exchange capacity is presented in Figures 4.14, 4.15, 4.16 and 4.17. As explained in Section 1.2, the capacity of the PHES is fixed and is thus not represented here. Moreover, for both cells and in all the cases studied, PHES represents a minor part of the power and capacity of the storage.

With no line, France energy storage relies mainly on batteries: 73% of the energy stored goes to the batteries, 21% to the gas storage and 6 % to the PHES. On the opposite, Germany & Benelux relies mainly on the gas storage: 70% of the energy stored goes in the gas storage, 29% in the batteries and 1% in the PHES. Those distinct storage mixes are due to the low installed power of CCGT in France leading to an important battery storage used for mid-term utilisation, as detailed in the previous study.

As shown in Table 4.5, the fraction of the total production stored lowers with the improvement of the interconnection leading to a decrease of the total production and of the global storage needs. Moreover, with the increase of the line, the storage mixes in both cells tend to be more balanced. The battery capacity decreases in France while increasing in Germany & Benelux and the opposite phenomenon is observed for the PtG. Indeed, with higher exchange possibilities, the system tends to place the same amount of batteries in both cells since installation costs are the same. The variation of the PtG installed power is explained by the same reasons.

Between the cases 5x and 10x the actual line, a behaviour contrary to the evolution of the

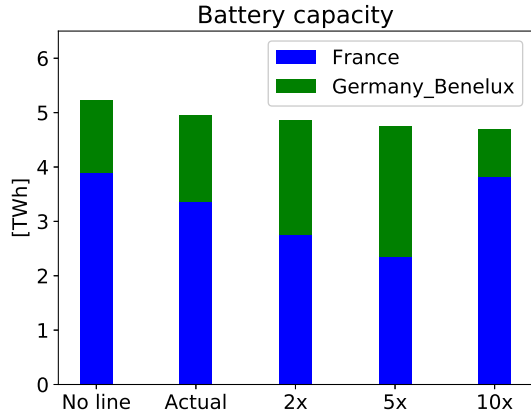

Figure 4.14: Battery capacity in function of the exchange capacity in Germany & Benelux and France.

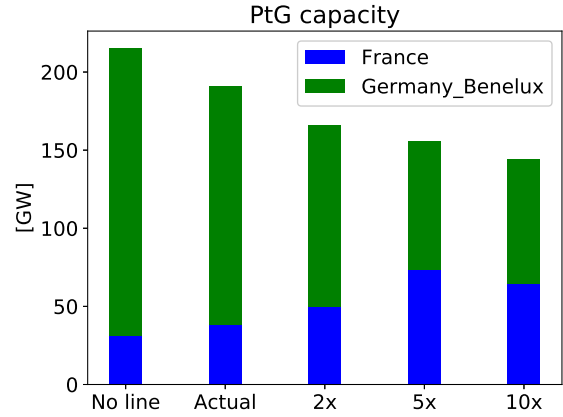

Figure 4.15: PtG installed power in function of the exchange capacity in Germany & Benelux and France.

other cases is observed for the batteries (Figure 4.14). However, if the cost of the batteries is increased by one percent in one of the two cells, all the batteries are placed in the other cell. The distribution of the batteries between the cells in the case 10x the line has an unstable behaviour because it is close to the case with an infinite line, for which it is identical for the system to place the batteries in one cell or in the other.

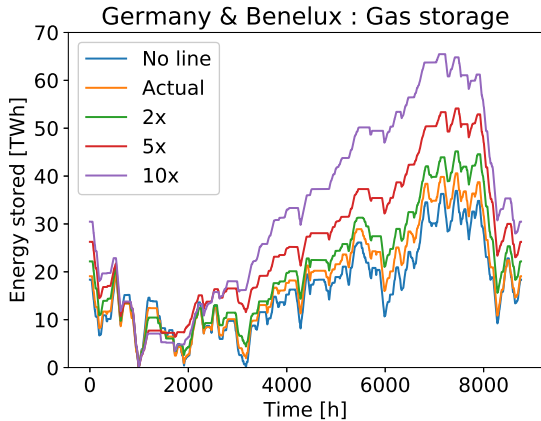

Figure 4.16: Gas storage in function of time and of the line capacity in Germany & Benelux.

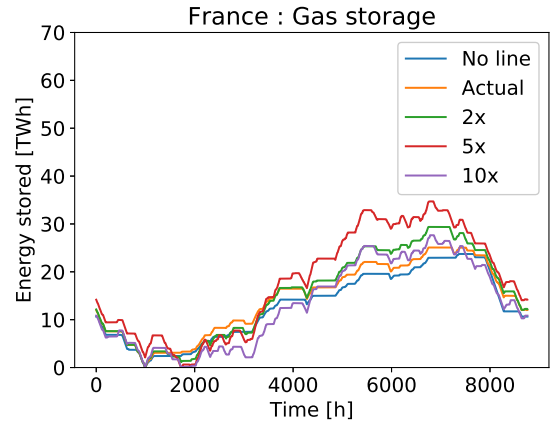

Figure 4.17: Gas storage in function of time and of the line capacity in France.

In Figures 4.16 and 4.17, the energy stored in the gas storage throughout the year for the different scenarios is represented. With no transmission lines, the two cells present a seasonal gas storage but for distinct reasons: France due to its consumption profile and Germany & Benelux due to its important PV production.

The capacity of the gas storage is rather constant in France, since it is linked to its consumption profile which does not change with the line capacity. On the other hand, gas storage increases significantly in Germany & Benelux due to the increase of its consumption of solar production. It is interesting to notice that gas storage in France decreases from 5x to 10x the line capacity due to the important increase of batteries in France.

4.3 Conclusion

Several important conclusions can be drawn from this two-cell study.

First of all, the aim of this study was to apply our model to a new study case comprising the new features of the tool (run-of-the-river and dam as well as coal production for the study presented in Section D.3) and for a bigger area in order to calibrate the model and to fully understand its behaviour with a simple case. It can be concluded that our model delivers coherent results for the two-cell analysis. Indeed, important but realistic RE assets and important but not disproportionate storage assets are obtained for the 100% RE analysis. The production mix obtained is coherent with the meteorological characteristics and potentials of the cells. Moreover, the storage utilisation are meeting the expectations: short-term storage for batteries, mid-term for PHES and long-term for gas storage. This confirms the inputs of the model for the load factors of PV panels and WTs as well as for the costs and parameters of the storage.

Secondly, storage plays a key role in a 100% RE energy system with more than 40% of the energy production stored before consumption. It is observed that the storage mix installed in each cell depends on the production mix and characteristics of the cell. Moreover, the three storage types are used in a complementary way. In the case of France, the CCGT installed power is a limit for the installation of gas storage.

No curtailment is observed in the system. Indeed, the battery storage being sized based on an energy need leads to an important power capacity. Combining both PtG and batteries, all peaks of production can be absorbed.

In the two different studies, it is underlined that the RE assets of each cell depend on the EROI of the technologies but also on the absorption of the production by the system. It is for example observed that France only presents a significant solar production share when well-connected to a cell that efficiently absorbs it, like Germany & Benelux. Looking at the monthly production, the seasonality of WTs and PV panels is noticed. The first presents a lack of production during the summer and the second an increase of production at that period. The complementarity of both productions is used by Germany & Benelux.

Finally, it is observed that the exchanges between the cells influence the RE and storage assets and are limited by the transmission capacity. Indeed, the exchanges allow to place the RE assets in the cell with the best production characteristics and to smooth variations between production and demand. The global energy invested in both RE and storage assets thus lowers with the increase of the line capacity, improving the net EROI of the system. From no line to 10x the actual line capacity, the energy invested in the RE assets decreases by 3.5% and in the storage by 11%. The important decrease of the energy invested in the storage is explained by a net increase of the direct consumption. However, because the RE assets lies for 80% of the total investment, the total energy invested decreases only by 4.5% and this without taking into account the energy invested in order to increase the line capacity.

Chapter 5

Six-cell analysis: Western Europe

In this chapter, the Western Europe electricity system described in Chapter 3 composed of six cells is analysed using the tool developed. First, a 100% RE scenario is studied. The main objectives are to analyse how the production is distributed between the cells and between the different assets, how storage is used as well as how the energy is exchanged into the system to reach the solution with the least energy invested. Second, the system with the doubled exchange capacities is studied. The goal is to determine the impact of the interconnection on the energy cost and to analyse how cells interact with a better transmission.

All the inputs of the model are detailed in Chapter 3. As a reminder, the area, population and electricity consumption and production of each cell is presented in Table 5.1. The period of study is one year with a time step of four hours in order to have an acceptable running time. It was observed with the two-cell model that the solutions for a time step of four hours or of one hour present a variation of the energy invested lower than 0.5%.

Table 5.1: Area, population and annual electricity consumption and production of the cells [48–62].

Cell	Area [km ²]	Population [millions]	Annual elec. consumption [TWh]
Scandinavia	876 000	21	303
British Isles	315 000	70	370
Germany & Benelux	432 000	112	724
France	644 000	69	479
Italy and Alpine states	427 000	78	452
Iberian Peninsula	598 000	57	302

5.1 Study 1: 100% RE electricity system

In the present section, the optimal solution of the 100% RE six-cell model of Western Europe electricity system is analysed. No external import is allowed, the six cells are thus studied as a closed system. The study is made with the actual exchange capacities. First, the energy investment is analysed. Second, a global analysis of the annual productions and exchanges is conducted. Third, the global annual energy flow of the system is detailed. Then, the RE and storage assets of each cell are presented and explained. Finally, the imports and exports of the cells are studied.

5.1.1 Energy investment

Table 5.2 summarises the energy investment and compares it with the 100% RE two-cell model of Germany & Benelux and France with the actual line capacity presented in the previous chapter.

The total annual consumption of Western Europe is 2 630 TWh compared to 1 203 TWh for Germany & Benelux and France. The total energy investment for the Western Europe system is 265 TWh leading to a net EROI of 9.9, compared to 152 TWh and an EROI of 7.9 for the two-cell system. One can notice that even if the consumption is doubled from the two-cell to the six-cell system, the energies invested for the storage are close. As said in Section 4.1, from the energy invested in the storage for the two-cell model, 10 TWh come from Germany & Benelux and 17 TWh from France. For the six-cell model, 7 TWh come from Germany & Benelux and 7 TWh from France. Even if the energy invested in the storage lowers for Germany & Benelux and France, they represent 70% of the energy investment of the storage. Indeed, Germany & Benelux has the highest consumption of the system and thus higher storage needs while France has an intensive use of batteries as detailed later in this chapter. From the 30 TWh invested in the storage for the Western Europe model, 86% lies in the batteries, 13.5% in the PtG and the rest in the gas storage and PHES. The important cost of the batteries and the negligible cost of the gas storage is again highlighted.

Table 5.2: Energy investment of the six-cell and two-cell electricity systems.

	Six-cell	Two-cell
	[TWh]	[TWh]
RE assets	235	125
Storage assets	30	27
Total	265	152

5.1.2 Production and annual exchanges

Figure 5.1 resumes the production and the annual exchanges between the different cells.

Different production mixes can be highlighted from Figure 5.1. The southern cells (Italy and Alpine states and Iberian Peninsula) have high shares of PV production and due to the low load factor of the offshore WTs, only onshore WTs are installed. The central cells (France and Germany & Benelux) base their production mainly on offshore WTs. The rest of the production is covered by a mix of onshore WTs and PV. Finally, the northern cells (British Isles and Scandinavia) mainly base their production on onshore WTs with smaller shares of offshore WTs production. The high hydroelectric production of the mountainous cells (Italy and Alpine states and Scandinavia) has to be underlined. It represents 60% of the production for Scandinavia and 20% for Italy and Alpine states.

It is interesting to note that all the lines are used at their maximum potential. Indeed, they all present a utilisation factor higher than 97%, as detailed in Section 5.1.6. The actual line capacities limit thus the electricity exchanges between the cells. All cells are net exporters on an annual timescale, except Germany & Benelux which is a net importer. The net import of Germany & Benelux represents almost 10% of its energy needs. France is the biggest exporter with a net export of 48.9 TWh towards Germany & Benelux which represents 8.4% of its production but is also the cross point of the system. Energy flows from British Isles and Iberian Peninsula to France to reach Germany & Benelux. Only 20% of the energy entering France is to be consumed within the cell. Italy and Alpine states is also used as a cross node to reach Germany & Benelux. Indeed, from the 33.2 TWh transferred from Italy and Alpine states to Germany & Benelux, only 15% comes from the production of Italy and Alpine states. One can also notice that even if the energy flows notably more in one direction (towards Germany & Benelux), the transmission lines are used in the two directions. The exporting cells import thus energy as well. Even if cells act as exporters or importers on an annual basis, exports and imports take place at lower time scales between cells. This is detailed in Section 5.1.6.

In Table 5.3, one can observe the ratio of the annual production to the annual consumption of each cell. All cells produce more energy than their consumption, which leads to a total production

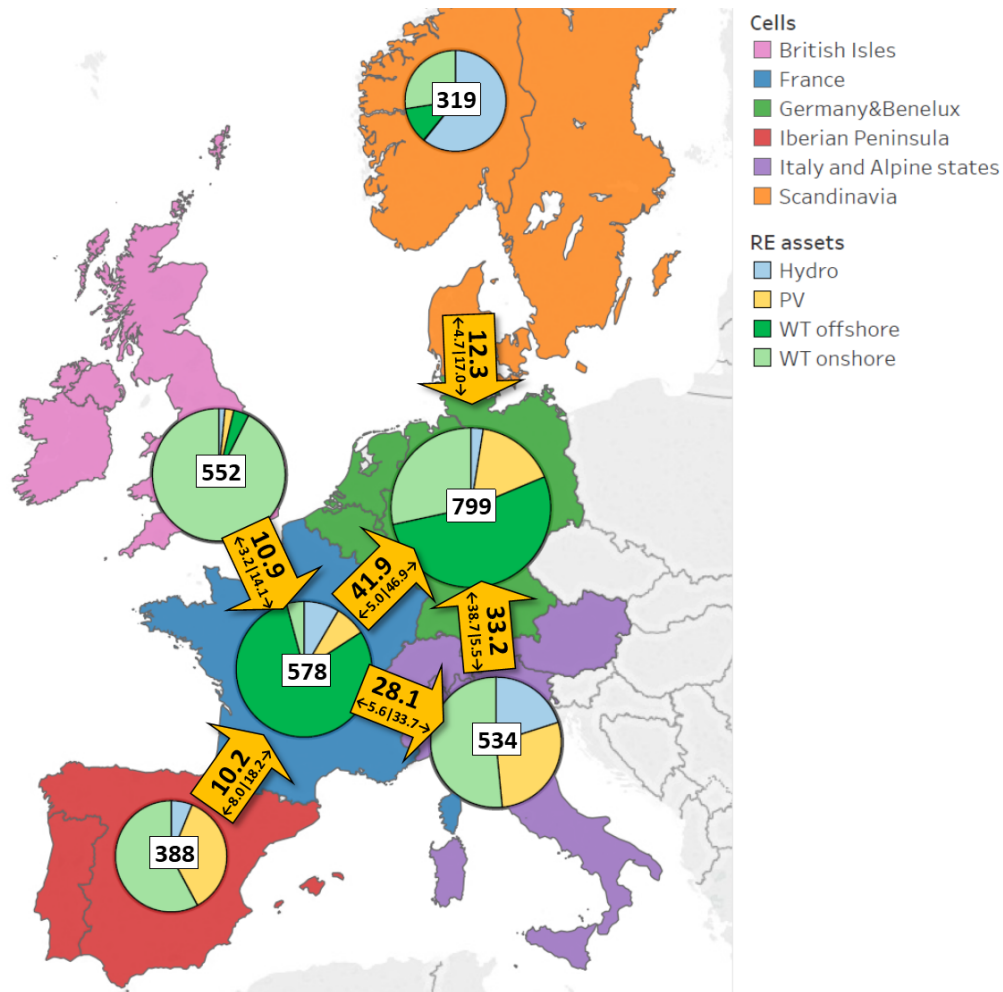

Figure 5.1: Productions and annual exchanges in TWh. Yellow arrows represent net exchanges and sub-arrows represent import and export.

1.2 times higher than the consumption due to the storage losses. Moreover, one can observe the high overproduction of British Isles and the low value of its exports, reflecting important storage losses. On the contrary, Scandinavia presents a production close to its consumption, reporting low storage losses. Regarding Germany & Benelux, even with imports from all its neighbours, its production still exceeds its consumption by 10%.

Table 5.3: Annual production normalised with respect to consumption, net import and export value and share based on the values presented in Figure 5.1. Export share is defined as $\text{Export}/\text{production}$ and import share is defined as $\text{Import}/(\text{Production} + \text{Import})$.

Exporting cells	Production/ Consumption	Net Export [TWh]	Export share
Scandinavia	105.2%	12.3	3.9%
British Isles	149.4%	10.9	2.0%
France	120.7%	48.9	8.4%
Italy and Alpine states	118.1%	5.1	1.0%
Iberian Peninsula	128.5%	10.2	2.6%
Importing cells	Production/ Consumption	Net Import [TWh]	Import share
Germany & Benelux	110.4%	87.4	9.9%

5.1.3 Energy flows

Figure 5.2 resumes the annual energy flow at the scale of the system. It highlights the part of production directly consumed and entering the storage as well as the storage mix.

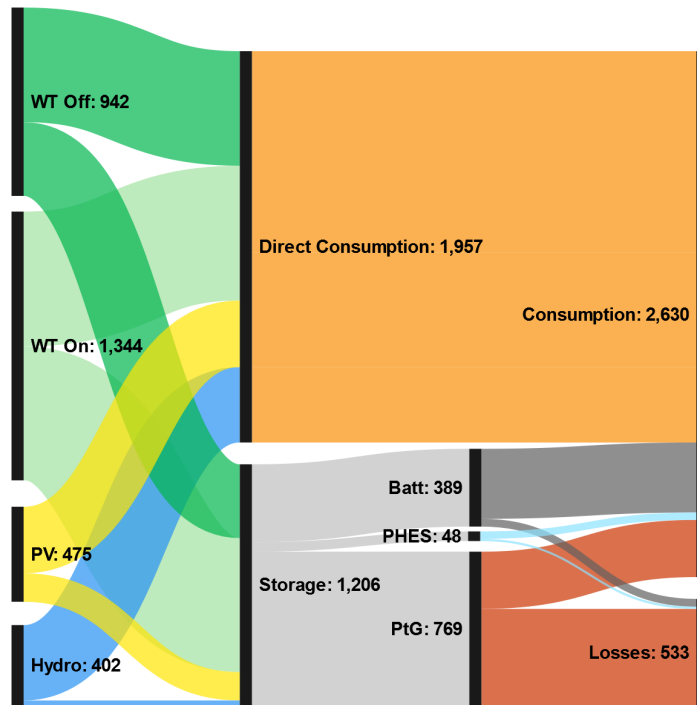

Figure 5.2: Sankey diagram of Western Europe annual energy flow [TWh].

The total production is composed of 42% of onshore wind, 30% of offshore wind, 15% of solar and 13% of hydroelectric production. From this total, 62% is directly consumed and 38% is stored before its consumption. In comparison, for the two-cell model, 43% of the production passed through the storage before being consumed. From the total energy stored, 64% is stored in the gas storage, 32% in the batteries and 4% in the PHEs. The storage losses represent 17% of the production. Table 5.4 details the utilisation of the different means of production. As for the two-cell model, the solar production presents a high percentage of direct consumption thanks to its day/night synchronisation with the consumption and is stored equally in batteries and PtG. Comparing the utilisation of the onshore and offshore WTs, one notices that the second one is better absorbed by the consumption thanks to its better load factor as explained in Section 4.1.4. Looking at wind production, more energy is stored in the PtG than in the batteries, due to its mid-term variations. Finally, 91% of the hydroelectric production is directly consumed, explained by the flexible behaviour of the dams and their important share compared to the run-of-the-river (93% of hydroelectric production from dams).

One can note from Figure 5.2 that no curtailment is observed. As for the two-cell analysis, battery power combined with the PtG are able to absorb all the production peaks leading to an absence of curtailment.

No exchanges are represented in Figure 5.2. However, 4% of the total energy produced is exchanged between the different cells. Still, this value is low compared to the total production. Thus, with the actual interconnections, most of the energy produced in a cell is consumed in that cell.

Table 5.4: Utilisation of the RE assets.

RE asset	Direct consump. [%]	Batteries [%]	PtG [%]	PHEs [%]
PV	70	13	15	2
WT onshore	50	11	37	2
WT offshore	61	18	20	1
Hydro	94	2	3	1

5.1.4 RE assets

In this section, an overview of the installed RE assets is given. A summary of the results of the RE and storage assets is presented in Table E.1.

Figure 5.3 displays the RE assets of the 100% RE system. The upper and lower limits are represented. In order to understand the behaviour of the system, EROI values of the different RE assets are reminded in Table 5.5.

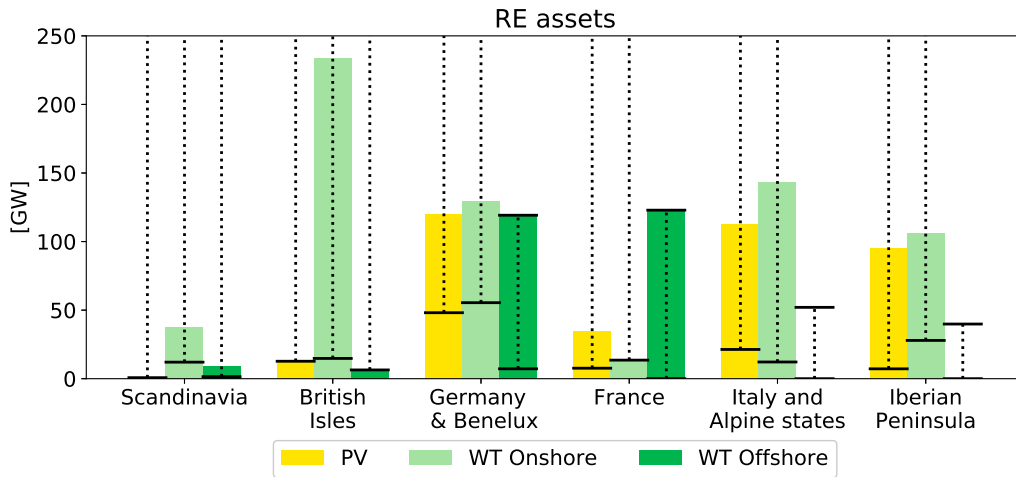

Figure 5.3: Installed RE capacity of the different cells. The horizontal black lines correspond to the upper and lower limits and the dotted lines to the domain of solutions.

Table 5.5: Gross EROI of the RE assets.

Cell	WT Onshore	WT Offshore	PV
Scandinavia	15.6	12.8	6.1
British Isles	14.6	10.2	6.6
Germany & Benelux	11.7	11.1	7.6
France	11.8	11.8	8.6
Italy and Alpine states	12.8	9.1	9.4
Iberian Peninsula	14.3	10.6	10.3

Table 5.6 compares the installed RE capacity with the mean power consumption of each cell. It highlights the high RE installed capacity with respect to the consumption. During peaks of production, WTs reach their rated power and the production corresponds to the installed capacity. On the other hand, PV panels will not necessarily reach their installed capacity during peaks of production. Indeed, the capacity is expressed in W_p , corresponding to the power produced when PV panels are exposed to an irradiance of 1000 W/m^2 . This irradiance is never reached in the

cells, the maximums observed are between 850 and 950 W/m².

Table 5.6: Ratio of the installed RE capacity to the mean consumption.

Cell	WT onshore	WT offshore	PV
Scandinavia	1.09	0.26	0.02
British Isles	5.54	0.15	0.30
Germany Benelux	1.57	1.44	1.45
France	0.25	2.25	0.64
Italy and Alpine states	2.78	0	2.19
Iberian Peninsula	3.08	0	2.75

As demonstrated in the previous chapter, the two factors determining the RE assets installed are their EROIs and their absorption by the consumption. As presented in the two-cell study, the production profiles being similar for each RE assets across Western Europe (see Section 3.3), a similar absorption by the consumption for a given cell is observed if its production is located in that cell or in another cell. The system tends thus to install each RE assets in the cells presenting the best EROI but is limited by the exchange capacity of the lines. From Table 5.5, it is noticeable that Germany & Benelux presents the lowest PV EROI among the cells installing PV and the lowest EROI for onshore WTs. PV panels are therefore installed in France, Italy and Alpine states and Iberian Peninsula and WTs are installed in all the cells to supply Germany & Benelux.

Scandinavia has an important hydroelectric production which represents 60% of its total production, explaining why it installs far less RE assets than other cells. However, it presents the best EROI both for onshore and offshore WTs and still has a large potential. Its wind production is under-exploited due to its low needs and to its poor interconnection with the rest of the system. The major part of the WT capacity is onshore which is directly linked to its high EROI and no PV panels are installed because of the weak irradiance.

In British Isles, only onshore WTs are installed. Indeed, PV panels present a low EROI and the fact that no offshore WTs are installed comes from the important gap between onshore and offshore EROI. As detailed in Section 3.3.3, a better offshore load factor could be expected for this cell which would promote a higher use of offshore WTs. The onshore WTs installed capacity is 230 GW, which represents more than five times its mean consumption. Important storage capacities will then be needed in order to be able to store the production when the WTs reach their nominal power.

Germany & Benelux and France present a distribution of their RE assets close to two-cell 100% RE study with the actual line capacity (Section 4.1). Both cells reach their upper limit of offshore WTs which corresponds to approximately 120 GW. Germany & Benelux has an equilibrated mix with the three technologies installed. In addition to the offshore WTs, France only installs a small amount of PV panels. As pointed in the section referenced hereabove, if France is disconnected from all other cells, it only installs offshore wind WTs. The PV production appears because of its connection with Germany & Benelux.

Iberian Peninsula and Italy and Alpine states have a similar behaviour, installing only onshore WTs and PV panels. These are the two cells with the highest PV shares thanks to their high EROI for this asset. As for British Isles, no offshore WTs is installed due to its poor EROI compared to onshore. It has to be noticed that, in both cells, the installed capacity of WTs is approximately three times bigger than the mean consumption and two times bigger for the PV panels.

Table 5.7 presents the number of inhabitants per WT (no distinction between onshore and offshore), the surface of PV panels per inhabitant, the land-use of the RE assets in percent of the inland area of the cell as well as the population density of each cell to put into perspective these

results. In order to compute the values presented, the capacity density of the WTs ($\rho_{PWT,j,c}$) is fixed to 4 MW/km² as explained in Section 3.3.3 and the factor of net PV surface in comparison with the necessary surface of the installation ($\alpha_{PV,j,c}$) is equal to 5 as introduced in Section 3.3.4. For the results presented, the offshore WTs are considered as if they were on the inland territory.

Table 5.7: RE assets put into perspective.

Cell	WT [hab/5MW _{eq}]	PV panels [m ² /inhab.]	Area used [%]	Population density [Inhab./km ²]
Scandinavia	2249	0.4	1.4	24
British Isles	1458	1.8	20.2	222
Germany & Benelux	2251	10.7	15.7	259
France	2528	5.1	6.4	107
Italy & Alpine states	2716	14.5	9.7	180
Iberian Peninsula	2682	16.7	5.2	98

From Table 5.7, it can be underlined that the percentage of used area is linked to the population density of the cell. Indeed, consumption is closely related to the number of inhabitants. The cell with the highest area utilisation is British Isles, with the equivalent of more than 20% of its territory used to install RE assets. Scandinavia shows the lowest RE density thanks to its hydroelectric production. It can be stressed that in the southern cells a higher surface of PV panels per capita is encountered. This value reaches 16.7 m² in Iberian Peninsula. Concerning WTs, British Isles presents the highest density with one WT for 1458 inhabitants.

5.1.5 Storage assets

In this section, the distribution of the storage assets is analysed. First, a general analysis regarding the storage assets is made leading to a classification of the cells into different categories. These categories are then discussed.

Figure 5.4 presents the different storage assets of the 100% RE Western Europe system. As presented in Section 5.1.3, 38% of the total energy produced is stored: 24% in the gas storage, 12% in the batteries and 2% in the PHEs.

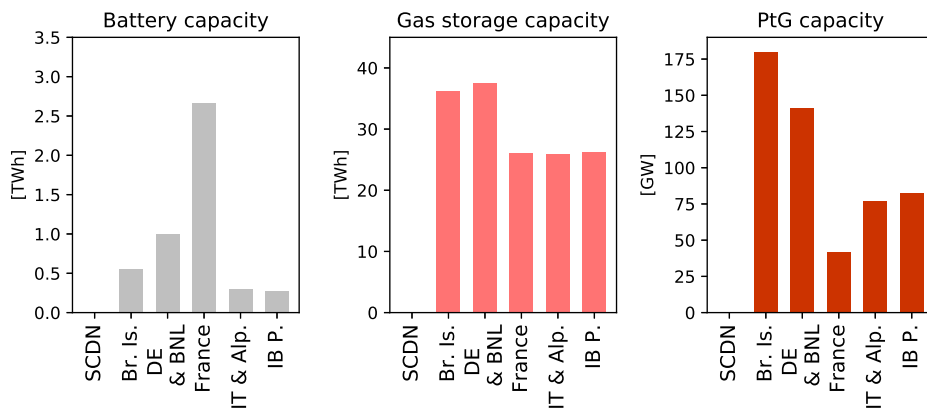

Figure 5.4: Installed storage assets of the different cells.

Three categories of storage mix can be distinguished looking at Figure 5.4. The first storage category is Scandinavia, which installs an insignificant amount of storage. Indeed, only 0.5% of its production is stored. It is then noticeable that all other cells have a gas storage capacity at least forty times higher than their battery capacity, except France whom gas storage capacity is

only ten times higher. The second category is thus France and the third category gathers British Isles, Germany & Benelux, Italy and Alpine states and Iberian Peninsula.

In Table 5.8, the volume of batteries per capita of each cell is presented. Similar to Section 4.1.5 these values are based on the Tesla Powerpack [88]. It can be noticed that cells mainly relying on wind production such as British Isles and Germany & Benelux have a higher volume per capita compared to cells with a stronger PV share such as Italy and Alpine states and Iberian Peninsula. France has the highest volume per capita, more than four times bigger than the other cells.

Table 5.8: Batteries installed capacity and volume of installed batteries per capita.

Cell	Battery capacity [TWh]	Volume per capita [dm ³ /capita]
Scandinavia	0.009	5
British Isles	0.6	95
Germany & Benelux	1.0	99
France	2.7	436
Italy and Alpine States	0.3	43
Iberian Peninsula	0.3	59

Figure 5.5 presents the annual storage inputs per cell in regard to its production.

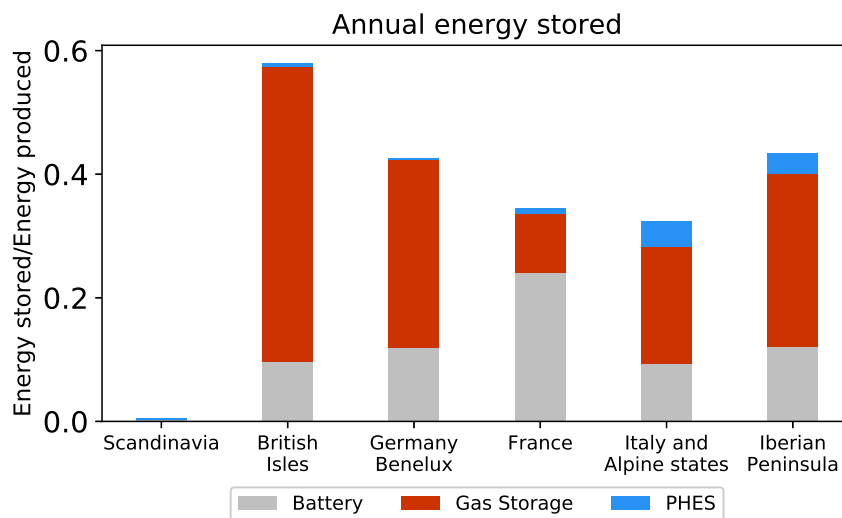

Figure 5.5: Annual storage input per cell.

From Figure 5.5, it is noticeable that all cells (without Scandinavia) present a storage input between 30 and 40% of their total production, except British Isles that has a storage input equal to 55% of its total production. One can also observe that for all cells (without Scandinavia), except France, the battery input represents approximately 10% of the energy produced. This figure reinforces the categories defined here above. Indeed, British Isles, Germany & Benelux, Italy and Alpine states and Iberian Peninsula have an important gas storage share (more than 60% of the energy storage inputs) in comparison with France (27% of the energy storage inputs).

Inside a cell, the utilisation of the different kinds of storage is very different. Looking at Italy and Alpine states for example, one can see that even with a gas storage 85 times bigger than the battery storage, there is still 29% of the energy stored in the batteries against 59% in the gas storage. This shows that batteries are by far more frequently used than PtG. In most of the cells, PHES represents a marginal amount of the energy stored, apart from Italy and Alpine states and

Iberian Peninsula where a bigger PHES capacity compared to the cell production is installed. It represents 12% of the energy stored for Italy and Alpine states and 8% for Iberian Peninsula.

Figure 5.7 presents the number of cycles of the different storage systems for different cycles duration. The method used to determine the number of cycles is similar to the previous study and detailed in Section 4.1.5.

As stated in Section 4.1.5, it is expected for batteries to be used as a short-term, for PHES as a mid-term and for gas storage as a long-term storage. Observing the aforementioned figure, these expectations are globally met. However, due to the low installed capacity of the PHES, the mid-term storage needs are mainly covered by the gas storage in all cells, except France for which it is covered by the batteries.

Looking at the number cycles of batteries in Italy and Alpine states and Iberian Peninsula, it appears that the major part occurs in one day or less. This number is by far larger than for the other cells. This clearly shows the link between a high PV share system and a day/night battery storage. On the other side, looking at the PtG cycles of British Isles and Germany & Benelux, the major part of the cycles occur within two days to one week. The production of these cells strongly relies on WTs production which can drop under less than 25% of the consumption of the cell during up to 9 days in Germany & Benelux and 7 days in British Isles. This can represent a deficit of more than 6 TWh in British Isles. Battery storage is therefore not adequate to face such energy needs. The third category is thus split into two: British Isles and Germany & Benelux with an important wind share inducing a high mid-term utilisation of the gas storage and Italy and Alpine states and Iberian Peninsula with an important solar share leading to a high number of short-term cycles of the batteries.

From Figure 5.7, it is also noticeable that France has a rather low number of cycles of the batteries with a bigger utilisation in a time range of 48h to one week. France tends to use its batteries as a weekly storage to store power during high wind periods and discharge power during low wind weeks.

Figure 5.6 presents the normalised evolution of the gas storage of each cell. The gas storage of Scandinavia, being three orders of magnitude lower than the others, is not represented. Even if gas storage is sometimes used as mid-term storage, it still displays a seasonal utilisation in each cell. It is interesting to see that all the curves follow the same trend, filling the storage in spring and starting to discharge gas in the CCGT in autumn, except British Isles. British Isles reaches its maximum storage in May and starts to discharge it in the middle of spring season. This behaviour is detailed hereafter.

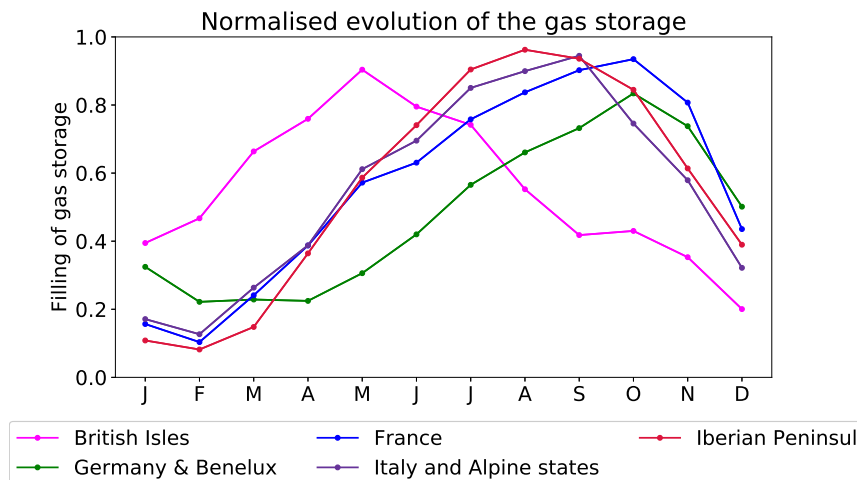

Figure 5.6: Normalised monthly evolution of the gas storage of each cell (without Scandinavia), based on the content of the last day of the month.

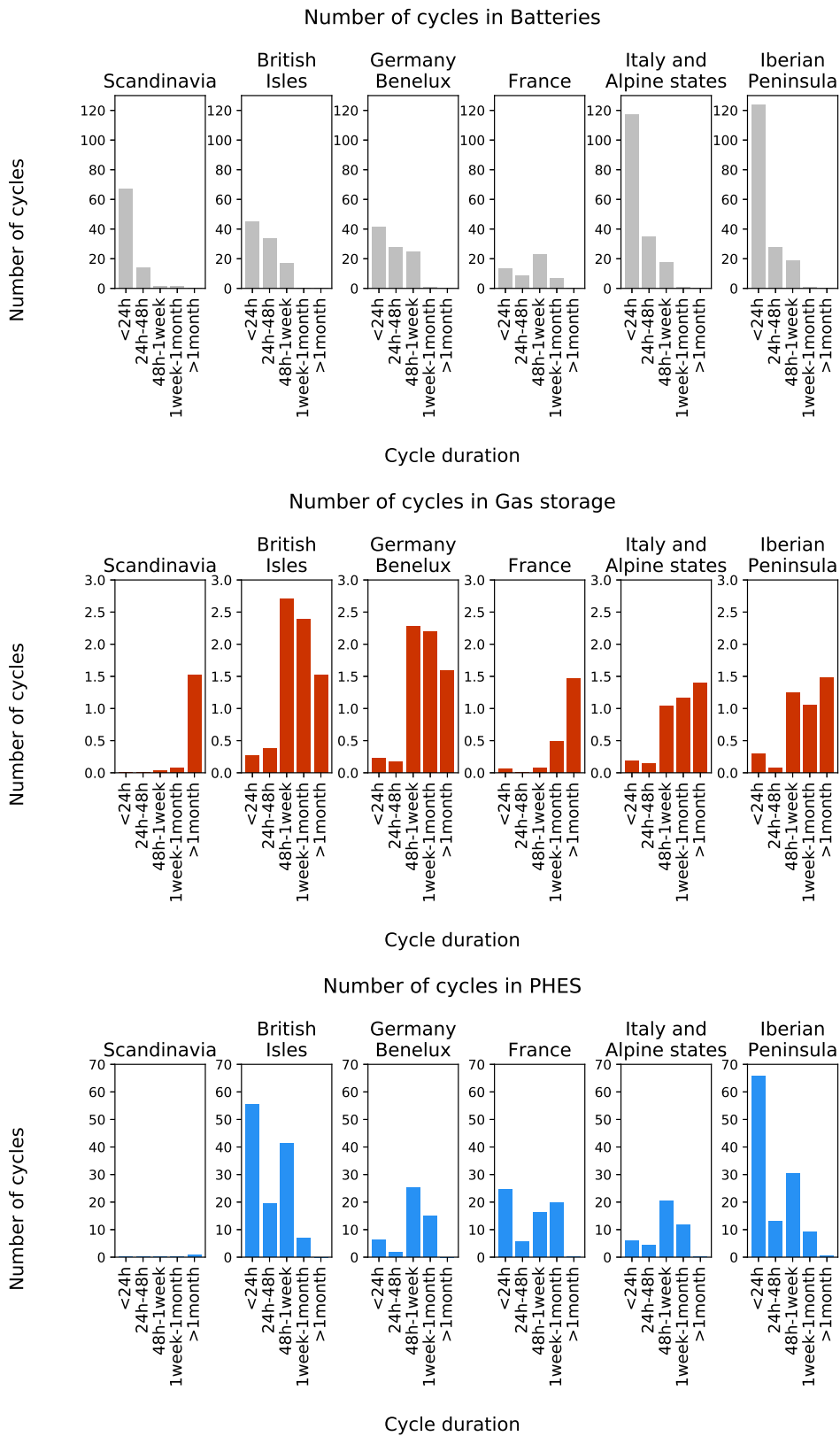

Figure 5.7: Number of cycles in batteries, gas storage and PHES per cell.

In the following subsections, the four categories highlighted thanks to the analysis of the storage assets, the annual energy stored and the number of cycles of each storage systems are detailed.

No storage: Scandinavia

Figure 5.8 displays the monthly production, consumption, net storage variation and net exchange of Scandinavia. As a reminder, the positive bars correspond to the total monthly production, net output of storage and net import of the cell. The negative bars correspond to net input of storage and net export. The difference between positive and negative bars corresponds thus to the monthly consumption, storage losses and curtailment (no curtailment here). Similar figures are presented in this section for several cells but, for a better visualisation, the scales are different. It can be observed that Scandinavia consumption has a strong seasonal behaviour. This is due to the intensive use of electrical heating systems, particularly in Norway [80]. As already mentioned, hydroelectric production represents 60% of the production of the cell and is nearly entirely composed of dams (99.9%). The flexible behaviour of dams allows to adapt the production to the seasonality character of the consumption and of WT production but also to overcome the short-term variations of these two. Only 9.6 GWh of battery are installed which are occasionally used in case of short-term peaks of wind production to store the energy surplus, as well as a PtG of 70 MW and a gas storage of 62 GWh used to store WT mid-term energy surplus.

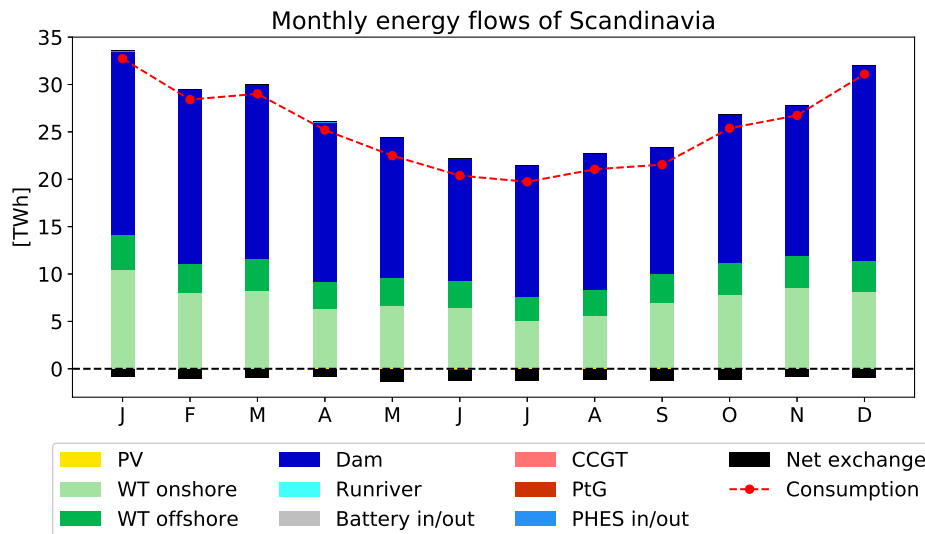

Figure 5.8: Scandinavia monthly energy flows. Net exchange corresponds to the net import (>0) or net export (<0) of a cell.

Battery based storage: France

Figure 5.9 displays the monthly energy flows of France. As presented in Section 4, France presents a strong seasonal variation of consumption.

The seasonal behaviour of the French wind production is again noticed. However, this production follows the consumption seasonality which allows to lower the long-term storage needs.

As for the other cells with an important wind production share, France storage cycles are mainly between 48 hours and one week. However, as illustrated in Figure 5.7, these are achieved by the batteries in France and by the gas storage in the other cells. Furthermore, Figure 5.9

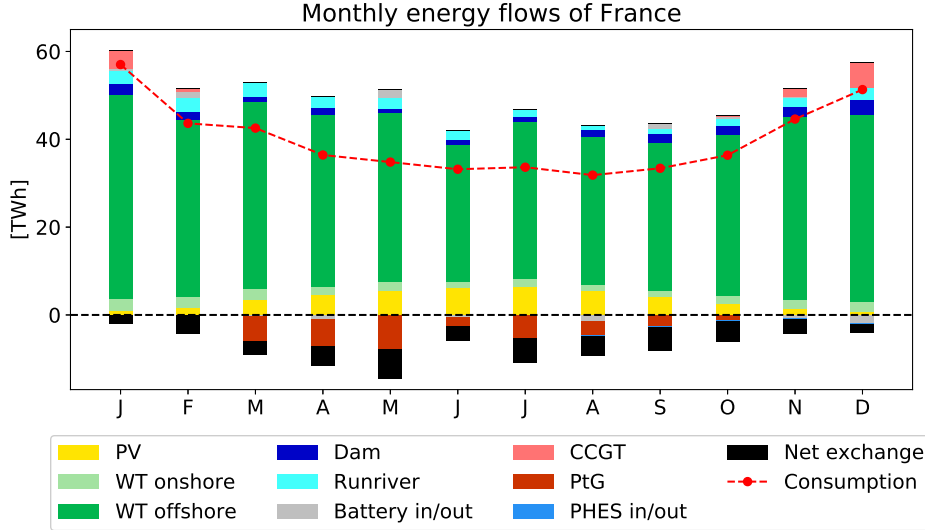

Figure 5.9: France monthly energy flows. Net exchange corresponds to the net import (>0) or net export (<0) of a cell.

shows that battery storage sometimes has a noticeable net variation over the month as can be seen in December and May. Table 5.9 presents the CCGT installed capacity per cell in function of the average consumption. As it was already observed in the two-cell model, France has a CCGT installed power much lower in comparison with its average power consumption than the cells with a gas-based storage. Its CCGT is thus not able to overcome the power needs faced during wind drops and batteries are needed. Its low CCGT power in comparison with the rest of Western Europe is due to its actual important nuclear production which represents more than 70% of its production and that is not gathered in the category "CCGT" of the model. The fact that batteries execute mid-term storage induces a high power oversizing as presented in the analysis of the two-cell model.

Table 5.9: Ratio of CCGT installed power to the average power consumption.

Cell	CCGT power / Average consumption
Scandinavia	0.4
British Isles	1.0
Germany & Benelux	0.9
France	0.3
Italy and Alpine states	1.1
Iberian Peninsula	1.1

To confirm the hypothesis of the low CCGT power in France in comparison with its average consumption which explains the storage mix of France, a case similar to the one studied but with the CCGT capacity of France multiplied by three has been studied. In that case, France has the same ratio of CCGT power to average consumption than the other cells. This experience showed that, with a higher CCGT, France presents indeed a storage mix similar to the other cells: from the total energy stored, two thirds is stored in the gas storage and one third in the batteries. The increase of CCGT induces a strong decrease of the batteries (from 2.7 TWh to 0.5 TWh) and an increase in PtG capacity (from 41 GW to 78 GW). Looking at the system, it leads to a decrease of the total energy invested in the storage and an increase of the energy invested in

RE assets due to the higher losses of the gas storage. Altogether, it allows to reduce the Total energy investment of 1.2%, reaching a global EROI of 10.04 compared to 9.91 previously.

Gas-based storage with high wind share: British Isles and Germany & Benelux

In Figure 5.10, the monthly energy flows of British Isles are represented. As in Scandinavia and in France, wind production presents a strong seasonality. Due to the extremely high wind production share (97%), this seasonal variation has a direct effect on the total production profile of the cell. This seasonality is in phase with the consumption, which increases in winter and decreases in summer. However, wind production drops significantly during summer, leading to a lack of production. This long-term shortage (from June to September) is overcome using the gas storage and reducing the exports.

As mentioned earlier, Figure 5.6 illustrates that British Isles presents a gas storage use shifted compared to other cells. Indeed, as can be seen in Figure 5.10, it fills its gas storage during the month of high wind production (from January to May) and empties it the rest of the year. On the other hand, the overproduction of all the other cells takes place during summer, either due to the increase of solar production (Germany & Benelux, Italy and Alpine states, Iberian Peninsula) or due to the decrease of the consumption (France). Thus, they fill their gas storage from April to September. Moreover, British Isles produces 50% more than its consumption as presented in Table 5.3. This huge gap is due to the high losses of the gas storage.

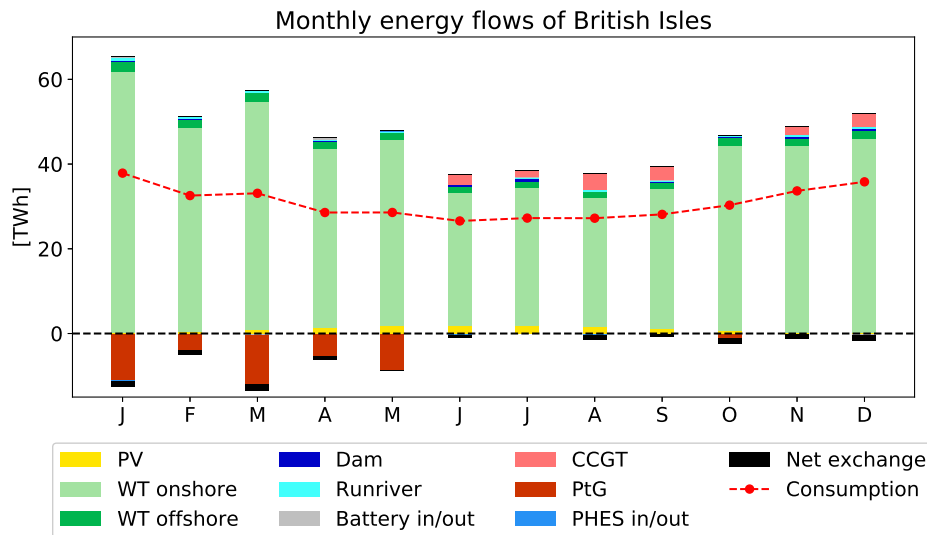

Figure 5.10: British Isles monthly energy flows. Net exchange corresponds to the net import (>0) or net export (<0) of a cell.

The monthly energy flows of Germany & Benelux are displayed in Figure 5.11. The seasonality of the wind production is once again noticed. The production of Germany & Benelux, as British Isles, is clearly dominated by wind production (81% of the production) but has a more significant solar production. As for the two-cell analysis, the complementarity of the wind and solar production is clearly observed. The lower of the wind production during the summer is nearly completely compensated by the increase of the production of the PV panels, which allows to lower the long-term storage needs. Indeed, the ratio of the gas storage capacity to the annual consumption of Germany & Benelux is two times smaller than the one of British Isles.

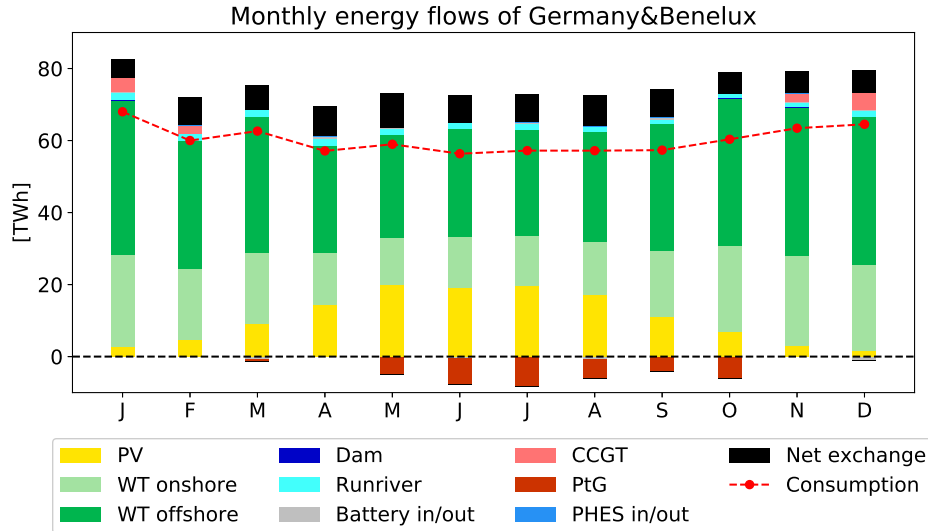

Figure 5.11: Germany & Benelux monthly energy flows. Net exchange corresponds to the net import (>0) or net export (<0) of a cell.

Gas-based storage with high PV share: Italy and Alpine states and Iberian Peninsula

Figure 5.12 presents the monthly energy flows of Iberian Peninsula. The profile of Italy and Alpine states is not detailed due to its similarities with to the one presented. Still, it can be found in Appendix E.

The consumption profile of the southern cells presents an increase during the summer due to the use of air conditioning systems [14]. For these cells, the need of long-term storage is due to the seasonal variation of solar production. The gas storage is filled during the summer months and emptied during winter. The high solar share leads also to an important number of short-term cycles of the batteries as presented in Figure 5.7. These cycles correspond to the day/night charges and discharges of the batteries due to the daily profile of the solar production.

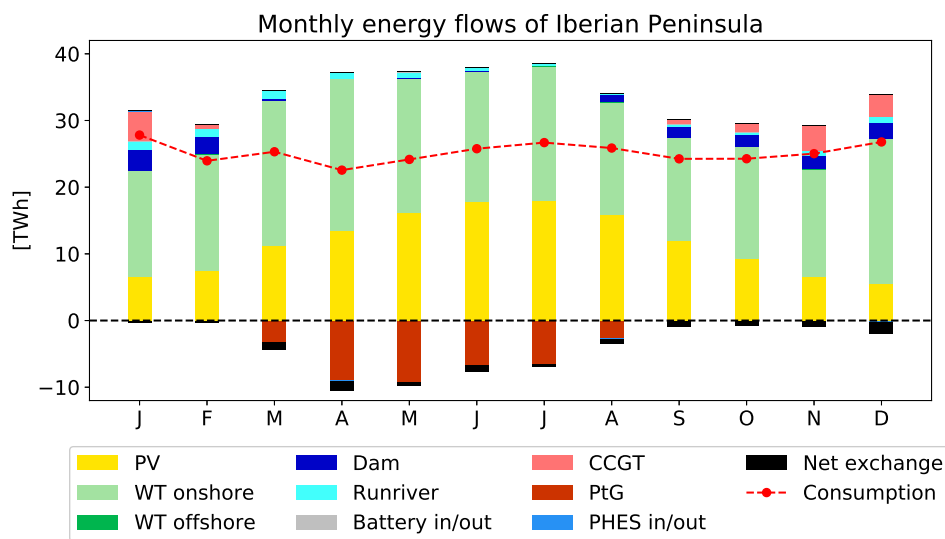

Figure 5.12: Iberian Peninsula monthly energy flows. Net exchange corresponds to the net import (>0) or net export (<0) of a cell.

5.1.6 Electricity exchanges

In this section, the annual exchanges presented in Figure 5.1 are detailed. First, the interconnections of the cells and the utilisation of the transmission lines are analysed. Then, the monthly exchanges between cells are studied to understand how electricity exports and imports are used to lower the energy investment.

As said earlier, only 4% of the total energy produced is exchanged between the cells before being consumed. Looking at the level of a cell with Table 5.3, one notices that imports and exports play a particularly important role in the energy system of France and Germany & Benelux. France has a net export of 8.4% of its production, while the net import of Germany & Benelux represents 9.9% of its energy needs.

Table 5.10 presents the import and export capacity in function of the average consumption of each cell, highlighting their interconnection level.

Table 5.10: Import and export capacity in function of the average consumption.

Cell	Import capacity/ Average consumption [%]	Export capacity/ Average consumption [%]
Scandinavia	6.2	7.7
British Isles	4.7	4.7
Germany & Benelux	17.3	13.8
France	23.2	30.8
Italy and Alpine states	18.4	14.7
Iberian Peninsula	8.6	9.0

France, Germany & Benelux and Italy and Alpine states present an interconnection noticeably better than the other cells. These three cells have indeed multiples connections while the others are only connected to one neighbouring cell. Moreover, it is interesting to note that, regarding the actual connections, France presents an export capacity noticeably greater than its import capacity, due to its strong nuclear power [10]. The very low interconnection of British Isles with the rest of the system is also highlighted.

Table 5.11 resumes the utilisation factor of the transmission lines.

Table 5.11: Utilisation factor of the transmission lines.

Line	Utilisation factor [%]
Scandinavia ↔ Germany & Benelux	97
British Isles ↔ France	99
Germany & Benelux ↔ France	97
Germany & Benelux ↔ Italy and Alpine states	97
France ↔ Italy and Alpine states	98
France ↔ Iberian Peninsula	98

All the transmission lines present a utilisation factor higher than 97%. The capacity of the lines is thus clearly limiting the exchanges. The impact of an increase of this parameter is studied in Section 5.2. If imports and exports play a more important role in France and Germany & Benelux, it is therefore because more exchanges are possible. However, Italy and Alpine states has a good interconnection and its lines are highly used, as seen in Table 5.11, but its net export represents only 1% of its production. It is because only 40% of the energy passing through the lines connecting Italy and Alpine states involves this cell. The other 60% are used to transmit

energy from France to Germany & Benelux. Energy flows from France to Germany & Benelux through Italy and Alpine states because the line joining the two cells is already fully congested.

The following subsections present how the electricity exchanges are used to minimise the total energy invested of the system. In order to understand the exchanges between the cells, the provenance of the energy imports and the destination of the exports is determined. The provenance corresponds to the cells where the energy imported is actually produced and the destination corresponds to the cell where the exported energy is consumed.

Exchanges allow to produce in the cells with the best production profiles

Germany & Benelux is the only net importing cell on an annual scale, as highlighted in Table 5.3 and Figure 5.1 but it also exports a part of its production. The monthly imports and exports of Germany & Benelux are displayed in Figure 5.13. One has to note that, in Figure 5.13, Germany & Benelux imports energy from Iberian Peninsula while there is no line connecting the two cells. It corresponds to energy produced in Iberian Peninsula that passes through France (and possibly through Italy and Alpine states as well) to be consumed in Germany & Benelux. Positive and negative values represent energy imports and exports respectively. Similar figures are presented in the following subsections for several cells but, for a better visualisation, the scales are different.

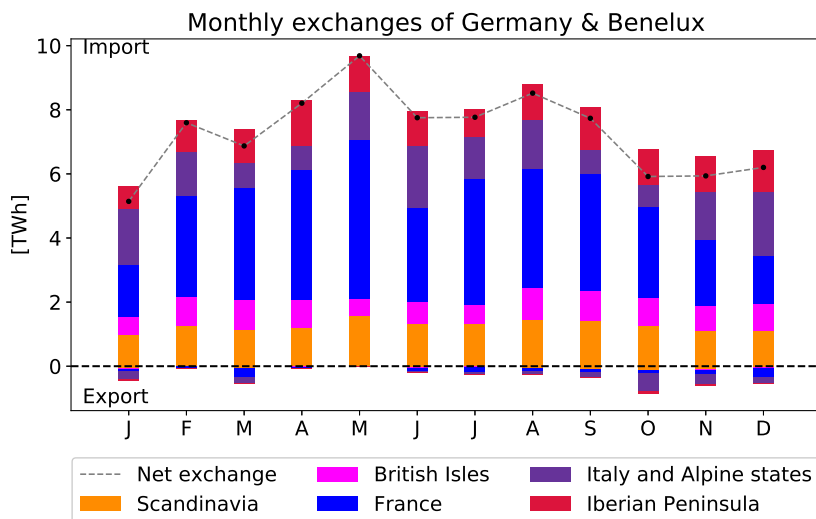

Figure 5.13: Monthly imports (positive) and exports (negative) of Germany & Benelux.

As seen in Figure 5.13, Germany & Benelux has an importing behaviour all year-round. Its exchanges are mainly in one way: it strongly imports but negligibly exports. Its exchanges are thus not made to take advantage of a complementary of its production with the production of other cells but are due to an annual lack of production. Indeed, due to the low EROI of its RE assets, it is energetically more interesting to displace its production in cells with a higher EROI and import from these, as explained in Section 5.1.4. Germany & Benelux imports from all cells but mainly from France explained by the important interconnection and high EROIs of the latter.

A variation of the net import is noticed throughout the year, with a decrease during the months of high wind production (October to January).

Compared to the two-cell scenario in the same case (100% RE with actual exchange capacities), the net import increases in Germany & Benelux with a net import which represents nearly 10% of the total energy needs in the current scenario against 3.8% in the previous one due to the better interconnection of the cell (additional connections with Scandinavia and Italy and Alpine

states).

Exchanges lower the long-term storage needs

As stated in Section 5.1.5, British Isles faces a lack of wind production during the summer which is overcome with the gas storage. Figure 5.14 displays the electricity exchanges of this cell. The fact that the exchanges between cells allow to lower the storage needs is clear. During the months with an important wind production (from October to March), energy is exported with nearly no imports while, during the months with a low wind production, the energy exports lower and the imports increase noticeably. Imports coincide thus with the important decrease of the gas storage (see Figure 5.10), lowering the gas storage capacity and the storage losses. The imports come from France, Italy and Alpine states and Iberian Peninsula which all encounter an increase of their production in respect of their consumption during those months.

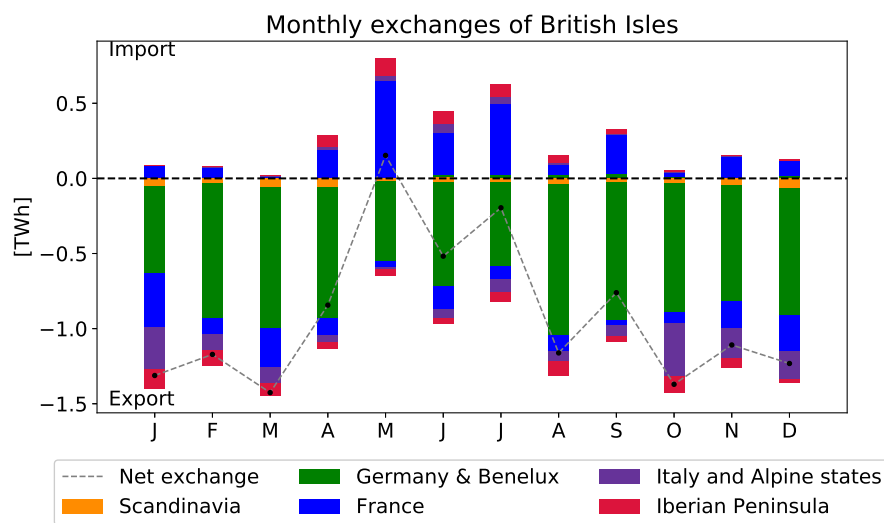

Figure 5.14: Monthly imports (positive) and exports (negative) of British Isles.

A seasonal complementarity between British Isles and the southern cells (Iberian Peninsula and Italy and Alpine states) is observed in Figure 5.14. During the winter, British Isles transfers energy to the southern cells because of its important wind production and the lower solar production of the south. During the summer, the southern cells transfer energy to British Isles thanks to their important solar production to counteract the decrease of the British Isles wind production. However, this effect is weakly observed since, for those cells to exchange, energy has to flow through two or three lines at least and thus lowers the other possible exchanges. The decrease of production of the WTs in British Isles is therefore mainly covered by the production of the PV panels of France.

Exchanges lower the day/night storage needs

Figure 5.15 presents the imports and exports of Iberian Peninsula. Even with a net exporter behaviour, the imports of Iberian Peninsula from France are important. Moreover, during summer, these imports do not lower even if production is highly above consumption, as seen in Figure 5.12. In Figure 5.16, a differentiation is made between the energy exchanged during the night and the day. The day is considered from 8am to 8pm and the night from 8pm to 8am. One notices that throughout all the year the energy is mainly exported during the day and imported during the night. This is explained by the strong difference between its day and night production due to its high solar share (36% of its production). Exporting during the day and importing

during the night lowers the daily energy storage that has to be done by the batteries, lowering their capacity and losses. Imports are thus made all the year to overcome the night needs.

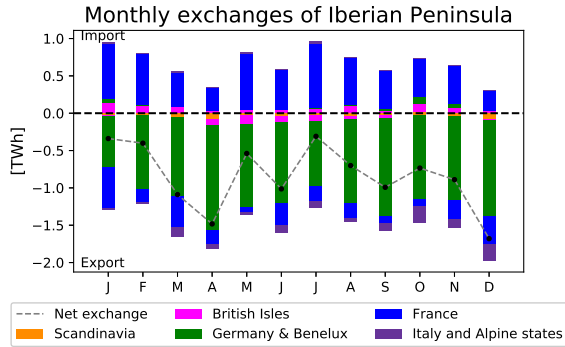

Figure 5.15: Monthly imports (positive) and exports (negative) of Iberian Peninsula.

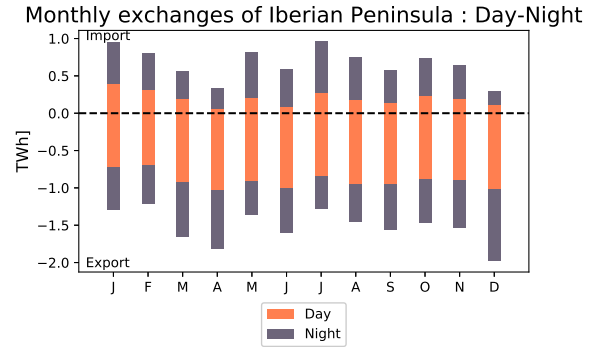

Figure 5.16: Monthly imports and exports of Ib. Penin. with night and day distinction.

5.1.7 EROI analysis

The EROI per cell as well as the global EROI is presented in Table 5.12.

Table 5.12: EROI per cell and global EROI.

	EROI
Scandinavia	35.0
British Isles	8.5
Germany & Benelux	8.9
France	8.0
Italy and Alpine States	11.3
Iberian Peninsula	9.5
Global	9.9

First, looking at France and Germany & Benelux, it can be observed that their EROIs have increased compared to the equivalent two-cell scenario, where their EROIs were equal to 7.79 and 7.95 respectively. This increase comes from a reduction in battery installed capacity for France and higher imports (thus lower assets) for Germany & Benelux.

Scandinavia presents an important EROI compared to other cells. Indeed, hydroelectric production is not considered in the computation of the energy investment. Moreover, since Scandinavia mainly bases its production on hydroelectric, no storage has to be installed.

Southern cells have the second best EROI, after Scandinavia. Thanks to their high PV production share, their storage losses and capacities are reduced.

Germany & Benelux, as an importing cell, shows a higher EROI than France and British Isles. Indeed, as stressed earlier, importing energy allows to decrease its energy investment but increases the investment of the exporting cells.

Finally, France and British Isles have the two lowest EROI. In France, it is due to its high investment in batteries and high exports. In British Isles, it is explained by its intensive use of gas storage generating high losses.

5.2 Study 2: Impact of the exchange capacities

In this section, the impact of the exchange capacities is analysed. The results obtained for the 100% RE Western Europe electricity system presented in the previous section are compared with the ones obtained with the exchange capacities between the cells being doubled. The system with the actual line capacities is referred as "*scenario 1*" and with two times the actual line capacities as "*scenario 2*". First, the energy investment is analysed. Second, the production and net annual exchanges are presented. Third, the energy flows are discussed. Then, the RE and storage assets are studied. Finally, the electricity exchanges are summarised.

5.2.1 Energy investment

Figure 5.17 presents the energy invested per cell and for the global system for scenario 1 and 2. The total energy invested lowers by 2.5% with the increase of the exchange capacities: the investment for the RE assets lowers by 0.6% and the investment for the storage by 17%. This is translated into an increase of the global net EROI from 9.9 to 10.2 as reflected in Table 5.13. A decrease of the energy invested for the RE assets of Germany & Benelux can be pointed while an increase of this value for all the other cells is observed. This reports a transfer of RE assets from Germany & Benelux to the other cells.

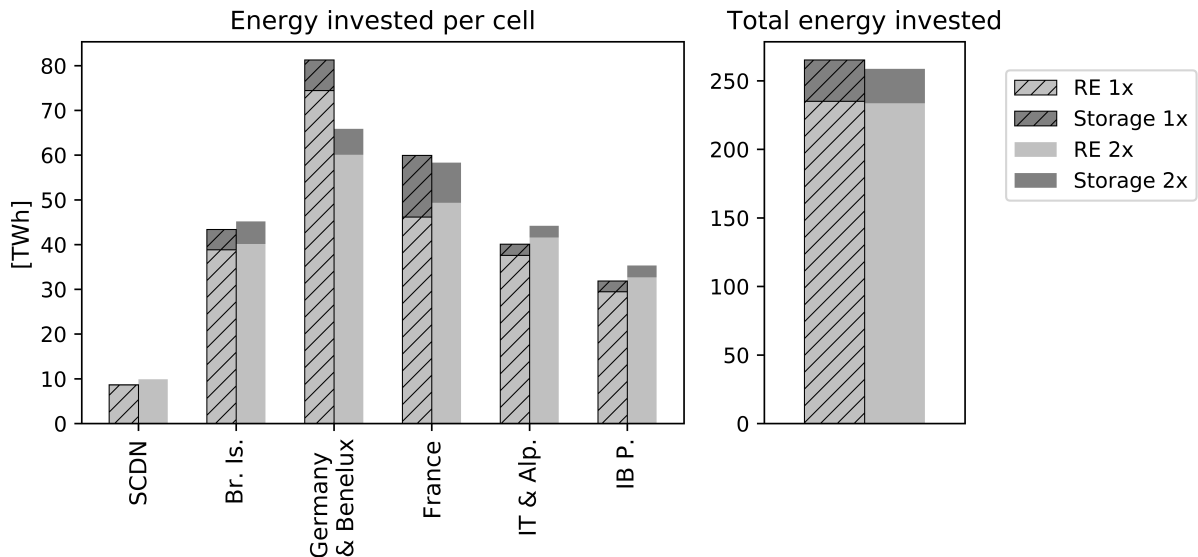

Figure 5.17: Energy invested per cell and total energy invested for scenario 1 and 2.

Figure 5.18 details the variation of the energy invested in storage. It appears that the decrease of the energy cost comes mainly from the decrease of 40% of the batteries installed in France. Moreover, the energy invested in storage lowers for Germany & Benelux and increases for all other cells. The explanations of these observations are made in Section 5.2.5. Figure 5.18 underlines again that the main cost of the storage lies in the batteries (more than 80%) and that the cost of the gas storage is negligible (less than 1%).

In Table 5.13, the net EROI of each cell for both scenarios is presented. The EROI of the exporting cells (Scandinavia, British Isles, Italy and Alpine states) decreases mainly due to an increase of the energy invested in RE assets. However, an exception in the exporting cells is observed with France. Even if its RE assets increase, its EROI increases due to a strong reduction of battery capacity. On the other hand, Germany & Benelux EROI increases due to the reduction of RE assets and storage.

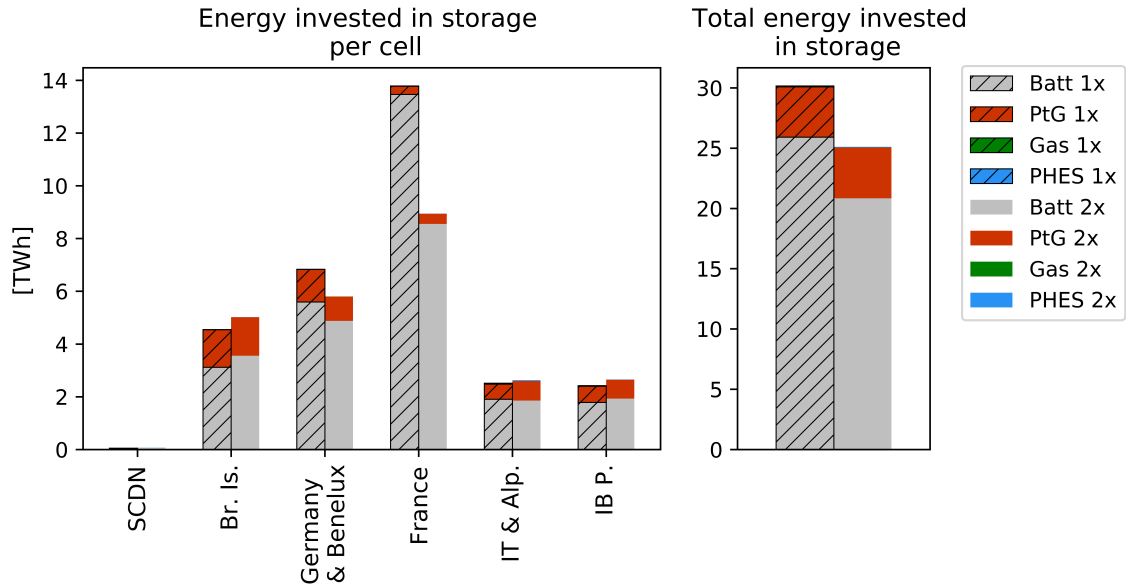

Figure 5.18: Energy invested in storage per cell and global energy invested in storage for scenario 1 and 2.

Table 5.13: Cells EROI in scenario 1 and 2.

Cell	Scenario 1	Scenario 2
Scandinavia	35.0	30.9
British Isles	8.5	8.2
Germany & Benelux	8.9	11.0
France	8.0	8.2
Italy and Alpine states	11.3	10.2
Iberian Peninsula	9.5	8.6
Global EROI	9.9	10.2

It is interesting to notice that the decrease in energy invested is higher in this situation (six cells) than in the two-cell study (Germany & Benelux and France). Indeed, the reduction of energy investment induced by doubling the interconnection capacity is of 2.5% for the Western Europe model and of 1.3% for the two-cell study. The presence of multiple interconnected actors allows thus to reach a more efficient electricity system.

5.2.2 Production and annual exchanges

Figure 5.19 displays the annual productions and exchanges for the two scenarios.

The production shares of the different cells mainly remain similar between the two scenarios. Still, some differences are noticeable. One can observe an increase of the offshore production share in Scandinavia as well as an increase of the solar share in France. Germany & Benelux, on the other hand, decreases its onshore production. The production of all cells, except Germany & Benelux, increases with an additional production from 3.4% for British Isles up to 10.3% for Iberian Peninsula (see production increases in Table 5.14). The production of Germany & Benelux drastically decreases with a drop of 18.5%. The total energy production of the system remains identical but the exporter/importer behaviour of the cells is accentuated.

Regarding the energy exchanges between cells, it is noticeable that all the net exchanges increase but with different magnitude. As can be seen in Table 5.14, the southern cells experience

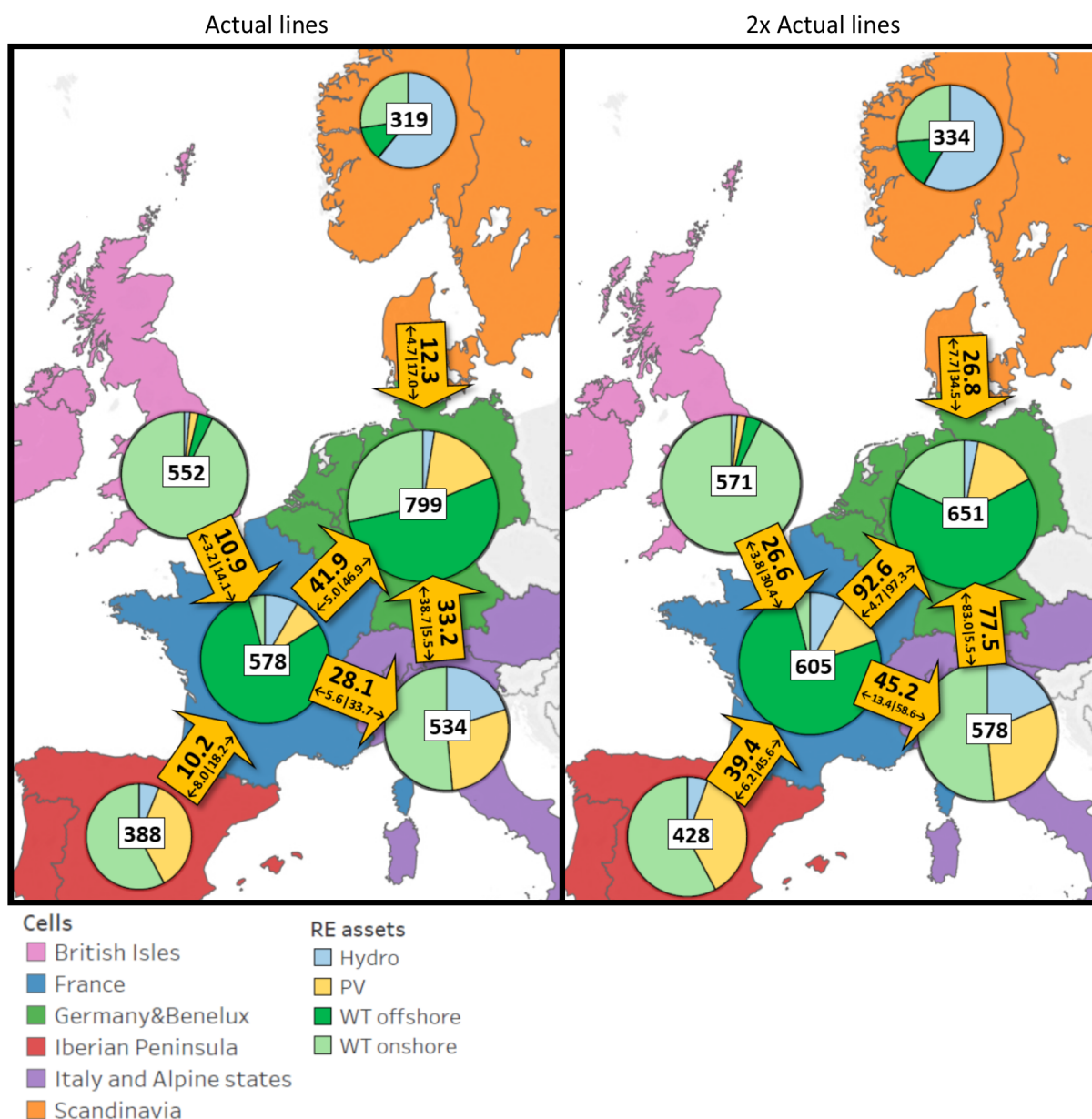

Figure 5.19: RE productions and annual exchanges in TWh. On the left (resp. right), the actual lines (resp. 2× the actual lines) capacity scenario. Yellow arrows represent the net exchanges and sub-arrows represent imports/exports.

Table 5.14: Ratio of production to consumption, net import and net export for scenario 1 and 2.

Exporting cells	Production/Consumption		Production increase	Net export [TWh]		Net Export increase
	Scenario 1	Scenario 2		Scenario 1	Scenario 2	
Scandinavia	105.2%	110.0%	4.7%	12.3	26.8	117.9%
British Isles	149.4%	154.6%	3.4%	10.9	26.6	144.0%
France	120.7%	126.5%	4.7%	48.8	71.7	46.9%
Italy and Alpine States	118.2%	127.7%	8.2%	5.1	32.3	533.3%
Iberian Peninsula	128.5%	141.6%	10.3%	10.2	39.4	286.3%
Importing cells	Production/Consumption		Production increase	Net import [TWh]		Net import increase
	Scenario 1	Scenario 2		Scenario 1	Scenario 2	
Germany & Benelux	110.4%	90.1%	-18.5%	87.3	196.8	125.4%

an important increase of their net export, four to six times more important than in previous case. On the other hand, the net export of Scandinavia and British Isles is around two times higher than in the first scenario. France presents the lowest increase of export, with an increase of 46.9%.

The huge increase of export of Italy and Alpine states and the relatively low increase of France are linked. Indeed, in the previous scenario, France was hogging the line of Italy and Alpine states to send its exports towards Germany & Benelux. But since the offshore WTs of France already reached their upper limit in the first scenario and that Italy and Alpine states has a better irradiance than France, a stronger increase of production of Italy and Alpine states is observed. Much more space is let for Italy and Alpine states to export its power to Germany & Benelux through its direct line. Moreover, during peaks of solar production, the link with France is used to reach Germany & Benelux. Only 0.84 TWh were exported from Italy and Alpine states to Germany & Benelux passing through France in the first scenario against 2.3 TWh in the second.

The total energy exchanged before consumption represents 8% of the production compared to 4% in scenario 1. Even with the capacities of exchange doubled, the utilisation factor of all lines remains higher than 97%.

5.2.3 Energy flows

In Figures 5.20 and 5.21, the Sankey diagram of the energy flows of the system is represented for scenario 1 and 2 respectively.

The production mixes of the two scenarios are close. Only small variations are observed: onshore production experiences a decrease of 3% while PV and offshore productions increase by 6% and 1.6% respectively.

One can notice the increase of the direct consumption (1.5%) and the decrease of the energy stored (2.3%). Regarding the storage types, less energy is stored in the batteries and PHES in scenario 2 but the energy stored in the gas storage increases. Even though the energy stored decreases, the storage losses increase due to a higher utilisation of the gas storage.

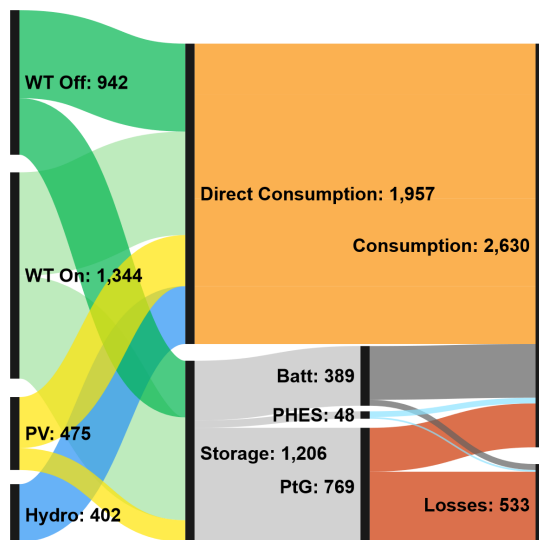

Figure 5.20: Western Europe energy flows with the actual capacities of the lines (scenario 1) [TWh].

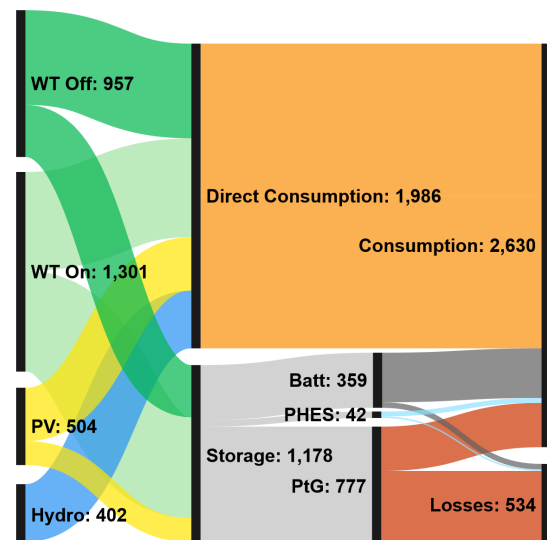

Figure 5.21: Western Europe energy flows with 2 times the actual capacities of the lines (scenario 2) [TWh].

5.2.4 RE assets

The RE assets for the two scenarios are presented in Figure 5.22. A summary of the results of the RE and storage assets is presented in Table E.2.

A decrease of PV panels and onshore WTs in Germany & Benelux as well as an increase of the installed (and not at their upper limit) means of production in all the other cells is noticed. This transfer of production from Germany & Benelux to the other cells with the increase of the line was similarly observed in the two-cell analysis, Section 4.2. As detailed earlier, the system tends, as long as the lines allow it, to install the PV panels in the cells with the best load factors and the WTs in the parks with the best EROIs. The solar production of Germany & Benelux is thus transferred to the cells with a better irradiance (France, Italy and Alpine States and Iberian Peninsula) as well as the onshore production of Germany & Benelux, presenting the lowest onshore EROI, to all the other cells of the system. Nevertheless, its offshore WT production remains unchanged thanks to its good absorption and EROI.

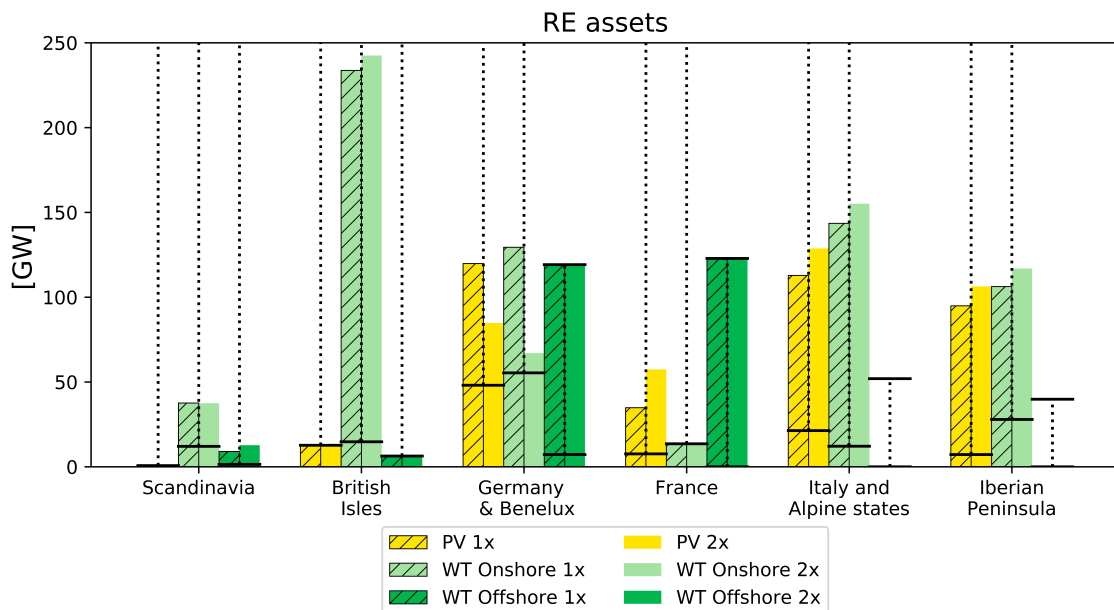

Figure 5.22: Nominal power of the RE assets for scenario 1 and 2. The horizontal black lines correspond to the upper and lower limits, and the dotted lines to the domain of solution.

5.2.5 Storage assets

In Figure 5.23 the variation of the storage assets with the variation of the line is displayed.

As observed in Section 5.2.4, a transfer of part of the RE assets of Germany & Benelux to cells with better EROIs occurs with the increase of the exchange capacities and this until the lines are saturated.

During peaks of production, the production of these RE assets transferred is exported towards Germany & Benelux using the full capacity of the lines and is, for the main part, directly consumed. The overproduction of these RE assets, which was before stored in Germany & Benelux, is now stored in the cells where the RE assets are installed and transferred to Germany & Benelux during drops of production in order to use the lines at their maximum capacity all the time. For this reason, one observes a transfer of storage from Germany & Benelux to the cells where its RE assets are transferred. If the example of the southern cells (Italy and Alpine states and Iberian Peninsula) is taken, one observes an increase of their PtG power and gas storage

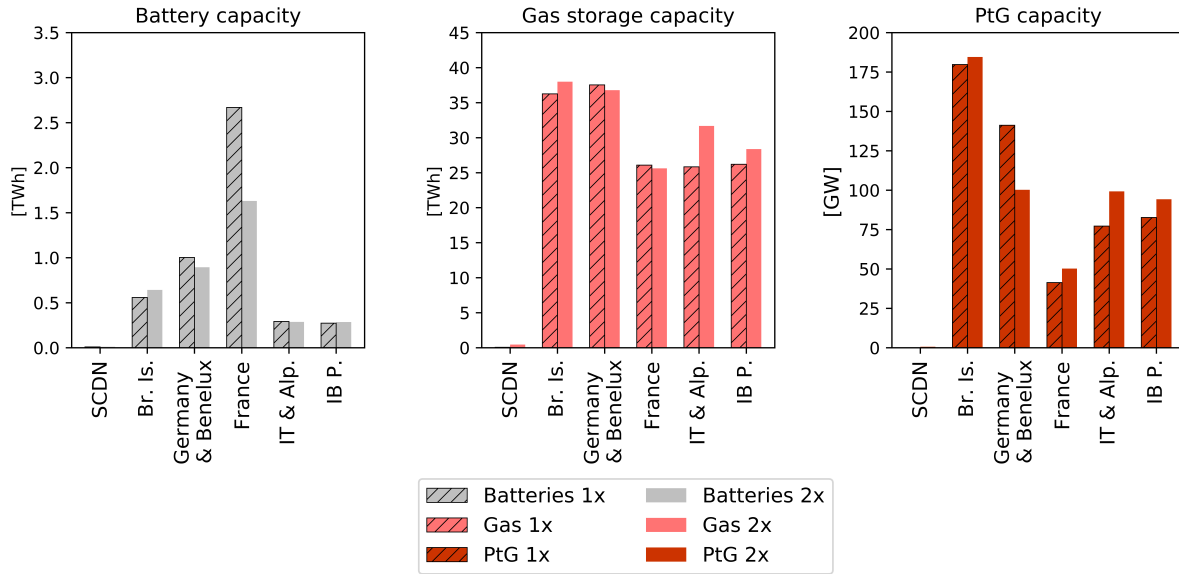

Figure 5.23: Storage assets for the actual line capacity and two times this capacity.

capacity. Indeed, during the peaks of solar production in the summer, the lines connecting Germany & Benelux are saturated with the solar production and part of the overproduction is stored directly in the PtG of the southern cells for a long-term storage. During the winter, this energy is taken out of the gas storage of the southern cells and exported to Germany & Benelux. The percentage of energy from the gas storage used to be exported to Germany & Benelux passes from 5% for the scenario 1 to 17% for scenario 2 in Italy and Alpine states and from 6% to 12% for Iberian Peninsula.

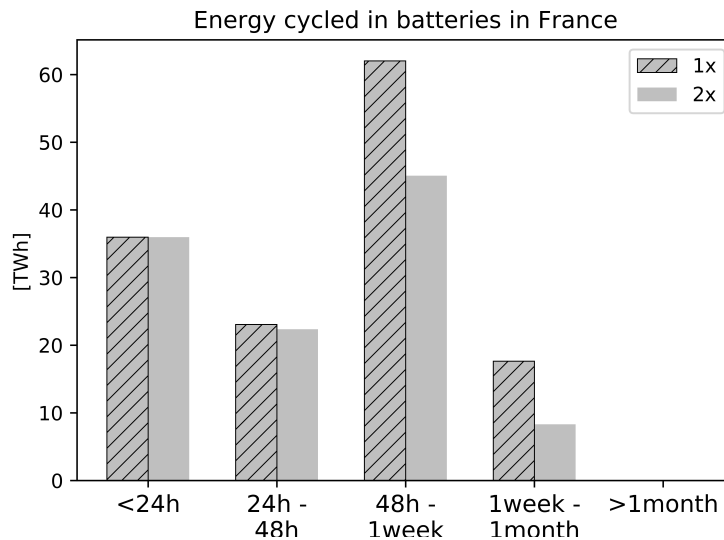

Figure 5.24: Energy cycled in batteries in France for different duration.

The important decrease of batteries in France is the main reason of the decrease of the energy invested in storage, as highlighted in Section 5.2.1. In the previous study (Section 5.1.5), the low ratio of CCGT power to average consumption of France leading to a storage mix based on batteries and their utilisation for the mid-term storage was developed. The increase of the exchange capacities allows France to export more of its mid-term overproduction and to import more during mid-term underproduction. In Figure 5.24, the energy cycled in the batteries for

different durations is presented. The energy cycled in a storage corresponds to the quantity of energy which entered and left the storage within a certain period. It is noticeable that the mid-term utilisation of the batteries in France is highly decreased while the short-term utilisation remains equivalent, which leads to a decrease of their capacity. The low CCGT power in France is thus partly compensated by the exchanges with the other cells.

5.2.6 Electricity exchanges

In Table 5.15, the annual import and export of each cell for both scenarios is presented.

Table 5.15: Annual import and export for scenario 1 and 2.

Cell	Annual import [TWh]		Annual export [TWh]	
	Scenario 1	Scenario 2	Scenario 1	Scenario 2
Scandinavia	4.7	7.7	17.0	34.5
British Isles	3.2	3.8	14.1	30.4
Germany & Benelux	91.5	198.5	4.2	1.7
France	10.3	16.9	59.1	88.5
Italy and Alpine States	15.1	20.2	20.2	52.5
Iberian Peninsula	8.0	6.2	18.2	45.6

In the previous sections, it has been shown that all the exporting cells increase their annual net export and that the importing cells increase their annual net import. However, it is noticeable from Table 5.15 that most of the exporting cells also increase their annual import. Taking Scandinavia as an example, besides the increase of its net export by 117.9% (see Table 5.14), it also increases its annual import by 65%. This highlights that, in addition to the transfer of RE assets to the cells with the best EROI, the increase of the exchange capacities enhances the exchanges between the cells to lower the storage needs and increase the direct consumption.

5.3 Conclusion

Several important observations were highlighted concerning the study of the Western Europe 100% RE electricity system and are summarised hereafter.

Regarding the production, the system can be divided in three main categories. The southern cells, i.e. Italy and Alpine states and Iberian Peninsula, are characterised by high PV share coupled with onshore WTs. The central cells, i.e. France and Germany & Benelux, mainly base their production on offshore WTs and reach their maximum potential for this asset. In order to cover the rest of the demand, onshore WTs and PV panels are installed. Finally, the northern cells (Scandinavia and British Isles) are characterised by a strong production of onshore WTs with smaller shares of offshore WTs and no solar production. As for the two-cell analysis, the production mix is explained by the gross EROI and absorption of the RE assets. It is highlighted that Germany & Benelux behaves like an importer. Due to its low EROIs for onshore WTs and PV panels compared to other cells of Western Europe, its production is transferred to the cells with higher EROIs. To reach the optimal 100% RE electricity system based on the energy cost, cells have to deploy a significant amount of production assets. The area of the PV installations in the southern cells represents around 15 m² of panels per inhabitant, while the area occupied by the assets for British Isles and Germany & Benelux represents 15% and 20% of the inland territory respectively. Looking at the global system, 42% of the production is provided by onshore WTs, 30% by offshore WTs, 15% by the PV panels and 13% by the hydroelectric power stations.

The necessity of storage to reach an optimum integration of the renewable production is clear.

Indeed, in a 100% RE scenario with the actual exchange capacities, 38% of the total production is stored before being consumed leading to a loss of 17% of the energy produced. Regarding the global system, 64% of the energy stored is stored in the gas storage, 32% in the batteries and 4% in the PHES. The total storage capacity of Western Europe consists of a battery capacity of 4.8 TWh, a gas storage of 152 TWh and a total PtG power of 522 GW. The PHES represents a marginal part of the storage capacity due to the low already-installed capacity.

Regarding the storage mix of the cells, particularities have to be mentioned. It is observed with British Isles that the dependence to a single intermittent mean of production has a strong impact on the storage mix. Indeed, relying only on onshore WTs production which presents strong mid-term variations and an important decrease during the summer induces high mid and long-term needs, leading to high PtG capacity and important losses. In fact, 45% of the total production of British Isles enters the gas storage. This leads to a production equal to 1.5 times its consumption which is necessary to balance the high losses.

Moreover, the impact of a low ratio of the CCGT power to the mean power consumption on the storage mix is pointed with France. Due to the low value of this ratio, it has to rely on batteries for its mid-term storage needs leading to a strong increase of the energy invested in storage. Indeed, if this ratio is increased to be equal to the average of the other cells, the energy invested in the storage decreases by 70% in France and the total energy investment of the system decreases by 1.2%.

The case of Scandinavia shows the benefits of a flexible renewable mean of production coupled with intermittent sources. Indeed, dams, representing 60% of the production of the cell, are able to supply the demand during wind drops and to stop the production during wind surplus. No storage is thus needed.

Finally, a high short-term utilisation of the batteries for the cells with high PV share (Italy and Alpine states and Iberian Peninsula) is observed due to the important day/night variation of production. Approximately 20% of the solar production is stored in the batteries during the day and consumed during the following night.

A utilisation factor of the line close to 97% is observed for all the lines of the system. The energy exchanges are thus used at their maximal potential to lower the energy investment. The exchanges favour the installation of the RE assets in the cells presenting the best EROI and allow to reduce the storage needs. The doubling of the line capacities leads to a decrease of 17% of the storage investment but only to a decrease of 2.5% of the total energy invested. Indeed, the energy invested in the RE assets only decreases by 0.6% representing 90% of the total investment. The decrease of the energy invested in the storage is mainly due to the decrease of the batteries installed in France. Indeed, thanks to the better interconnection, the impact of its low CCGT power is reduced by the other cells covering its mid-term storage needs. Moreover, the increase of the exchange capacities enhances the importing/exporting behaviour of the cells to take advantage of the best EROIs and increases the exchanges between cells in order to lower the storage needs.

Comparing the results with the ones obtained for the two-cell analysis, it is observed that the energy invested in the storage for both system is close (30 TWh for the six-cell system and 27 TWh for the two-cell) while the consumption is more than doubled. Moreover, the doubling of the exchange capacities for the six-cell decreases the total energy cost by 2.5% as said earlier while, for the two-cell, it only decreases by 1.3%. This reflects that the presence of many actors and their interconnection is a key point in reaching an optimal electricity system with high RE share based on the energy investment.

Conclusion

The willingness of the industrialised countries for independency towards limited energy resources and for decarbonisation of the electricity sector is going to lead to important changes in their electricity system. However, the optimal electricity system of tomorrow remains uncertain. Wind turbines and solar panels are certainly going to be the main sources of production but in which proportion and how their intermittency is going to be managed has still to be determined. Moreover, most electric interconnections between countries were not initially developed to deal with high solar and wind production. Therefore, it remains unclear how these interconnections should evolve in order to integrate efficiently the renewable production. The current work tends to answer these questions for the case of Western Europe.

A 100% RE electricity system of Western Europe has been modelled to quantify the RE and storage assets as well as to study the impact of the exchange capacities.

To do so, a tool has been developed based on a previous model applied to Belgium presented in [71]. It models the electricity system of a given area (city, countries, continents) for a given period (day, month, year) and time step. The area is divided in several cells connected through transmission lines and pipelines in order to exchange electricity and gas. The model optimises the RE and storage assets of the electric system to maximise the net EROI. In comparison with the previous model, the new tool can be applied to different electricity systems with different number of cells and includes the coal and hydroelectric production. The tool has been validated based on the results for the case of the Belgium transition presented in [71]. Finally, our model has been applied to the case of Western Europe.

Six cells have been defined based on their energy mix, policies and meteorological conditions in order to model Western Europe:

- Scandinavia (Norway, Sweden, Denmark)
- British Isles (United Kingdom, Ireland)
- Germany & Benelux (Germany, Belgium, Netherlands, Luxembourg)
- France
- Italy and Alpine states (Italy, Switzerland, Austria)
- Iberian Peninsula (Spain, Portugal)

Despite the low resolution of the cells, the system still allows to highlight the different production and consumption profiles as well as the distinct renewable potentials. Based on this six-cell system, two studies have been led.

The first study involves the two-cell electricity system composed of Germany & Benelux and France and the second analyses the complete six-cell Western Europe model. For both studies, a 100% RE system has been considered and the impact of the transmission lines capacity has been investigated. The main conclusions that can be drawn regarding the fully renewable electricity system of Western Europe are presented hereafter.

First, it has been observed that the energy cost lies mainly in the RE assets, representing 90% of the total investment. From the 10% invested in the storage, 86% lies in the batteries, 13.5% in the PtG and the rest in the gas storage and PHES. The important cost of the batteries

and the negligible cost of the gas storage is there highlighted.

Regarding the production, the optimal mix is composed of 42% of onshore WT, 30% of offshore WT, 15% of PV and 13% of hydroelectric production. The important role of the WTs is pointed. Indeed, the installations of the RE assets is directly linked to their EROI as well as their absorption by the consumption (direct consumption or necessity of storage). The wind presents an EROI between 9.1 (Italy and Alpine states offshore) and 15.6 (Scandinavia onshore) while PV presents an EROI between 6.1 (Scandinavia) and 10.3 (Iberian Peninsula). Despite their lower EROI, PV panels are still installed in all the cells except the northern ones. Indeed, it has been shown that the absorption of the solar production (70% of direct consumption) is better than for the WTs (50% and 60% of direct consumption for onshore and offshore respectively). However, the EROIs are based on actual values of energy cost and load factor. This may change in the upcoming years and maybe reverse the trend. For example, numerous methods aimed at recycling the solar panels are under study which could strongly reduce their energy cost [39].

The complementarity of solar and wind productions is a point that has to be raised. Indeed, the wind production presents a strong decrease in the summer when the solar production increases, therefore allowing to reduce the long-term storage needs if both are present in the production mix. Moreover, the impact of the day/night behaviour of the solar production and of the frequent wind drops on the total production is decreased if the two assets are used together, reducing the short and mid-term storage needs.

Three different production mixes have been highlighted: the northern cells (Scandinavia and British Isles) based on onshore WTs, the central cells (France and Germany & Benelux) with a mixed production but mainly based on offshore WTs and the southern cells (Italy and Alpine states and Iberian Peninsula) presenting a high solar production. This trend directly follows the distribution of the EROIs of the technologies throughout Western Europe.

The important role of the storage in an electricity system with a high RE share is pointed. Indeed, in a 100% RE scenario with the actual line capacities, 38% of the total production is stored before being consumed leading to a loss of 17% of the energy produced. From the total energy stored, 64% is stored in the gas storage, 32% in the batteries and 4% in the PHES. The total storage capacity of Western Europe consists of a battery capacity of 4.8 TWh, a gas storage of 152 TWh and a total PtG power of 522 GW. As expected, the batteries are used for a short-term usage (less than one day), the PHES for the mid-term storage needs (days-weeks) and the gas storage for the long-term (months). This confirms the choice of appropriate storage costs and characteristics. However, the current PHES installed capacity is marginal compared to the storage needs encountered. Due to the lack of a proper mid-term mean of storage, the gas storage is also used to cover the mid-term needs, leading to high losses. The installation cost of PHES should therefore be investigated and its remaining potential in Europe should be further studied to assess the energy cost-effectiveness of such means of storage. Other storage facilities such as flow batteries presenting power/energy independent sizing could also bring a solution to mid-term storage needs [5].

As it has been observed in the case of France, the CCGT installed power may limit the use of the gas storage and increase strongly the energy invested in the storage by installing batteries to cover the mid-term storage needs. It would then be interesting to investigate the profitability of new Gas to Power (GtP) units within the model based on a given energy cost and to optimise the installation of such an asset.

A similar optimal storage mix is observed for the cells not limited by a small CCGT installed power and presenting a mixed production (Germany & Benelux, Italy and Alpine states, Iberian Peninsula and France if CCGT multiplied by 3): 35% of the energy produced enters the storage, 10% in the battery and 25% in the gas storage.

The positive effect of flexible renewable means of production is noticed with the hydroelectric production in Scandinavia reducing strongly the storage needs of this cell. In order for Western

Europe to reach a 100% RE system, the development of flexible renewable sources may be a key point. This could be achieved by the governments by promoting the development of hydroelectric, biogas and biomass production but also other technologies that are less widespread like tidal power station or concentrated solar power (CSP) plants with thermal storage. Biogas and biomass production units are already implemented in Western Europe countries and have been considered as a part of the available CCGT power in the model presented but remain marginal (0.5 and 0.4% of the CCGT equivalent capacity of Western Europe respectively). A dissociation of these renewable production units from the CCGT should be made if the installed capacities of these sources is increased in the future. Even if less widely used, tidal power and CSP plants are already implemented in Western Europe. A tidal power station of 240 MW and 500 GWh annual production is for example already installed in La Rance (France) [38] and Spain has already numerous concentrated solar power plant with storage like Astexol II (50 MW, 170 GWh/year, 8 hours storage) [76] based on the parabolic trough system, which is the most mature CSP technology [74].

The impact of the interconnection on the Western Europe electricity system has been studied. However, one has to remind that the energy cost of the line was not taken into account. By doubling the exchange capacities, a decrease of 2.5% of the total energy investment has been observed: the energy invested in the RE assets decreased by 0.6% and in the storage assets by 17%. The positive impact of the development of the grid regarding the storage has been clearly noticed but it does not strongly influence the total energy invested. In order to determine the role of the interconnection in the electricity system, the energy cost of the increase of the line has then to be determined. However, no studies on the subject at the scale of the present analysis have been made yet.

Comparing the results of the isolated 100% RE electricity system composed only of Germany & Benelux and France with the results of the six-cell system, a decrease of 55% of the energy investment in the storage regarding the total energy consumed has been observed. The presence of many actors and their interconnection is therefore a key point in reaching an optimal electricity system with high RE share based on the energy investment.

Several hypotheses have been made in this study. Some are discussed hereafter to propose avenues for improvement.

For each cell, one PV park, one offshore and one onshore WT park are implemented with their own irradiance and wind profile. Regarding the size of the cells, it is a strong hypothesis to define the complete production of a RE asset of a cell based only on one input profile. However, the study of the data used for the wind speed and irradiance distributions ("Typical years" from [73]) across Western Europe pointed the strong correlation of the meteorological conditions throughout the area studied. The increase of the number of parks implemented had then only a marginal impact on the solution but led to a strong increase of the computation time. It would therefore be interesting to use real meteorological data in order to confirm this choice.

Each park is characterised by a load factor computed based on the actual installations of each country of the cell. However, for certain countries, values were surprisingly high or low compared to the expectations. For some countries, offshore load factor is non-existent since no park are installed. A more precise estimation of the future potential load factors in Western Europe could correct the inaccuracies and inconsistent behaviours observed in certain cells.

The technical potentials of the RE assets correspond to the total area of the cell suitable for the installation of these assets. However, for the WTs, these areas do not necessarily present a load factor as interesting as the one fixed for the cell. Indeed, one can suppose that the already-installed WTs are placed in the most efficient locations. It would then be interesting to use the method developed in [24], which defines the technical potential of a country in function of a minimum EROI wanted.

Finally, the actual exchange capacities between the cells are based on data from 2011

[28]. It would be interesting to study the new lines implemented since then or to model the interconnections based on expectations of the Western European grid by 2030 or 2050.

The tool developed provides clear answers to the questions raised regarding the optimal energy system of tomorrow based on the energy investment. One can affirm that storage is going to play a key role in the energy transition of Western Europe. Short-term as well as long-term storage systems have to be installed in substantial quantities to reach an optimal mix. More than one third of the energy produced will have to be stored. Interconnections between countries will play an important role to integrate intermittent energy sources, allowing to reduce the storage needs in the system. However, the energy cost of the lines has to be studied to determine the real benefits of the increase of their capacity regarding the total energy investment.

The future work will focus on the analysis of the interconnections between countries in Western Europe by investigating the potential future transmission lines. In addition, a study will be led to determine the energy cost of the increase of the interconnections. Finally, flow batteries will be integrated in the model and their capacity, as well as the one of the PHES, will be optimised.

Appendix A

Model description and implementation

A.1 Tables

Table A.1: Indices table.

Indices	Meaning
i	Refers to a given PV park in a cell
j	Refers to a given WT park in a cell
k	Refers to a given battery park in a cell
c	Refers to a given cell in the system
c_n	Refers to a neighbouring cell of cell c
b	Refers to the battery parks
PV	Refers to the PV parks
WT	Refers to the WT parks
$CCGT$	Refers to the CCGT production
$coal$	Refers to the coal production
nuc	Refers to the nuclear production
dam	Refers to the dam production
$runriver$	Refers to the run-of-river production
$PHES$	Refers to the PHES
PtG	Refers to the PtG
gas	Refers to the gas
imp	Refers to the import
$cons$	Refers to the consumption
in	Refers to an incoming quantity
out	Refers to an outgoing quantity
$exch$	Refers to exchanged quantity between cells
opt	Refers to an optimal quantity
max	Refers to a maximum quantity
min	Refers to a minimum quantity
$inst$	Refers to an installed quantity

Appendix B

Validation

B.1 Tables

B.1.1 Grid

Table B.1: Belgian grid parameters [71].

Exchange Line capacity [MW]	2800
Maximum import power onshore [MW]	4500
Maximum import power offshore [MW]	0

B.1.2 Offshore cell

The wind file is from 2015, in the city of Zeebrugge.

Table B.2: Offshore cell parameters [71].

System	Characteristic	Value
Wind Turbine	Maximum power installed [MW]	1500
	Minimum power installed [MW]	300
	Energy invested [GWh]	39.818
	Cut-in wind speed [m/s]	3
	Rated wind speed [m/s]	11.4
	Cut-out wind speed [m/s]	25
	Lifetime [years]	25
PV Panel	Maximum power installed	0
	Minimum power installed	0
CCGT	Installed capacity [W]	0
Battery	Maximum installed storage capacity [GWh]	10
	Minimum installed storage capacity [GWh]	0
	Energy invested [Wh/Wh]	200
	Input efficiency	0.9
	Output efficiency	1
	Charge rate [W/Wh]	1
	Discharge rate [W/Wh]	1
	Leak [/h]	4.167e-6
	Depth of discharge	1
	Number of cycles	6000
Lifetime [years]	15	

B.1.3 Onshore cell

The irradiance profile is from the year 2016, in the city of Spa. The wind profile is a 5 years average from 2011 to 2016, in the city of Spa. The consumption profile is from the year 2015.

Table B.3: Onshore cell parameters [71].

System	Characteristic	Value
Wind Turbine	Maximum power installed [MW]	2 000
	Minimum power installed [MW]	200
	Energy invested [GWh/WT]	18.713
	Rating power [MW]	5
	Cut-in wind speed [m/s]	3
	Rated wind speed [m/s]	11.4
	Cut-out wind speed [m/s]	25
	Lifetime [years]	25
PV Panel	Maximum power [MW]	10 000
	Minimum power [MW]	460
	Energy invested [kWh/m ²]	428
	Lifetime [years]	30
PHES	ESOI	704
	Storage capacity [GWh]	5
	Pumping power [GW]	1.164
	Turbine power [GW]	1.164
	Pumping efficiency	0.9
	Turbine efficiency	0.85
PtG	Maximum power installed [MW]	1000
	Energy invested [Wh/W]	100
	Minimum charge	0.15
	Efficiency	0.63
	Full load lifetime [h]	10 000
CCGT	Installed power [MW]	5190
	Efficiency	0.59
Gas storage	Maximum installed storage capacity [TWh]	10
	Energy invested [Wh/Wh]	0.001
	Lifetime [years]	25
Battery	Maximum installed storage capacity [TWh]	1
	Minimum installed storage capacity [TWh]	0
	Energy invested [Wh/Wh]	132
	Input efficiency	0.9
	Output efficiency	1
	Charge rate [W/Wh]	1/5
	Discharge rate [W/Wh]	1/5
	Leak [/h]	4.167e-6
	Depth of discharge	1
	Number of cycles	6000
Lifetime [years]	15	

Appendix C

Western Europe model

C.1 Tables

Table C.1: Cells installed generation capacity for each type of generation [MW] [29].

	Scandinavia	British Isles	Germany Benelux	France	Italy and Alpine states	Iberian Peninsula
Biogas	121,96	1,00	11,00	428,25	1427,00	231,86
Biomass	4378,72	2097,00	8545,00	653,31	2354,00	1135,58
Fossil Brown coal/Lignite	0	0	20804,00		0	1055,77
Fossil coal-derived gas	0	0	0		2057,00	0
Fossil Gas	3558,37	35339,00	55838,50	11851,46	49124,00	36765,03
Fossil Hard Coal	4504,90	15000,00	29641,24	2997,00	7952,00	10704,50
Fossil mixed fuels	120,00	0	1404,30		436,00	0
Fossil Oil	3742,77	1791,00	3934,59	4098,00	15711,00	3387,71
Fossil other	0	0	0		414,00	17,80
Fossil Peat	0	228,00	0		0	0
Geothermal	0	0	37,75		963,00	0
Hydro marine tidal	0,30	0	0	240,00	0	0
Hydro mixed pumped storage Non-RE	0	0	1061,60		0	0
Hydro mixed pumped storage RE	0	1,00	0	2455,00	12603,00	5893,15
Hydro PHES	0	292,00	7818,34		4753,00	3328,89
Hydro Pure storage	47961,00	2828,00	698,00		13258,15	12740,65
Hydro Run-of-river	6,28	1230,00	3827,00	21094,69	22287,07	5562,50
Nuclear	8586,00	9248,00	15914,00	63130,00	3333,00	7117,29
Other	115,77	269,00	0		0	0
Other Non-RE	0	0	77,00		3361,00	53,20
Other RE	36,00	338,00	508,00	1727,66	316,00	16,19
Solar PV	913,54	12900,00	48112,00	7646,57	22087,00	5165,67
Solar Thermal	0	0	0		0	2299,43
Waste Non-RE	445,00	39,50	1155,45		399,00	648,14
Waste RE	387,42	40,50	1503,45	867,63	377,00	106,82
Wind offshore	1263,80	5400,00	7206,00		0	0
Wind onshore	12007,54	16030,00	55425,00	13539,35	12568,00	28095,00

Table C.2: Cell gathered installed generation capacity.

	Scandinavia	British Isles	Germany & Benelux	France	Italy and Alpine states	Iberian Peninsula
Conventional [GW]	26.0	64.1	138.8	84.0	86.9	61.2
CCGT	49.6%	62.1%	52.2%	21.3%	84.7%	69.2%
Coal	17.4%	23.4%	36.3%	3.6%	11.5%	19.2%
Nuclear	33.1%	14.4%	11.5%	75.1%	3.8%	11.6%
Solar [GW]	0.9	12.9	48.1	7.6	22.1	7.5
Wind [GW]	13.3	21.4	62.6	13.5	12.6	28.1
WT onshore	90.5%	74.8%	88.5%	100.0%	100.0%	100.0%
WT offshore	9.5%	25.2%	11.5%	0.0%	0.0%	0.0%
Hydro [GW]	48.0	4.1	4.5	23.5	48.1	24.2
Dam	100.0%	69.7%	15.4%	10.4%	53.7%	77.0%
Run-of-the-river	0.0%	30.3%	84.6%	89.6%	46.3%	23.0%

Table C.3: Repartition of the available areas into land use categories, and for each category the land use factor (1) [24].

	Total Area [km^2]	Total Onshore Area	Total Offshore Area	Sparse Vegetation	Forests	Croplands
Land Cover Indexes				140, 150, 200	40, 50, 60, 70, 90, 100	14
Suitability Factor Solar %				10	0	10
Suitability Factor Wind %				90	10	70
Norway	1.248.064	331.508	916.556	165.267	102.510	0
Sweden	603.721	449.831	153.890	55.205	285.776	2.485
Denmark	145.111	46.348	98.764	415	8.362	10.074
Germany	413.083	357.309	55.774	14.008	121.292	78.740
Netherlands	99.372	36.480	62.892	4.656	8.109	5.087
Belgium	33.810	30.421	3.389	791	8.817	5.947
Luxembourg	2.715	2.715	0	479	878	239
France	890.867	549.866	341.001	28.370	107.439	193.538
Italy	838.595	304.376	534.218	23.033	73.877	66.232
Switzerland	41.132	41.132	0	5.684	13.783	3.220
Austria	83.046	83.046	0	4.610	39.507	10.922
United Kingdom	965.818	250.034	715.785	71.513	10.171	43.480
Ireland	496.489	71.290	425.199	43.694	1.638	1.865
Spain	1.509.211	507.486	1.001.725	56.510	98.752	68.828
Portugal	1.812.683	92.893	1.719.790	10.284	22.609	5.708

Table C.4: Repartition of the available areas into land use categories, and for each category the land use factor (2) [24].

	Shrubland	Mosaic Vegetation Croplands	Mosaic Grassland, Forest, Shrubland	Urban Areas	Flooded Area, Ice, etc	Water Bodies
Land Cover Indexes	130	20, 30	110, 120	190	11, 160, 170, 180, 220	210
Suitability Factor Solar %	10	5	5	0	0	0
Suitability Factor Wind %	60	50	50	0	0	Depends on distance to coast & water depth
Norway	0	99	24.184	269	26.877	928.858
Sweden	0	5.017	40.288	2.473	29.516	182.961
Denmark	0	17.092	5.446	348	418	102.956
Germany	0	88.792	38.131	10.261	1.218	60.642
Netherlands	0	8.968	4.824	2.574	224	64.932
Belgium	0	9.519	3.709	1.404	79	3.544
Luxembourg	0	720	399	0	0	0
France	824	138.658	69.039	6.425	88	346.486
Italy	5.581	106.797	7.196	12.014	3.323	540.541
Switzerland	0	11.108	5.220	253	256	1.608
Austria	0	22.096	4.662	498	168	583
United Kingdom	122	17.389	87.160	12.063	138	723.783
Ireland	0	1.780	18.396	592	218	428.305
Spain	53.592	165.167	38.626	8.155	13.474	1.006.107
Portugal	14.722	26.080	7.373	2.089	1.725	1.722.094

Table C.5: Repartition of the available areas into land use categories, and for each category the land use factor : Offshore [24].

	5 - 20 nmi from coast, depth <200 m	<5 nmi from coast, depth <200 m	>20 nmi from coast, depth <200 m	5 - 20 nmi from coast, depth <1000 m	<5 nmi from coast, depth <1000 m	>20 nmi from coast, depth <1000 m
Land Cover Indexes						
Suitability Factor Solar %	0	0	0	0	0	0
Suitability Factor Wind %	10	33	67	10	33	67
Norway	65.498	28.312	102.409	73.203	87.042	478.383
Sweden	39.771	65.723	45.590	39.771	67.094	47.025
Denmark	23.538	31.196	43.245	23.538	31.196	44.029
Germany	14.029	15.618	26.126	14.029	15.618	26.126
Netherlands	7.701	10.602	44.589	7.701	10.602	44.589
Belgium	618	1.543	1.228	618	1.543	1.228
Luxembourg	0	0	0	0	0	0
France	28.328	48.648	81.864	31.149	54.131	100.238
Italy	41.412	48.442	16.547	53.511	106.025	54.217
Switzerland	0	0	0	0	0	0
Austria	0	0	0	0	0	0
United Kingdom	70.437	142.813	304.860	70.437	142.946	371.967
Ireland	18.396	36.571	91.362	18.396	36.571	175.037
Spain	33.847	36.690	4.754	40.395	78.640	42.365
Portugal	10.150	12.783	3.030	15.539	25.683	25.534

Table C.6: Land Cover Classes [24]

Value	Label
11	Post-flooding or irrigated croplands (or aquatic)
14	Rainfed croplands
20	Mosaic cropland (50-70%) / vegetation (grassland/shrubland/forest) (20-50%)
30	Mosaic vegetation (grassland/shrubland/forest) (50-70%) / cropland (20-50%)
40	Closed to open (>15%) broadleaved evergreen or semi-deciduous forest (>5m)
50	Closed (>40%) broadleaved deciduous forest (>5m)
60	Open (15-40%) broadleaved deciduous forest/woodland (>5m)
70	Closed (>40%) needleleaved evergreen forest (>5m)
90	Open (15-40%) needleleaved deciduous or evergreen forest (>5m)
100	Closed to open (>15%) mixed broadleaved and needleleaved forest (>5m)
110	Mosaic forest or shrubland (50-70%) / grassland (20-50%)
120	Mosaic grassland (50-70%) / forest or shrubland (20-50%)
130	Closed to open (>15%) (broadleaved or needleleaved, evergreen or deciduous) shrubland (<5m)
140	Closed to open (>15%) herbaceous vegetation (grassland, savannas or lichens/mosses)
150	Sparse (<15%) vegetation
160	Closed to open (>15%) broadleaved forest regularly flooded (semi-permanently or temporarily) - Fresh or brackish water
170	Closed (>40%) broadleaved forest or shrubland permanently flooded - Saline or brackish water
180	Closed to open (>15%) grassland or woody vegetation on regularly flooded or waterlogged soil - Fresh, brackish or saline water
190	Artificial surfaces and associated areas (Urban areas >50%)
200	Bare areas
210	Water bodies
220	Permanent snow and ice
230	No data (burnt areas, clouds,...)

Appendix D

Two-cell analysis: Germany & Benelux and France

D.1 Tables

Table D.1: 100% RE system of France and Germany & Benelux with actual line capacity solution.

Cell	WT [5MW_{eq}]				PV [km^2]	
	Onshore	Limit	Onshore	Offshore	Limit	Offshore
Germany & Benelux	32 723	[11085.0 : 137912]	23 839		[1441: 23839]	1 297 [481 : 3 750]
France	2708	[2708 : 220877]	24 579		[2.0 : 24579]	226 [77: 6 532]

Cell	Battery [TWh]	Gas Storage [TWh]	PtG [GW]
Germany & Benelux		1.6	40.6
France		3.4	25.1

Table D.2: RE and storage assets of Germany & Benelux in function of the line capacity.

		No Line	Actual	2x	5x	10x	Limits
WT	Onshore [5MW_{eq}]	39 140	32 723	27 344	15 979	11 085	[11 085 : 137 912]
	Offshore [5MW_{eq}]	23 839	23 839	23 839	23 839	23 839	[1 441. : 23 839]
PV	[km^2]	1 390	1 297	1 062	481	481	[481 : 3 750]
Battery	[TWh]	1.3	1.6	2.1	2.4	0.9	/
Gas storage	[TWh]	36.9	40.6	45.2	54.1	65.5	/
PtG	[GW]	184.2	152.7	116.1	82.0	79.7	/

Table D.3: RE and storage assets of France in function of the line capacity.

		No Line	Actual	2x	5x	10x	Limits
WT	Onshore [5MW_{eq}]	2708	2 708	2 708	7 924	8 629	[2 708 : 220 877]
	Offshore [5MW_{eq}]	23450	24 579	24 579	24 579	24 579	[2 : 24 579]
PV	[km^2]	77	226	645	1 497	1 715	[77 : 6 532]
Battery	[TWh]	3.9	3.4	2.7	2.4	3.8	/
Gas storage	[TWh]	23.7	25.1	29.3	34.7	27.6	/
PtG	[GW]	31.2	38.3	49.6	73.8	72.5	/

Table D.4: RE and storage assets of Germany & Benelux for the four transition scenarios.

		Scenario 1	Scenario 2	Scenario 3	Scenario 4	Limits
WT	Onshore [5MW _{eq}]	11 085	12 018	11 531	32 723	[11 085 : 137 912]
	Offshore [5MW _{eq}]	1 441	1 441	23 839	23 839	[1 441. : 23 839]
PV	[km ²]	481	481	710	1 297	[481 : 3 750]
Battery	[TWh]	/	0	1.8	1.6	/
Gas storage	[TWh]	/	4.8	36.3	40.6	/
PtG	[GW]	/	0	48.4	152.7	/

Table D.5: RE and storage assets of France for the four transition scenarios.

		Scenario 1	Scenario 2	Scenario 3	Scenario 4	Limits
WT	Onshore [5MW _{eq}]	2 708	2 708	2 708	2 708	[2 708 : 220 877]
	Offshore [5MW _{eq}]	2	16 804	24 579	24 579	[2 : 24 579]
PV	[km ²]	77	77	193	226	[77 : 6 532]
Battery	[TWh]	/	2.8	3.4	3.4	/
Gas storage	[TWh]	/	11.2	21	25.1	/
PtG	[GW]	/	0	43.6	38.3	/

D.2 Hourly analysis

In this section, hourly profiles of the energy flows of the two-cell 100% RE electricity system with the actual transmission line capacity are analysed. In Figure D.1 and D.2, hourly production in France and Germany & Benelux are presented for a summer and a winter week respectively. The figures represent a stack of the different production means (in the order Run-of-the-river, Dam, PV, Wind onshore and Wind offshore) followed by the output of the storage systems (in the order CCGT, battery, PHEs) and finally the import from other cells. In addition, a stack of the ways to consume this energy produced is represented with the help of lines. First, the consumption is displayed followed by the input of the storage system (in the order PtG, battery, PHEs). Since no curtailment is observed, the difference between the production stack and the line stack corresponds to the export.

Comparing these two weeks, one can directly notice the strong difference in PV production, which is nearly non-existent in winter and sometimes above consumption during summer in Germany & Benelux.

In Figure D.1, day/night complementarity between the two cells can be observed during the two last days. One can observe that during the day a surplus of PV power is produced in Germany & Benelux. A part of this surplus (limited by the transmission line) is exported to France during the day. On the other hand, during the night, France exports WT production to Germany & Benelux.

Wind turbines can experience high peaks of production. Indeed, it is noticeable that production peaks can be more than two times bigger than consumption in both cells. Looking at the offshore wind production in France, it can be noticed that power sometimes abruptly drop to 0 to come back at rated power a few hours later. This shows the effect of the cut-out wind speed. It can also be noticed that onshore wind does not necessarily reach its cut-out wind speed when offshore does. This shows a complementarity between these two means of production.

Dam power plants are used in France to face mid-term production drops. In Figure D.2, one can see that dams help to supply the load during the mid-term power deficit due to the mid-term decrease in wind production.

Looking at the storage, one can observe that batteries are used for short-term storage and gas storage for mid-term in Germany & Benelux. As can be seen in Figure D.1, during the summer the batteries in Germany & Benelux are used to store the overproduction occurring during the

day due to the solar production and to restore it during the night. When overproduction occurs, the batteries are filled first and then the PtG is used. On the other hand, as can be seen in Figure D.2, after more than one day facing underproduction the gas storage is used in order to cover the consumption. For the same week in France, one can notice that after one day of underproduction the gas storage starts to be used as well. However, the batteries have to be used at the same time, explained by the low power of the CCGT in France as detailed in Section 4.1.5.

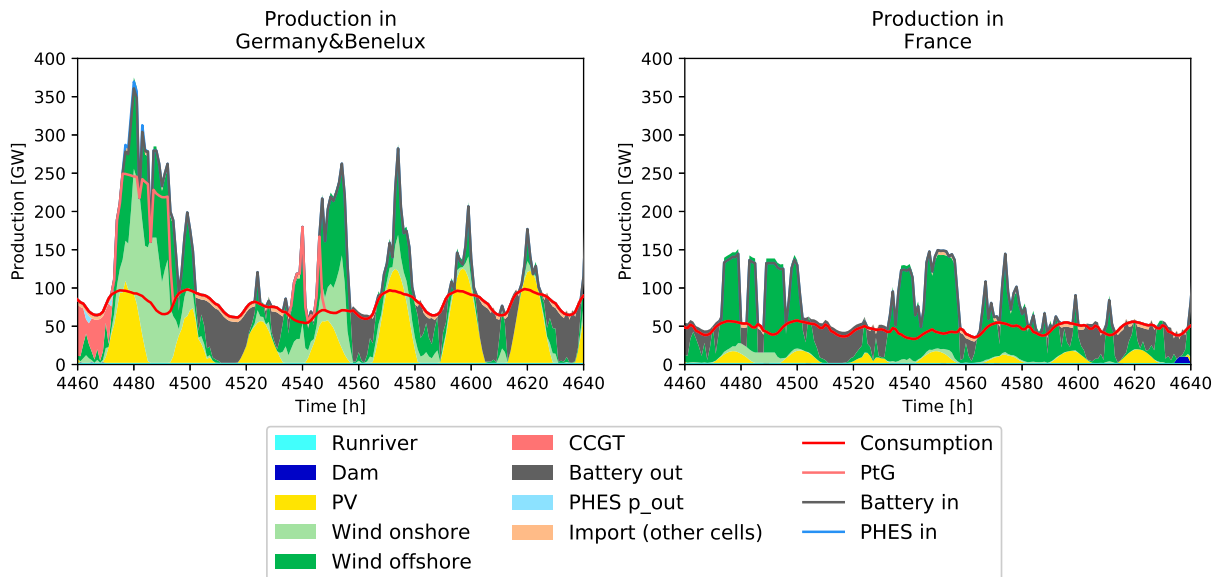

Figure D.1: Hourly production during a summer week

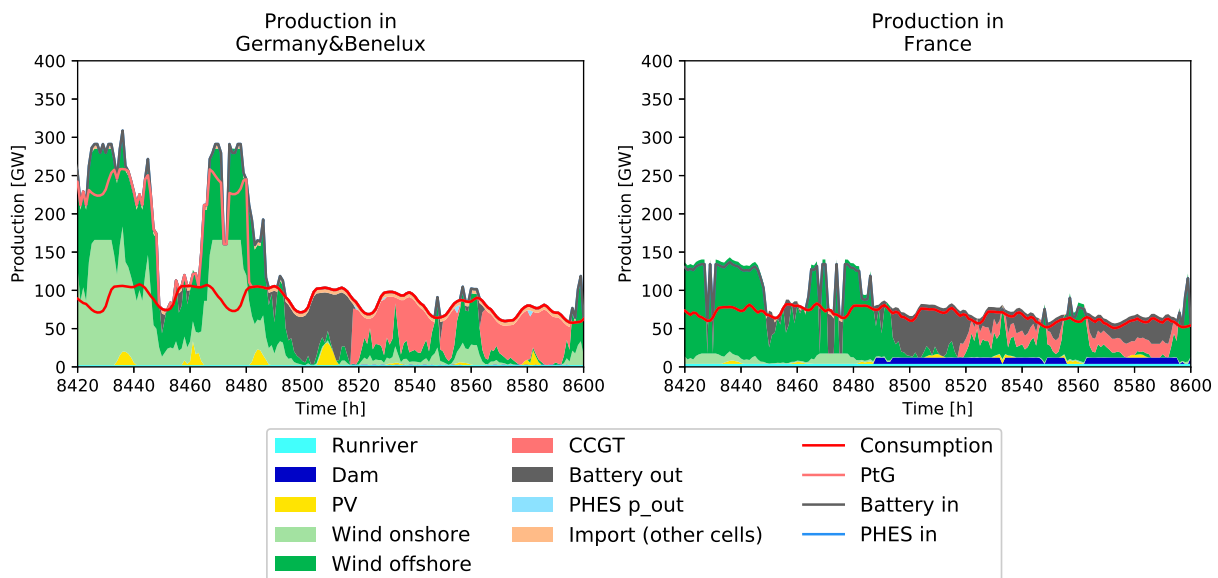

Figure D.2: Hourly production during a winter week

D.3 Study 3: Impact of the RE share

As explained previously, the renewable production share is going to increase in the following years. The renewable sources being often characterised by an intermittent production, storage may play a key role in the electricity system of tomorrow. This study analyses the variation of

the storage and renewable assets in function of the global renewable share for different transition scenarios.

All the inputs of the model are detailed in Chapter 3. As a reminder, the actual production mix of the two cells is presented in Figures D.3 and D.4. One observes that the conventional production mixes are noticeably distinct: Germany & Benelux has an important share of coal but also a significant production from gas and nuclear while France relies mainly only on nuclear. The RE share of Germany & Benelux is equal to 27% with an important wind and biofuel & waste production. The RE share of France is of 19% with an important hydroelectric production share.

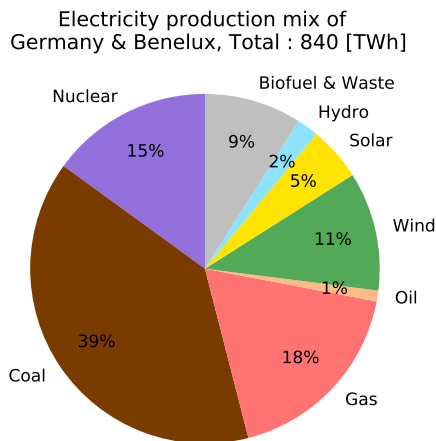

Figure D.3: Electricity production mix of Germany & Benelux of 2017. Adapted from [49, 52, 55, 56].

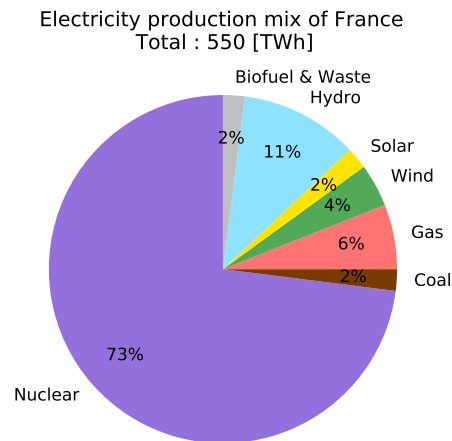

Figure D.4: Electricity production mix of France of 2017. Adapted from [51].

The energy mixes of each case studied are presented in Table D.6. The RE share is expressed as a percentage of the total production and import, while the import share as a percentage of the consumption. The actual line capacity is used. The first case corresponds to the actual energy mix, the RE assets correspond then to the already-installed capacity (see Table C.2) and no storage except PHES is installed. The actual external import of the system is equal to 3% of the consumption ([49, 51, 52, 55, 56]). The second scenario presents the society in 15-25 years with 50% of renewable production, with an electricity import of 3% of the consumption and the installed capacities of the nuclear and coal centrals divided by two for each cell. The third scenario presents a speculative case with 90% of total RE production, with no import and no more nuclear or coal production. The last scenario corresponds to a 100% RE system with no external import, which is thus identical to the case presented in Study 1. Only the global RE share of the system is fixed, the RE share of each cell is free. In each scenario, the gas import is not limited. The system can thus import as much gas as necessary while respecting the RE share constraint. The electricity import capacity of the cells, not including the exchange capacity between them, is 7.2 GW and 8.2 GW for France and Germany & Benelux respectively, as mentioned in Figure 3.15 while the exchange capacity from France to Germany & Benelux is 6.1 GW and from Germany & Benelux to France 5.6 GW.

Table D.6: Study cases.

Case	RE [%]	Import [%]	Installed capacity	
			[% of actual capacity]	
			Nuclear	Coal
1.	24	3	100	100
2.	50	3	50	50
3.	90	0	0	0
4.	100	0	0	0

In the following subsections, the impact of the RE share on the RE and storage assets of the system is analysed.

D.3.1 Renewable assets

In Figures D.5 and D.6, one can observe the RE installed capacities in function of the RE share for Germany & Benelux and France, respectively. A summary of the solutions for the RE and storage assets of the different cases is presented in Tables D.4 and D.5.

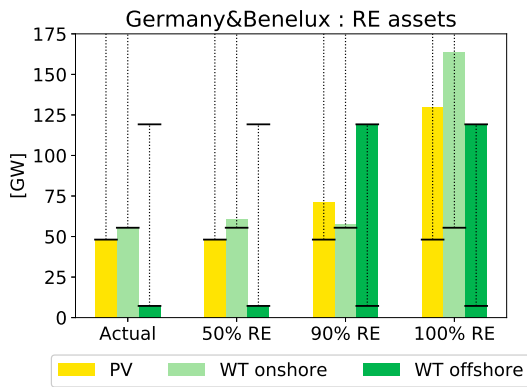

Figure D.5: Renewable assets in function of the RE share in Germany & Benelux.

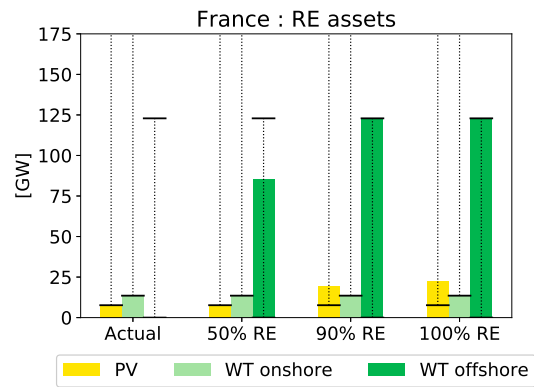

Figure D.6: Renewable assets in function of RE share in France.

In the 50% RE scenario, France only installs new offshore WTs. Indeed, France offshore wind presents the highest EROI. Since the system is at low RE share, intermittent production is still well absorbed by the consumption. The system then follows a merit order and provides the needed extra RE share using France offshore wind. Germany also installs a small amount of additional onshore WTs. Similar to France, the best EROI technology is installed, that is to say onshore wind. The RE production share of France is at 83.0% compared to 29.1% for Germany & Benelux (see Table D.7). This is explained by the better EROI of the offshore WTs of France.

When the system has to reach 90% of RE production, a clear merit order is no more observed. France reaches the upper of offshore WTs and installs PV panels, presenting a lower EROI than onshore WT. Looking at Germany, the small amount of onshore WTs previously installed is replaced by offshore WTs and PV panels. These two assets have lower EROIs but are better absorbed by consumption as previously mentioned. Since RE share is high, well-absorbed production means are preferred in order to lower storage needs and losses, as seen in the previous study.

Finally, to reach a 100% RE system, an import increase of the RE assets is observed in Germany & Benelux. This can be understood by looking at Table D.7 which represents the RE share in both cells for each scenario. One can observe that in the 90% RE scenario France RE

share is nearly already at 100% while the one of Germany & Benelux is only at 82%, explained by the better EROI of the RE assets of France. Then, to reach a 100% RE system, Germany & Benelux has to increase strongly its RE production, when France nearly does not change its installed means of production. This leads to a high increase of the PV panels and onshore WTs installed capacity of Germany & Benelux.

Table D.7: RE share in Germany & Benelux and France for each scenario.

Total	Germany & Benelux	France
24% RE	27.0%	19.0%
50% RE	29.1%	83.0%
90% RE	82.0%	99.7%
100% RE	100.0%	100.0%

D.3.2 Storage assets

In Figure D.7 and D.8, battery and PtG installed capacity are represented, respectively.

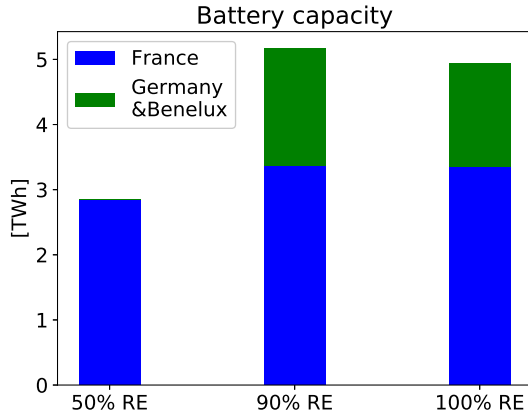

Figure D.7: Battery capacity in function of RE share in France and Germany & Benelux.

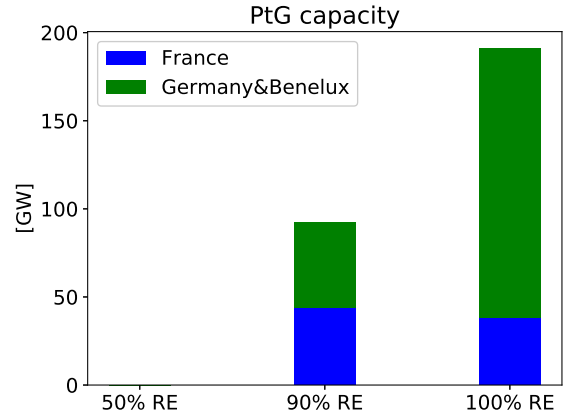

Figure D.8: PtG capacity in function of RE share in France and Germany & Benelux.

In the first case, with a 50% RE system, only France installs batteries. This comes from the fact that France has a higher share of renewable than Germany & Benelux, as seen in Table D.7, and that Germany & Benelux has a more important flexible generation capacity. Indeed, in the 50% RE scenario, CCGT and coal in Germany represent 118% of its average power consumption, when in France it corresponds to 36% of its average power consumption. Indeed, the major power source of France is the nuclear which has been considered as non-flexible. As seen in Table D.7, France has a 83% renewable production, compared to less than 30% in Germany. The stronger intermittency of the production of France also explains its battery needs. It is interesting to notice that no PtG is needed. However, even without PtG, seasonal storage is already implemented in France as can be seen in Figure D.10, due to its consumption profile (see Figure 4.1). The gas stored corresponds to gas imported. As can be seen in Figure D.9, Germany & Benelux storage does not present a seasonal shape.

In the 90% RE scenario, France installs PtG. This comes from the seasonal shape of the French consumption and production. France needs to store its wind power during summer to use it during winter. In Germany & Benelux, conventional production replaced by a high offshore WT capacity and PV induces a need in storage. Batteries are used as short-term storage, when

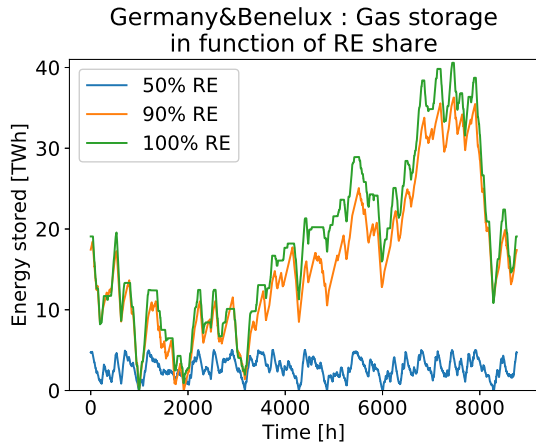

Figure D.9: Gas storage in function of time for different RE share scenario in Germany&Benelux.

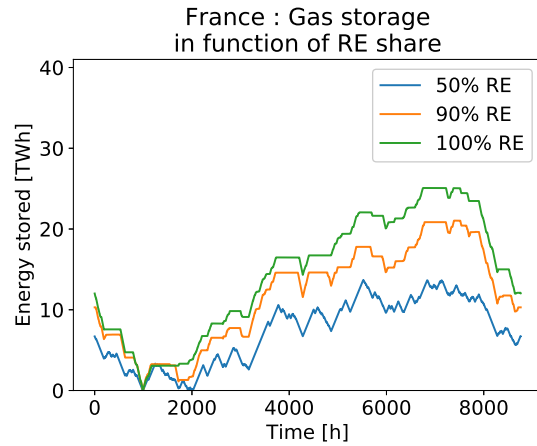

Figure D.10: Gas storage in function of time for different RE share scenario in France.

PtG is used for seasonal storage.

Finally, for the 100% RE case, no major changes are observed in France since the RE assets are nearly the same as in the previous scenario. In Germany & Benelux, the PtG capacity is tripled from the previous case. It is induced by the high increase in installed RE capacity, forcing to install mid-term and long-term storage means. It is noticeable in Figure D.7 that a slight decrease in Germany & Benelux battery storage occurs. It is due to the high PtG installed capacity, allowing to absorb higher RE peaks than previously. The system then decides to lower its investment in batteries to transfer mid-term storage to the PtG.

D.3.3 Conclusion

The transition scenarios studied highlight the usefulness of flexible means of production. Indeed, they allow to limit the storage needs while increasing the RE shares. It is also observed that, by imposing a RE share constraint at the scale of the system and not of the cell, the cell with the renewable assets presenting the highest EROIs produces most of the RE energy needed during the transition. This induces a severe step of RE assets for the other cell while passing from 90 to 100% RE. However, this is a theoretical case. In practise, it is more likely that countries will install renewable assets more or less simultaneously.

Appendix E

Six-cell analysis: Western Europe

E.1 Tables

Table E.1: Results of the 100% RE Western Europe system with actual line capacity.

Cell	WT [5MW _{eq}]				PV [km ²]	
	Onshore	Limit Onshore	Offshore	Limit Offshore	Inst.	Limit
Scandinavia	7525	[2413 : 234654]	1813	[294 : 72936]	7	[7 : 5 590]
British Isles	46 741	[2956.2 : 159236]	1277	[1277 : 111183]	127	[127 : 4 461]
Germany & Benelux	25 896	[11085.0 : 137912]	23 839	[1441: 23839]	1 198	[481 : 3 750]
France	2708	[2708 : 220877]	24 579	[2.0 : 24579]	349	[77: 6 532]
Italy and Alpine states	28 714	[2436 : 144689]	0	[0 : 10404]	1 129	[213 : 3 956]
Iberian Peninsula	21 249	[5581: 227230]	1	[1.0 : 7970]	949	[72 : 6 565]
Cell	Batteries [TWh]		Gas Storage [TWh]		PtG [GW]	
Scandinavia	0.009		0.06		0.07	
British Isles	0.6		36.3		179.8	
Germany & Benelux	1.0		37.5		141.1	
France	2.7		26.1		41.4	
Italy and Alpine states	0.3		25.8		77.2	
Iberian Peninsula	0.3		26.2		82.7	

Table E.2: Results of the 100% RE Western Europe system with actual and double line capacity.

Cell	WT Onshore [5MW _{eq}]			WT Offshore [5MW _{eq}]			PV [km ²]		
	1x	2x	Limit	1x	2x	Limit	1x	2x	Limit
Scandinavia	7525	7 497	[2 413 : 234 654]	1 813	2 537	[294 : 72 936]	7	7	[7 : 5 590]
British Isles	46 741	48 494	[2 956 : 159 236]	1 277	1 277	[1 277 : 111 183]	127	127	[127 : 4 461]
Germany & Benelux	25 896	13 391	[11 085 : 137 912]	23 839	23 839	[1 441: 23 839]	1 198	846	[481 : 3 750]
France	2 708	2 708	[2 708 : 220 877]	24 579	24 579	[2 : 24 579]	349	574	[77: 6 532]
Italy and Alpine states	28 714	31 018	[2 436 : 144 689]	0	0	[0 : 10 404]	1 129	1 287	[213 : 3 956]
Iberian Peninsula	21 249	23 383	[5 581: 227 230]	1	1	[1 : 7 970]	949	1 063	[72 : 6 565]
Cell	Battery [TWh]			Gas Storage [TWh]			PtG [GW]		
	1x	2x	Limit	1x	2x	Limit	1x	2x	Limit
Scandinavia	0.009	0.01	/	0.06	0.5	/	0.07	0.6	/
British Isles	0.6	0.6	/	36.3	38.0	/	179.8	184.5	/
Germany & Benelux	1.0	0.9	/	37.5	36.8	/	141.1	100.2	/
France	2.7	1.6	/	26.1	25.6	/	41.4	50.2	/
Italy and Alpine states	0.3	0.3	/	25.8	31.6	/	77.2	99.2	/
Iberian Peninsula	0.3	0.3	/	26.2	28.4	/	82.7	94.2	/

E.2 Graphs

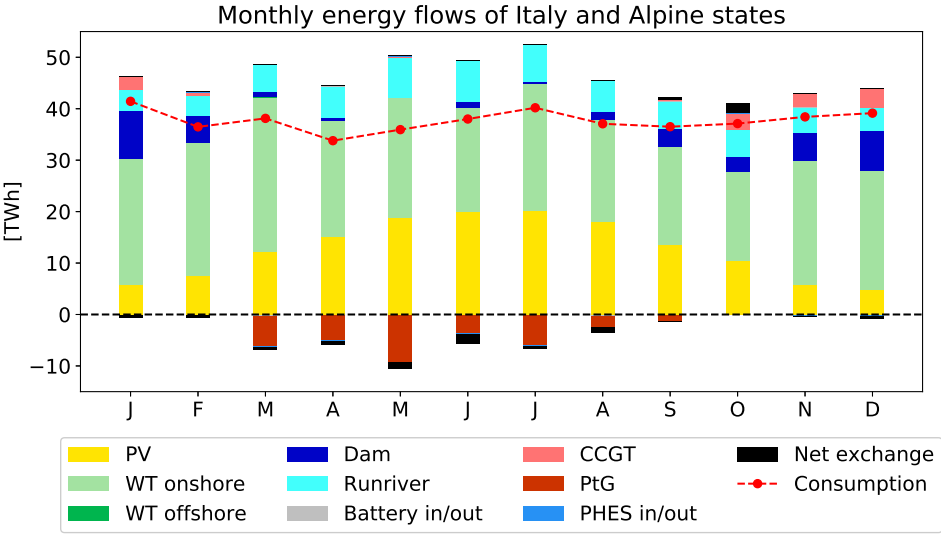

Figure E.1: Italy and Alpine states monthly production and consumption [TWh].

Bibliography

- [1] Tino Aboumahboub et al. “Investigating optimal configuration of a prospective renewable-based electricity supply sector”. In: *energy* 5 (2010), p. 6.
- [2] Ademe. *Vers un mix électrique 100% renouvelable en 2050*. URL: <http://www.ademe.fr/mix-electrique-100-renouvelable-analyses-optimisations> (visited on 06/04/2018).
- [3] International Energy Agency. URL: <https://www.iea.org/> (visited on 04/08/2018).
- [4] International Energy Agency. *IEA Wind TCP 2016 Annual Report*. URL: <https://community.ieawind.org/publications/ar> (visited on 05/26/2018).
- [5] Piergiorgio Alotto, Massimo Guarnieri, and Federico Moro. “Redox flow batteries for the storage of renewable energy: A review”. In: *Renewable and Sustainable Energy Reviews* 29 (2014), pp. 325–335.
- [6] Kerstine Appunn. *Re-dispatch costs in the German power grid*. 2016. URL: <https://www.cleanenergywire.org/factsheets/re-dispatch-costs-german-power-grid> (visited on 05/26/2018).
- [7] Kerstine Appunn. *The history behind Germany’s nuclear phase-out*. 2018. URL: <https://www.cleanenergywire.org/factsheets/history-behind-germanys-nuclear-phase-out> (visited on 06/03/2018).
- [8] Danish Wind Industry Association. *The Danish Market Statistics on the development of wind power in Denmark 2005-2016*. URL: http://www.windpower.org/en/knowledge/statistics/the%5C_danish%5C_market.html (visited on 05/10/2018).
- [9] European Wind Energy Association. *Deep water, The next step for offshore wind energy*. 2013. URL: https://windeurope.org/fileadmin/files/library/publications/reports/Deep_Water.pdf (visited on 05/26/2018).
- [10] World Nuclear Association. *Nuclear Power in France*. URL: <http://www.world-nuclear.org/information-library/country-profiles/countries-a-f/france.aspx> (visited on 05/18/2018).
- [11] Charles J Barnhart and Sally M Benson. “On the importance of reducing the energetic and material demands of electrical energy storage”. In: *Energy & Environmental Science* 6.4 (2013), pp. 1083–1092.
- [12] Markus Biberacher. “Modelling and optimisation of future energy systems using spatial and temporal methods”. In: (2007).
- [13] Lori Bird, Jaquelin Cochran, and Xi Wang. *Wind and solar energy curtailment: Experience and practices in the United States*. Tech. rep. National Renewable Energy Laboratory (NREL), Golden, CO., 2014.
- [14] Leticia Blázquez, Nina Boogen, and Massimo Filippini. “Residential electricity demand in Spain: new empirical evidence using aggregate data”. In: *Energy economics* 36 (2013), pp. 648–657.
- [15] Anne Sjoerd Brouwer et al. “Least-cost options for integrating intermittent renewables in low-carbon power systems”. In: *Applied Energy* 161 (2016), pp. 48–74.

- [16] Alexander Buttler et al. “Variability of wind and solar power—An assessment of the current situation in the European Union based on the year 2014”. In: *Energy* 106 (2016), pp. 147–161.
- [17] Commissariat à l’énergie atomique et aux énergies alternatives (CEA). *Centre de Cadarache*. URL: <http://cadarache.cea.fr/cad/Pages/Accueil.aspx> (visited on 06/07/2018).
- [18] Global Runoff Data Centre. *Long-Term Statistics and Annual Characteristics of GRDC Timeseries Data*. URL: http://www.bafg.de/GRDC/EN/03_dtprdcts/32_LTMM/longtermstat_node.html (visited on 05/10/2018).
- [19] European Commission. *Electricity interconnection targets*. URL: <https://ec.europa.eu/energy/en/topics/infrastructure/projects-common-interest/electricity-interconnection-targets> (visited on 05/12/2018).
- [20] European Commission. *2050 low-carbon economy*. URL: https://ec.europa.eu/clima/policies/strategies/2050_en (visited on 06/06/2018).
- [21] European Commission. *Energy roadmap 2050*. URL: https://ec.europa.eu/energy/sites/ener/files/documents/2012_energy_roadmap_2050_en_0.pdf (visited on 06/09/2018).
- [22] David Connolly and Brian Vad Mathiesen. “A technical and economic analysis of one potential pathway to a 100% renewable energy system”. In: *International Journal of Sustainable Energy Planning and Management* 1 (2014), pp. 7–28.
- [23] Energy & Industrial Strategy Department for Business. *National Statistics Solar photovoltaics deployment*. 2018. URL: <https://www.gov.uk/government/statistics/solar-photovoltaics-deployment> (visited on 05/10/2018).
- [24] Elise Dupont, Rembrandt Koppelaar, and Hervé Jeanmart. “Global available wind energy with physical and energy return on investment constraints”. In: *Applied Energy* 209 (2018), pp. 322–338.
- [25] SONI EirGrid. “All-island generation capacity statement 2017-2026”. In: *EirGrid and System Operator of Northern Ireland (SONI)* (2017).
- [26] Elia. *Transmission capacity at borders, Calculation-methods*. URL: <http://www.elia.be/en/products-and-services/cross-border-mechanisms/transmission-capacity-at-borders/calculation-methods#anchor3> (visited on 06/04/2018).
- [27] Agora Energiewende. “Electricity storage in the German energy transition”. In: *Agora Energ., Berlin, Ger. Article Locations: Article Location Article Location* (2014).
- [28] ENTSO-E. *ENTSO-E NTC archives*. URL: <https://www.entsoe.eu/publications/market-reports/#ntc-values---intro-to-the-ntc-matrix> (visited on 05/04/2018).
- [29] ENTSO-E. *ENTSO-E Power Statistics*. URL: <https://www.entsoe.eu/data/power-stats/> (visited on 05/06/2018).
- [30] ENTSO-E. *ENTSO-E Transmission System Map*. URL: <https://www.entsoe.eu/data/map/> (visited on 05/04/2018).
- [31] ENTSOE. *ENTSOE Transparency Platform*. URL: <https://transparency.entsoe.eu/> (visited on 05/17/2018).
- [32] ENTSOE. *Mid-term adequacy forecast*. URL: https://docstore.entsoe.eu/Documents/SDC%5C%20documents/MAF/MAF_2017_report_for_consultation.pdf (visited on 06/09/2018).
- [33] ENTSOE. *Winter outlook report 2016/2017 and summer review 2016*. URL: https://docstore.entsoe.eu/Documents/Publications/SDC/2016-wor_report.pdf (visited on 05/17/2018).

- [34] The Crown Estate. *Offshore wind operational report*. URL: https://www.thecrownestate.co.uk/media/1050888/operationalwindreport2017_final.pdf (visited on 05/17/2018).
- [35] Wind Europe. *European wind energy generation*. URL: <https://windeurope.org/wp-content/uploads/files/about-wind/daily-wind/daily-wind-first-half-2017.pdf> (visited on 05/17/2018).
- [36] Wind Europe. *Offshore Wind in Europe : Key trends and statistics 2017*. URL: <https://windeurope.org/wp-content/uploads/files/about-wind/statistics/WindEurope-Annual-Offshore-Statistics-2017.pdf> (visited on 05/17/2018).
- [37] Wind Europe. “The European offshore wind industry—Key trends and statistics 2017”. In: *Wind Europe: Brussels, Belgium* (2018), p. 37.
- [38] Jean Pierre Frau. “Tidal energy: promising projects: La Rance, a successful industrial-scale experiment”. In: *IEEE Transactions on Energy Conversion* 8.3 (1993), pp. 552–558.
- [39] Vasilis M Fthenakis. “End-of-life management and recycling of PV modules”. In: *Energy Policy* 28.14 (2000), pp. 1051–1058.
- [40] Frederik Geth et al. “An overview of large-scale stationary electricity storage plants in Europe: current status and new developments”. In: *Renewable and Sustainable Energy Reviews* 52 (2015), pp. 1212–1227.
- [41] Yashar Ghiassi-Farrokhfal, Srinivasan Keshav, and Catherine Rosenberg. “An EROI-based analysis of renewable energy farms with storage”. In: *Proceedings of the 5th international conference on Future energy systems*. ACM. 2014, pp. 3–13.
- [42] Marcos Gimeno-Gutiérrez and Roberto Lacal-Arantequi. “Assessment of the European potential for pumped hydropower energy storage”. In: *A GIS-based assessment of pumped hydropower storage potential. EUR, Scientific and technical research series* 25940 (2013).
- [43] Charles AS Hall. “Will EROI be the Primary Determinant of Our Economic Future? The View of the Natural Scientist versus the Economist”. In: *Joule* 1.4 (2017), pp. 635–638.
- [44] Charles AS Hall, Stephen Balogh, and David JR Murphy. “What is the minimum EROI that a sustainable society must have?” In: *Energies* 2.1 (2009), pp. 25–47.
- [45] Ric Hoefnagels et al. *Long Term Potentials and Costs of RES Online database*. URL: <http://www.green-x.at/RS-potentials-overview.php> (visited on 05/04/2018).
- [46] Monique Maria Hoogwijk. “On the global and regional potential of renewable energy sources”. PhD thesis. 2004.
- [47] Stefan Pfenninger Iain Staffell. *Renewables Ninja*. URL: <https://www.renewables.ninja/> (visited on 05/10/2018).
- [48] IEA. *Austria - Energy System Overview*. URL: <https://www.iea.org/media/countries/Austria.pdf> (visited on 05/10/2018).
- [49] IEA. *Belgium - Energy System Overview*. URL: <https://www.iea.org/media/countries/Belgium.pdf> (visited on 05/10/2018).
- [50] IEA. *Denmark - Energy System Overview*. URL: <https://www.iea.org/media/countries/Denmark.pdf> (visited on 05/10/2018).
- [51] IEA. *France - Energy System Overview*. URL: <https://www.iea.org/media/countries/France.pdf> (visited on 05/10/2018).
- [52] IEA. *Germany - Energy System Overview*. URL: <https://www.iea.org/media/countries/Germany.pdf> (visited on 05/10/2018).
- [53] IEA. *Ireland - Energy System Overview*. URL: <https://www.iea.org/media/countries/Ireland.pdf> (visited on 05/10/2018).

- [54] IEA. *Italy - Energy System Overview*. URL: <https://www.iea.org/media/countries/Italy.pdf> (visited on 05/10/2018).
- [55] IEA. *Luxembourg - Energy System Overview*. URL: <https://www.iea.org/media/countries/Luxembourg.pdf> (visited on 05/10/2018).
- [56] IEA. *Netherlands - Energy System Overview*. URL: <https://www.iea.org/media/countries/Netherlands.pdf> (visited on 05/10/2018).
- [57] IEA. *Norway - Energy System Overview*. URL: <https://www.iea.org/media/countries/Norway.pdf> (visited on 05/10/2018).
- [58] IEA. *Portugal - Energy System Overview*. URL: <https://www.iea.org/media/countries/Portugal.pdf> (visited on 05/10/2018).
- [59] IEA. *Spain - Energy System Overview*. URL: <https://www.iea.org/media/countries/Spain.pdf> (visited on 05/10/2018).
- [60] IEA. *Sweden - Energy System Overview*. URL: <https://www.iea.org/media/countries/Sweden.pdf> (visited on 05/10/2018).
- [61] IEA. *Switzerland - Energy System Overview*. URL: <https://www.iea.org/media/countries/Switzerland.pdf> (visited on 05/10/2018).
- [62] IEA. *United Kingdom - Energy System Overview*. URL: <https://www.iea.org/media/countries/UnitedKingdom.pdf> (visited on 05/10/2018).
- [63] Mareike Jentsch, Tobias Trost, and Michael Sterner. “Optimal use of power-to-gas energy storage systems in an 85% renewable energy scenario”. In: *Energy Procedia* 46 (2014), pp. 254–261.
- [64] Jason Jonkman et al. *Definition of a 5-MW reference wind turbine for offshore system development*. Tech. rep. National Renewable Energy Lab.(NREL), Golden, CO (United States), 2009.
- [65] T Klaus et al. “Energy target 2050: 100% renewable electricity supply”. In: *Federal Environment Agency of Germany, Dessau-Roßlau* (2010).
- [66] Fred Lambert. *Tesla quietly brings online its massive – biggest in the world – 80 MWh Powerpack station with Southern California Edison*. URL: <https://electrek.co/2017/01/23/tesla-mira-loma-powerpack-station-southern-california-edison/> (visited on 06/09/2018).
- [67] Jessica G Lambert et al. “Energy, EROI and quality of life”. In: *Energy Policy* 64 (2014), pp. 153–167.
- [68] Jessica Lambert et al. “EROI of global energy resources: preliminary status and trends”. In: *State University of New York, College of Environmental Science and Forestry* (2012).
- [69] Bernhard Lehner, Gregor Czisch, and Sara Vassolo. “Europe’s hydropower potential today and in the future”. In: *EuroWasser: Model-based Assessment of European Water Resources and Hydrology in the Face of Global Change. Chapter8, Kassel* (2001).
- [70] A. Lelièvre. “Le radiateur électrique, l’autre exception française”. In: *Les Echos* (). URL: https://www.lesechos.fr/25/01/2017/lesechos.fr/0211703876444_le-radiateur-electrique--l-autre-exception-francaise.htm.
- [71] Gauthier Limpens and Hervé Jeanmart. “Electricity storage needs for the energy transition: An EROI based analysis illustrated by the case of Belgium”. In: *Energy* (2018).
- [72] Brian Vad Mathiesen et al. “Smart Energy Systems for coherent 100% renewable energy and transport solutions”. In: *Applied Energy* 145 (2015), pp. 139–154.
- [73] METEONORM. *n.d. Global Meteorological Database for Engineers, Planners and Education*. URL: www.meteonorm.com (visited on 05/15/2018).

- [74] H Muller-Steinhagen and F Trieb. “Concentrating solar power,-A review of the technology”. In: *Ingenia* 18 (2004), pp. 43–50.
- [75] David J Murphy and Charles AS Hall. “Year in review—EROI or energy return on (energy) invested”. In: *Annals of the New York Academy of Sciences* 1185.1 (2010), pp. 102–118.
- [76] NREL. *Concentration Solar Power Projects*. URL: https://www.nrel.gov/csp/solarpaces/project_detail.cfm/projectID=229 (visited on 06/05/2018).
- [77] NREL. *Renewable Electricity Futures Study*. URL: <https://www.nrel.gov/analysis/re-futures.html> (visited on 06/04/2018).
- [78] ER Observ. “Photovoltaic barometer”. In: *Systemes Solaires. Le Journal du Photovoltaïque* (2014), pp. 60–81.
- [79] ofgem. *Electricity interconnectors*. URL: <https://www.ofgem.gov.uk/electricity/transmission-networks/electricity-interconnectors> (visited on 05/15/2018).
- [80] Jenni Patronen, Eeva Kaura, and Cathrine Torvestad. *Nordic heating and cooling: Nordic approach to EU’s Heating and Cooling Strategy*. Nordic Council of Ministers, 2017.
- [81] The Wind Power. *The Wind Power database*. URL: https://www.thewindpower.net/statistics_en.php (visited on 05/10/2018).
- [82] IEA PVPS. “Survey Report of Selected IEA Countries between 1992 and 2015”. In: *T1–30* (2016).
- [83] renewableUK. *UK Wind Energy Database (UKWED)*. URL: <http://www.renewableuk.com/page/UKWEDhome> (visited on 05/10/2018).
- [84] Pierre Schlosser and Arta Denina. *Hydro in europe: Powering renewables*. 2011.
- [85] Yvonne Scholz, Hans Christian Gils, and Robert C Pietzcker. “Application of a high-detail energy system model to derive power sector characteristics at high wind and solar shares”. In: *Energy Economics* 64 (2017), pp. 568–582.
- [86] Iain Staffell and Stefan Pfenninger. “Using bias-corrected reanalysis to simulate current and future wind power output”. In: *Energy* 114 (2016), pp. 1224–1239.
- [87] European Commission Expert Group on electricity interconnection targets. *Towards a sustainable and integrated Europe*. 2017.
- [88] Tesla. *Tesla Powerpack, Spécifications générales du système*. URL: https://www.tesla.com/fr_BE/powerpack (visited on 06/05/2018).
- [89] Ib Troen and Erik Lundtang Petersen. *European Wind Atlas*. Risø National Laboratory, 1989. ISBN: 87-550-1482-8.

