

## APPENDIX L

---

# PROTOTYPE: DRAWINGS

---

This section presents the drawings used to manufacture the different parts of the prototype. In the order, the reader will find:

1. The yoke;
2. The first back iron;
3. The second back iron;
4. The lids;
5. The protective shield;
6. The sleeve;
7. The tube between the protective shield and the stand;
8. The mounting bracket.

# L.1 Yoke

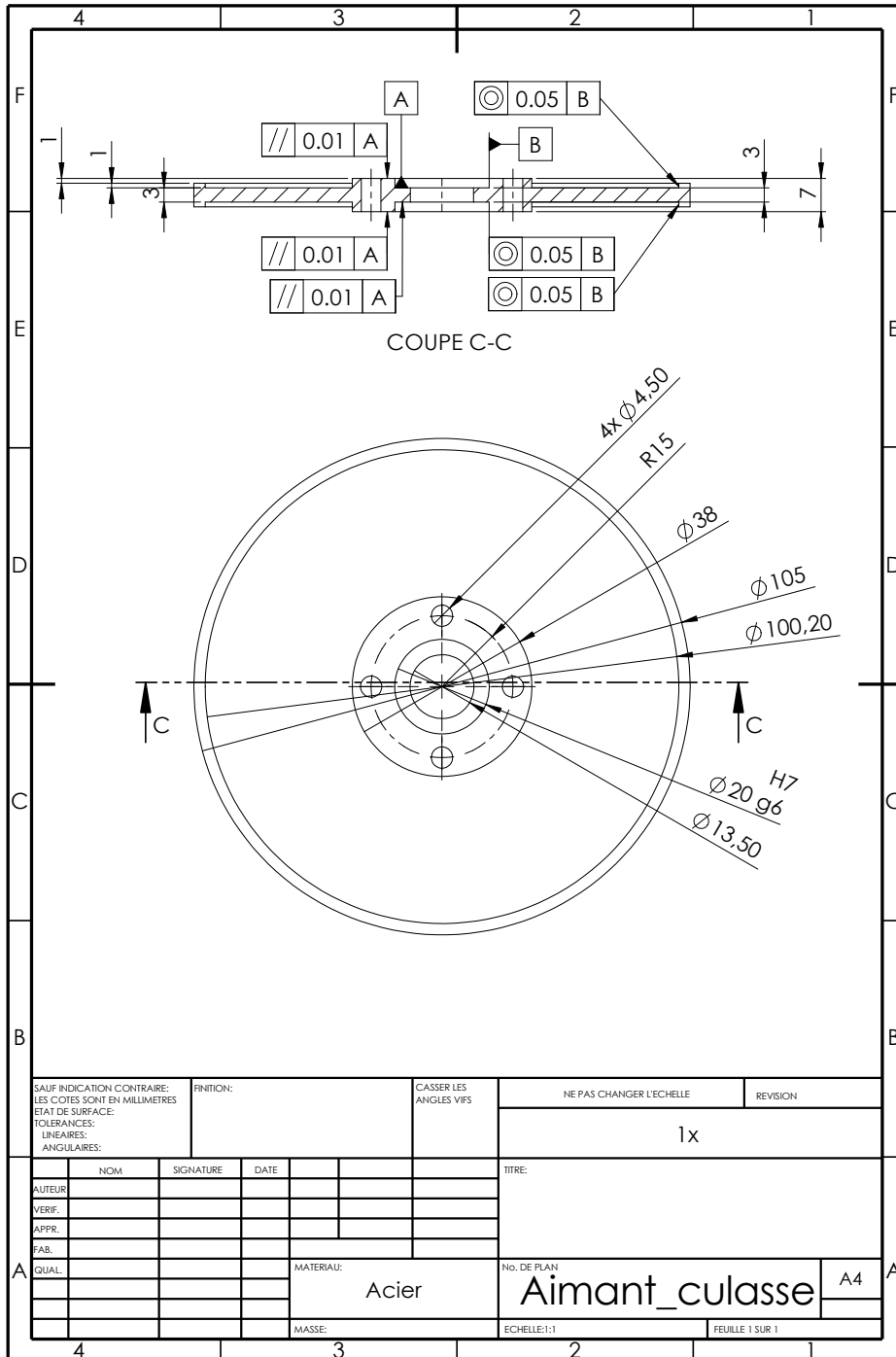

## L.2 First back iron

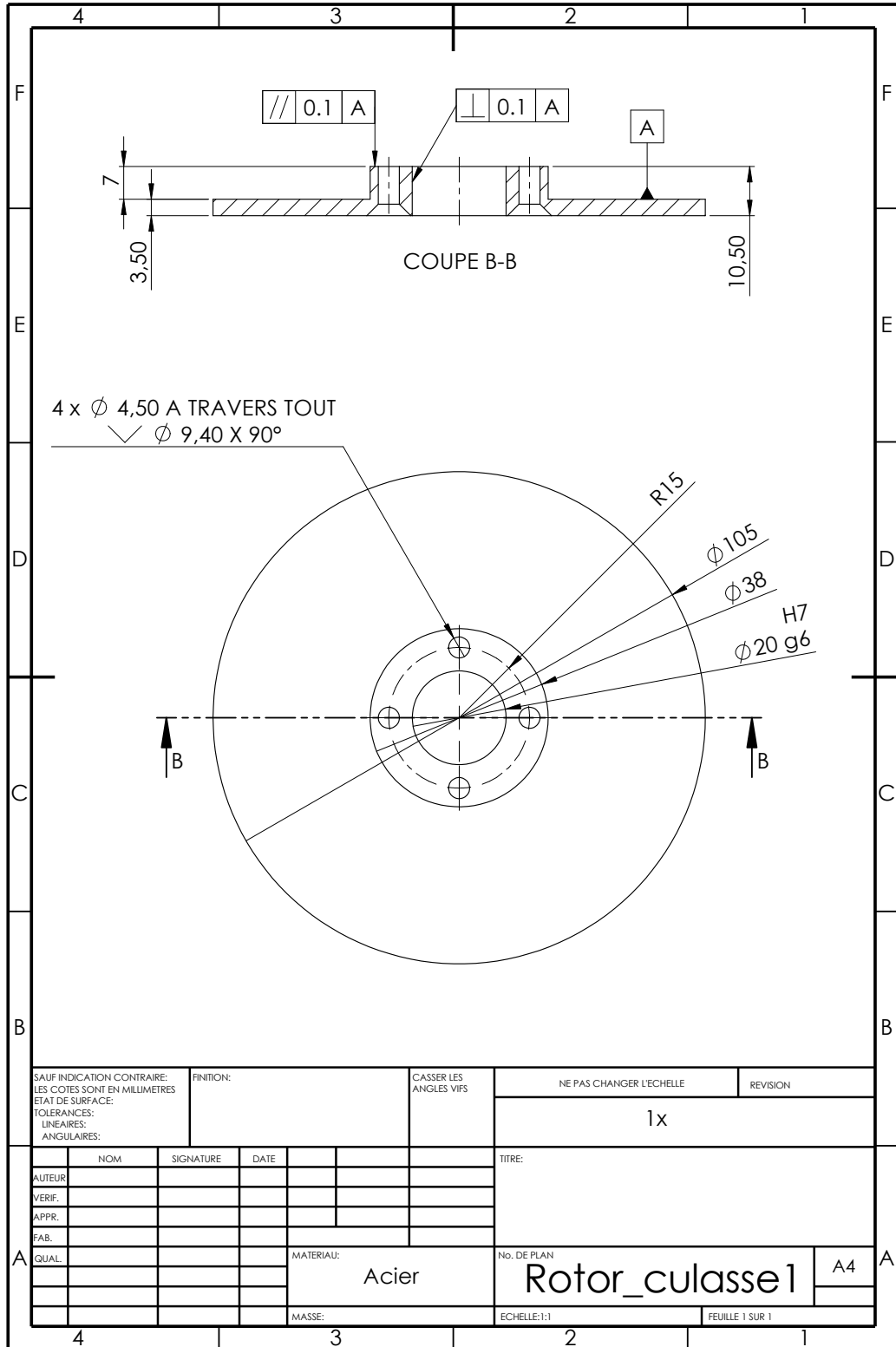



## L.4 Lids

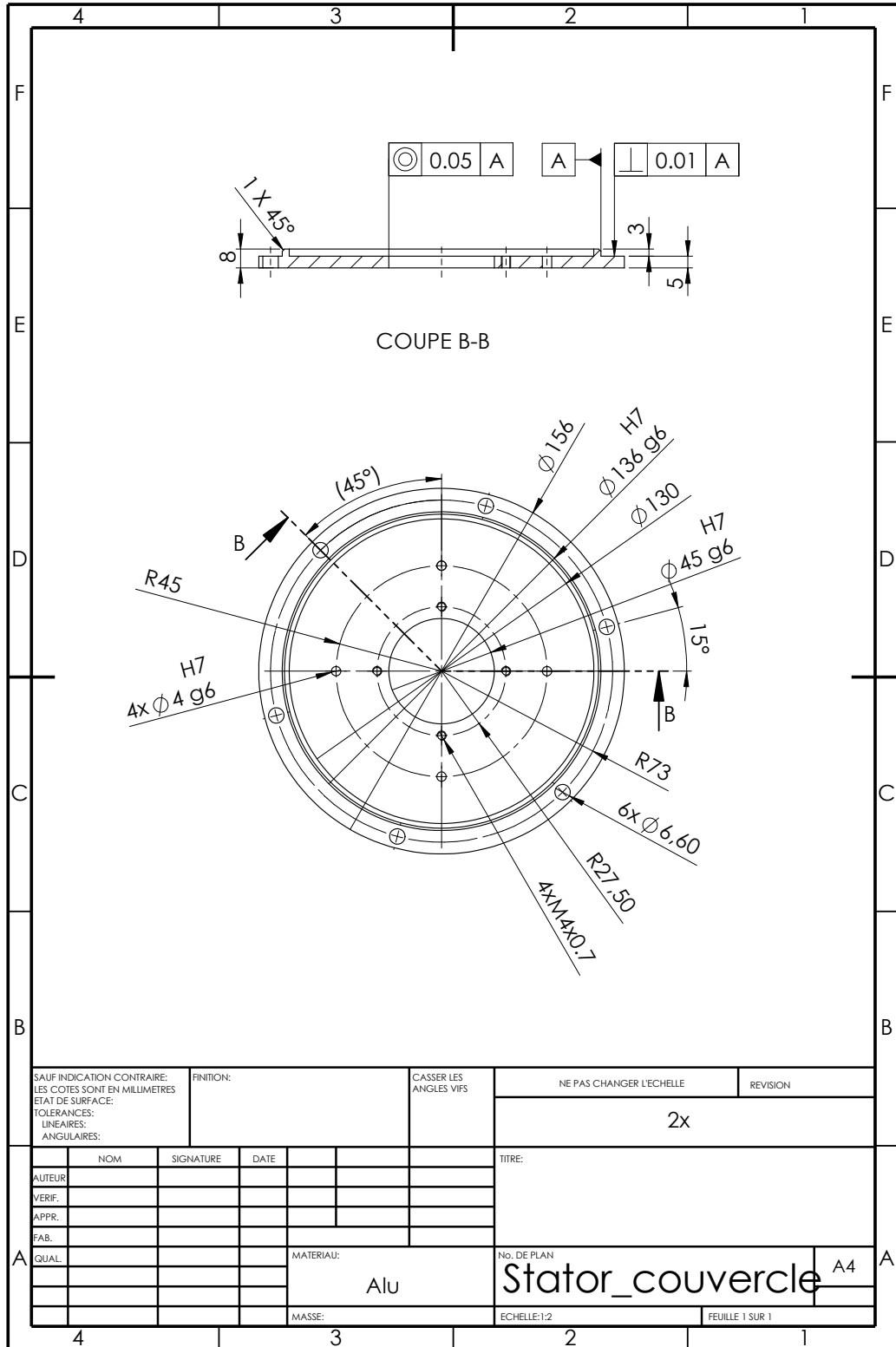

# L.5 Protective shield

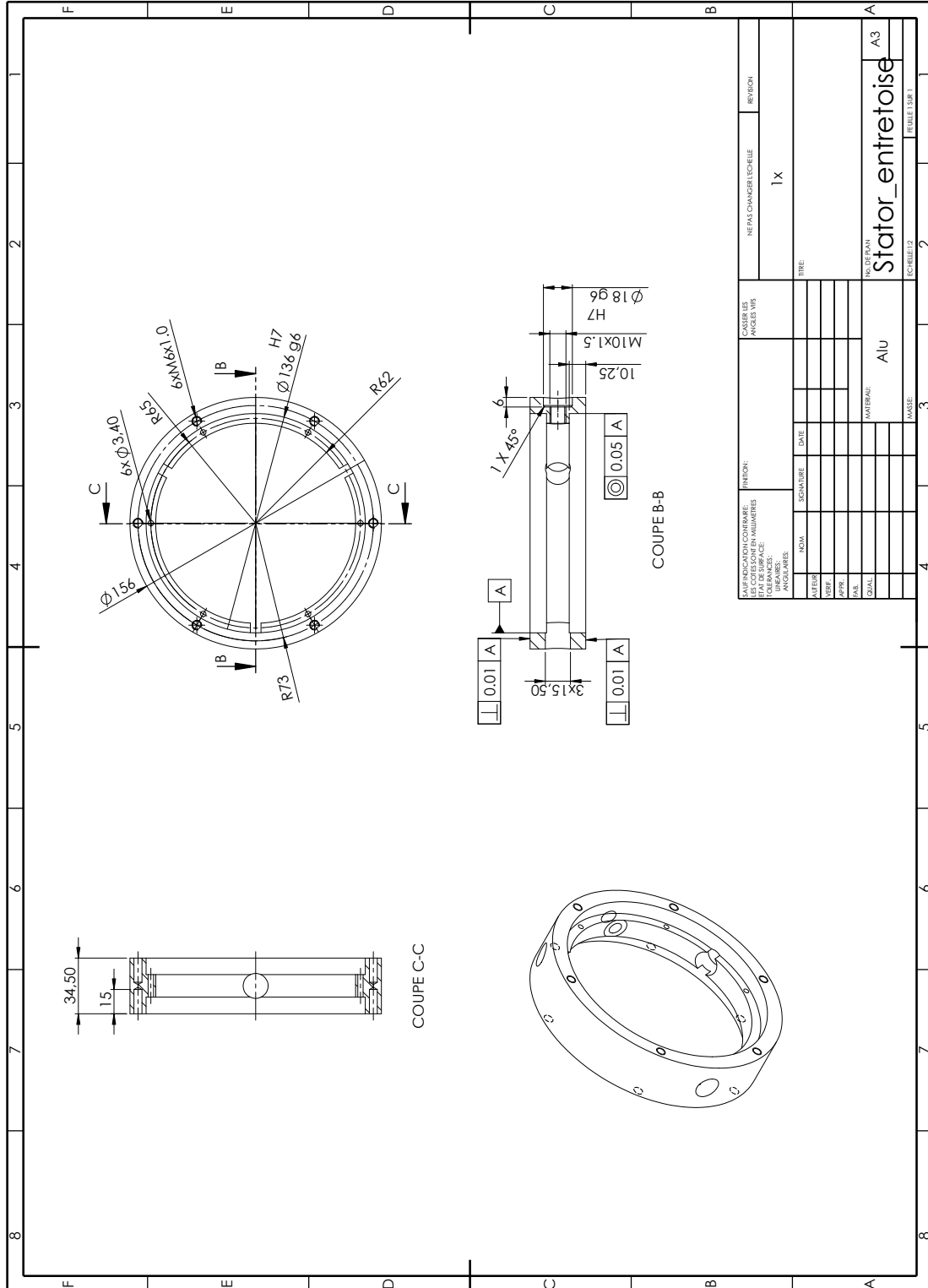

# L.6 Sleeve

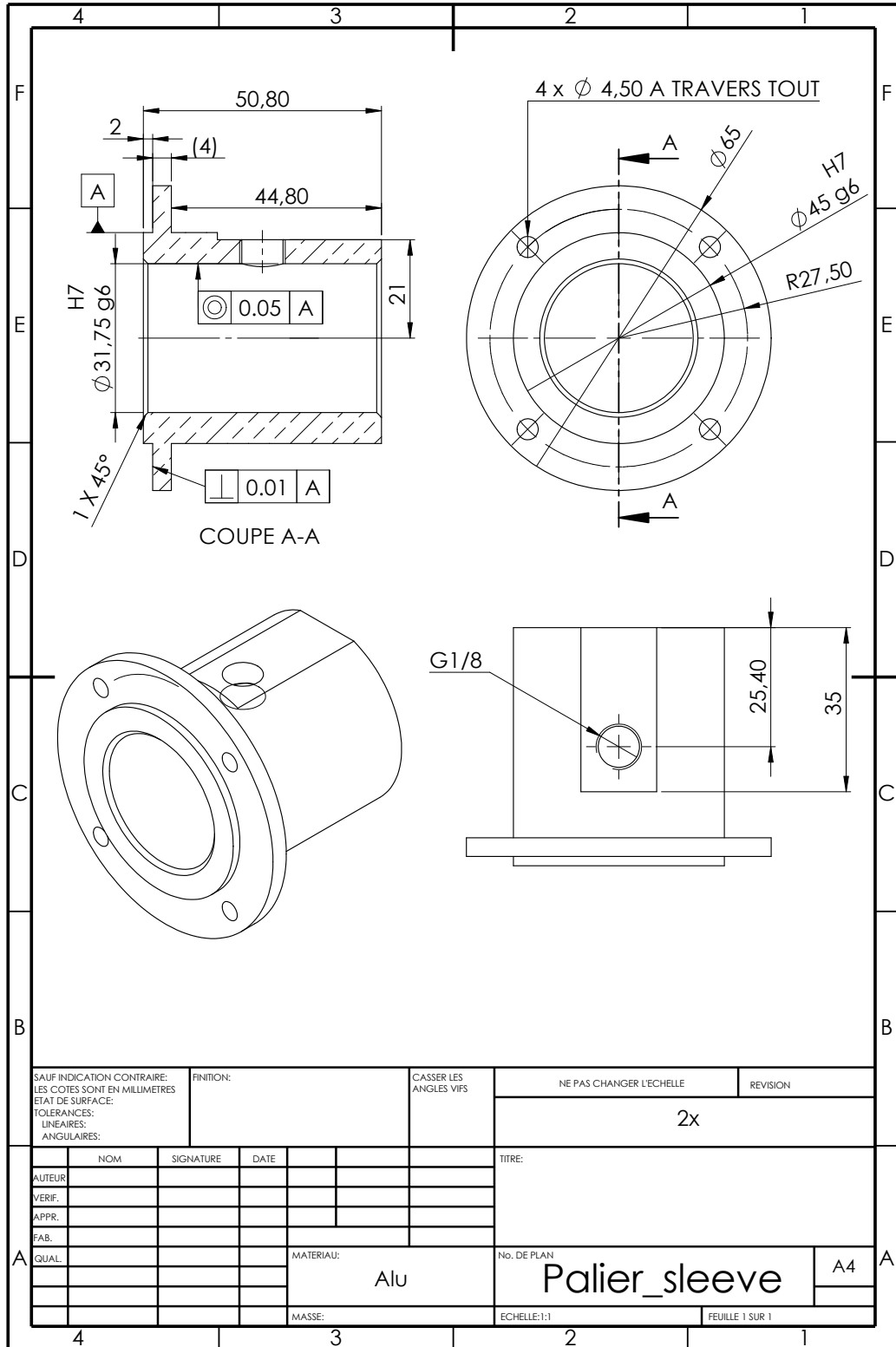

# L.7 Tube

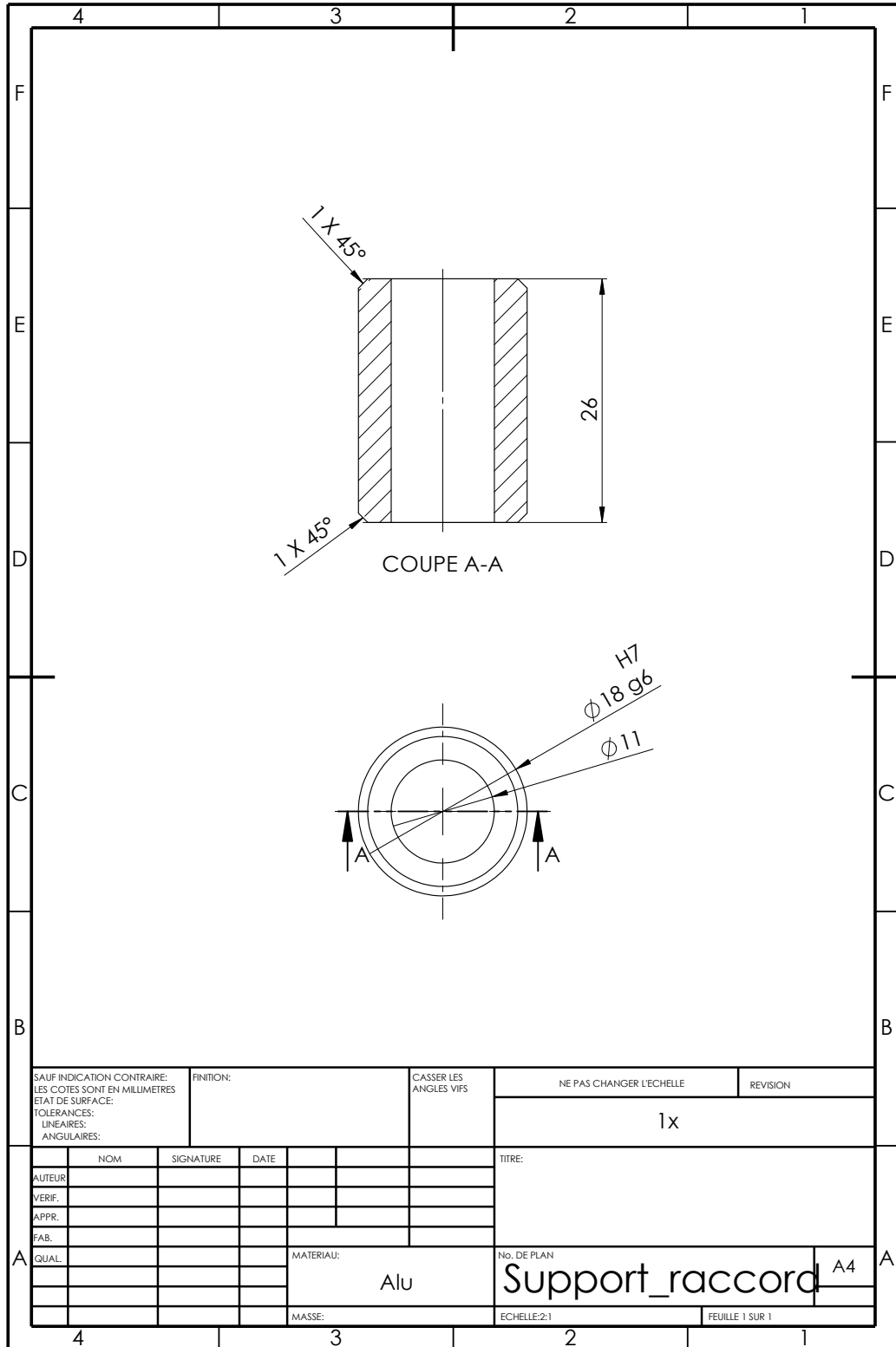

# L.8 Mounting bracket

