

Louvain School of Management  
and NHH – Norwegian School of Economics

# The Global Grid

Cost-Benefit Analysis: a wind farm in Greenland  
linked to Europe and North America

Research Master's Thesis submitted by  
Martin Charlier

With a view of getting the degrees:  
Master of Science in Economics and Business Administration, major in  
Energy, Natural Resources and Environment  
Master in Business Engineering, major in Corporate Sustainable  
Development

Supervisor :  
Karl Rolf Pedersen

Academic Year 2019-2020



# Acknowledgements

This thesis would have been really different without the support I received from my entourage.

I would like to thank my supervisor, Professor Karl Pedersen. He showed me a keen interest in the thesis topic and offered me a good angle to tackle the subject.

Also, I would like to thank the professors I have met this year at NHH. They reinforced my passion about energy and environment related topics and challenged me all year long.

Thank you Sébastien Herman, my friend, for helping me reviewing my thesis and granting me your precious time.

Eventually, I would like to say thank you to all my relatives, my kitchenmates, my parents, my sister and friends for supporting me in my decisions and my projects.

Norwegian School of Economics

Bergen, June 2020

---

Martin Charlier

# Abstract

For a long time now, energy has been a subject worthy of interest to me. I developed a keen interest along my childhood about energy and how we use it. Later, in my bachelor program, some classes woke up my deepest interests about energy. Nowadays it is even making steadily more sense to focus on that topic given the current environmental issues.

The path I decided to follow at NHH is environment related. Indeed, I chose the Energy, Natural Resources and Environment major. The classes I picked provided me a global vision of the current situation and its stemming challenges. Presently, I feel I have the right tools to understand global environmental issues.

In addition to that, I truly think it falls within our generation's abilities to come up with innovative and future-oriented solutions to cope with climate global issues.

Those are the reasons why I chose to write my thesis about an energy/environment-related topic.

**Keywords** – Global Grid, Cost-Benefit Analysis, Interconnectors, HVDC lines, Transmission lines, Greenland, wind farm, Europe, North America, Global Energy Interconnection, Renewable Energy, Electrification, Decarbonisation

# Contents

<b>1</b>	<b>Introduction</b>	<b>1</b>
<b>2</b>	<b>Project Description</b>	<b>4</b>
2.1	Transmission system . . . . .	5
2.1.1	Voltage . . . . .	6
2.1.2	Transmission cables . . . . .	6
2.1.3	Converters & Interoperability . . . . .	7
<b>3</b>	<b>Global Power Market</b>	<b>10</b>
3.1	New managing institutions . . . . .	10
3.2	Global Market: way of operating . . . . .	11
<b>4</b>	<b>Opportunities</b>	<b>14</b>
4.1	Smoothing renewable energy supply and electricity demand . . . . .	14
4.2	Intercontinental trade . . . . .	15
4.3	Lower the needed power reserves . . . . .	15
4.4	Storage issue: no storage, no issue . . . . .	16
4.5	Decrease volatility of electricity price . . . . .	18
4.6	Superposition . . . . .	19
4.7	Improve the power security . . . . .	19
4.8	Countries with low RES . . . . .	19
4.9	Developing RES power plants in remote locations . . . . .	19
4.10	Developing RES power plants in developing countries . . . . .	20
4.11	Decreased dependency . . . . .	21
4.12	Low risk of embargo . . . . .	21
4.13	Bypass local AC grids . . . . .	21
4.14	Others . . . . .	21
<b>5</b>	<b>Drawbacks and Challenges</b>	<b>23</b>
5.1	Disturbances . . . . .	23
5.2	Attacks . . . . .	23
5.3	Dependency . . . . .	23
5.4	Very rich locations . . . . .	23
5.5	Opportunities attenuation . . . . .	24
5.6	Non-systematic improvement . . . . .	24
5.7	Oil and Gas advantages . . . . .	24
5.8	Job destruction and job creation . . . . .	24
5.9	Dissuasive capital investment . . . . .	25
<b>6</b>	<b>Investment Mechanisms</b>	<b>26</b>
<b>7</b>	<b>Cost-Benefit Analysis</b>	<b>28</b>
7.1	Project description . . . . .	28
7.1.1	Greenland . . . . .	28
7.1.2	Pathway & Cables . . . . .	30
7.1.3	Windmills . . . . .	32

---

7.2	Costs . . . . .	36
7.2.1	Station costs . . . . .	36
7.2.2	Line costs . . . . .	37
7.2.3	Integration costs . . . . .	39
7.2.4	Capitalised costs of converter station and DC line losses during the life of the project . . . . .	39
7.2.5	Operation & Maintenance costs . . . . .	40
7.2.6	Land acquisition and right of way . . . . .	41
7.2.7	Wind farm in Greenland . . . . .	41
7.3	Benefits . . . . .	44
7.3.1	Electricity production from the wind farm . . . . .	44
7.3.2	Trading between Europe and North America . . . . .	44
7.3.3	Other benefits . . . . .	47
<b>8</b>	<b>Discussion</b>	<b>48</b>
<b>9</b>	<b>Conclusion</b>	<b>51</b>
	<b>References</b>	<b>53</b>
	<b>Appendix</b>	<b>55</b>
A1	Cable boats . . . . .	55
A2	ROVs (Remotely Operated Vehicles) . . . . .	55
A3	Offshore Windmill construction . . . . .	56
A4	High Wind Logistics' boats . . . . .	57

## List of Figures

1.1	Breakdown of world greenhouse-gas emissions in 2000 (MacKay 2009) . . .	1
2.1	Possible Global Grid representation (Chatzivasileiadis et al. 2013) . . . . .	5
2.2	MT-HVDC link based on VSC technology (Maruf et al. 2016) . . . . .	7
4.1	Load profile scenarios (Ardelean & Minnebo 2017) . . . . .	14
7.1	Elevation of Greenland in meters (da Silva Soares 2016) . . . . .	29
7.2	Katabatic Wind scheme (Radu et al. 2019) . . . . .	30
7.3	Average wind speed (m/s) at 100m above ground from 2008 to 2017 (Radu et al. 2019) . . . . .	30
7.4	The North America - Europe cable pathway (Purvins et al. 2018) . . . . .	31
7.5	Mean wind speed at 10m height - site suggestions . . . . .	33
7.6	Generated power . . . . .	35
7.7	Cable burying from hudsonproject.com . . . . .	38
7.8	AC and DC, overhead and submarine cables costs (Yu et al. 2019) . . . . .	39
7.9	HVAC and HVDC transmission lines width for the same voltage (Yu et al. 2019) . . . . .	41
7.10	Costs split for a typical wind farm. Retrieved from guidetoanoffshorewindfarm.com. Full names of the categories: Development and Project Management, Turbine Foundation, Foundation Installation, Decommissioning, Nacelle, Cables, Turbine Installation, Rotor, Offshore Substation, Other Installation, Tower, Other Balance of plant, Maintenance and service, Other Turbine, Offshore Cable Installation, Operations . . . . .	42
7.11	Power flow in the European cable in 2030 (flow direction towards NA) (Purvins et al. 2018) . . . . .	45
A1.1	Cable laying boats from the 4 main cable laying companies . . . . .	55
A2.1	Example of ROVs . . . . .	55
A3.1	Picture of the assembly of an offshore GE Haliade 150 6MW in the Merkur wind farm in North Sea . . . . .	56
A4.1	MV BOLDWIND . . . . .	57
A4.2	MV VESTVIND . . . . .	57

## List of Tables

2.1	Voltage levels . . . . .	6
4.1	HVDC efficiency for distances in thousand kilometers . . . . .	17
7.1	The North America - Europe cable pathway . . . . .	31
7.2	IEC Wind Classes . . . . .	34
7.3	GE Haliade 150 6MW Characteristics (Retrieved from ge.com/renewableenergy on 09/06/2020) . . . . .	34
7.4	Effects of the Europe-North America interconnection on social welfare (in M€) (Purvins et al. 2018) . . . . .	46

# 1 Introduction

As previously mentioned, it is important to focus on global environmental issues. It ought to be everyone's first priority because it threatens the durability of the life on Earth. Lately, one figure caught my attention: in 2000, 74% of the greenhouse-gas (GHG) emissions were caused by energy use (see Figure 1.1).

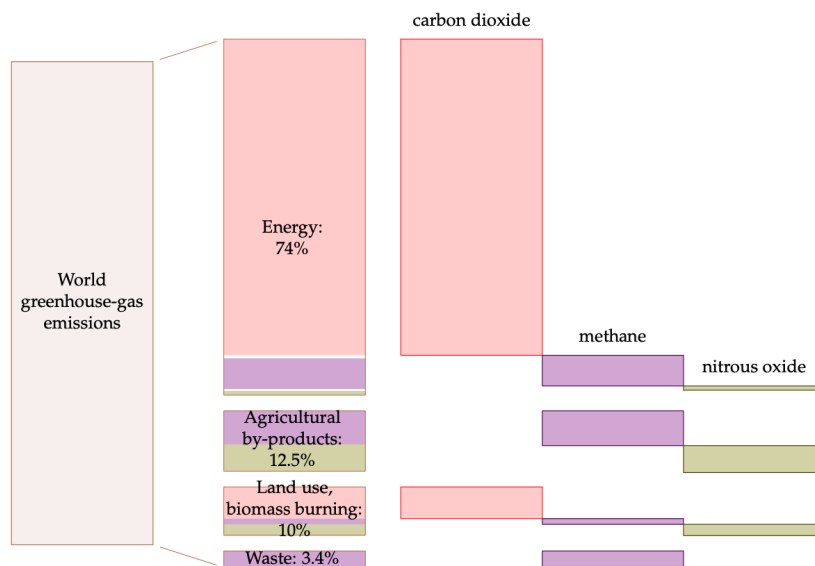

**Figure 1.1:** Breakdown of world greenhouse-gas emissions in 2000 (MacKay 2009)

Focusing on the energy industry and providing solutions to this industry will have the greatest impact in terms of GHG emissions reduction because electricity is emission free when we use it. It means that if we are able to produce energy without emitting particles, we will decarbonize the power industry and thus decarbonize the world efficiently (Brinkerink et al. 2019).

The demand for energy in the next years is expected to grow as the world population grows exponentially in developing countries. It has been forecast that energy consumption will grow until 2033 (DNVGL 2019). We should be careful with this statement: not only the population increase puts a stress on the environment, our patterns of consumption play a big role as well (Rosa & Dietz 2012). If we are not able to foster renewable energy sources, GHG emissions will keep growing. However, the DNV GL (2019) forecasts a decrease in energy demand after 2033 because our activities will require less energy, we will consume in a smarter way.

Fortunately, current trends push us to adopt renewable energy. This transition is known as the Energy Transition. Steadily more people are installing Photo-Voltaics (PVs) on their roofs, wind mills are built here and there, on-shore and off-shore, hydraulic dams are built to generate hydro power... That is true but renewable energy still does not count for enough in the global energy mix. In 2017, the modern renewable share in total final energy consumption only reached 10,9% while the renewable share had already reached 7,7% in 2000(IEA 2019b). Still in 2017, 19% of the energy mix is non-fossil. According to DNV GL, this share should reach 44% in 2050 (DNVGL 2019).

We can ask ourselves "What should we do to increase the renewable share in the global energy mix?". In the literature, we read that we should capture renewable energy in the areas where it is available in important quantities. We should get solar energy from arid areas where the sun shines most of the time and wind energy from places where the wind blows on a regular basis (in order to partially solve the irregularity issue of wind power generation and other RES (Renewable Energy Sources)(Chatzivasileiadis et al. 2013). The problem is that this energy has to be collected in very remote locations and we have to repatriate it to our shores. The two most realistic and promising solutions in my opinion would be:

1. To transform the produced renewable energy into hydrogen or compressed air in order to transport it by boats or trucks ;
2. To build a physical power grid to connect remote high potential locations to cities where the energy is needed.

This paper will focus on the second initiative. Its name is "The Global Grid" or "The Global Energy Interconnection". For our convenience, we will use the "Global Grid" designation in the thesis.

First, a detailed description of the Global Grid will be given in Chapter 2. We will describe the structure of the Global Grid : the technical features, where it will be located, what it will look like and how to implement it. We will analyse the functioning of this grid.

It is obvious, the Global Grid will need some institutions to operate this worldwide electricity market. Therefore, we will find which institutions are needed and what their roles will be. Different options are conceivable and we will analyse each of them. The

Chapter 3 will give a brief description about how the market will be structured, how the market participants will place bids and how the market will be cleared.

In the fourth Chapter, we will come up to the opportunities of the Global Grid. We will realise that the Global Grid offers a range of promising benefits to increase efficiently the share of RES and decarbonize the economy.

After the opportunities, it should be made clear that the project also comes with drawbacks and future challenges. The latter will be discussed in this fifth chapter.

The Chapter 6 will discuss the different investment mechanisms. Such a project will cost billions of euros. So, the way it will be financed has to be clearly discussed.

The Cost-Benefit Analysis will be presented in Chapter 7. All the costs and benefits related to each part of the project will be covered and analysed.

The Chapter 8 will discuss the results and Chapter 9 will conclude the thesis.

This kind of initiative (high power lines to transport energy) is not recent. It tends to be put in place in many areas over the world to interconnect close countries but nothing has been undertaken on a global scale. Given, all the great advantages this project promises, we could wonder why we do not hear that much about it. The thesis will present you the Global Grid and a Cost-Benefit Analysis of an interconnection between Europe and North America. The results will help us to understand the motivations behind this project.

## 2 Project Description

The first thoughts about interconnecting electricity grids around the world dates back to the first half of the 20<sup>th</sup> century. Buckminster Fuller was the first scientist to think about the potential benefits of merging electricity grids. The concept was first presented in 1969 at the World Game Seminar, where the UN agreed with the presented benefits (Brinkerink et al. 2019).

Since then, numerous studies regarding the increase of energy supply from RES in the global energy mix have suggested that transmission systems should be reinforced if we want that increase to be efficient and to reliably satisfy the energy demand around the world. This reinforcement could come from the interconnection of already existing grids and the harvesting of RES.

As a matter of fact, a lot of networks are already spanning the world. Some of them have actually been doing it for decades like: submarine communication cables, telecommunications and, the internet for example. Moreover, a huge number of commodities is traded at a global scale. Intercontinental trade dates back to Before Christ Era with the silk road for example. Nowadays, we trade oil, gas, gold and other metal and agricultural raw materials globally. It looks like electricity is the only "big" thing which cannot be traded between continents. It seems that a global power grid (The Global Grid) would be the next logical step (Chatzivasileiadis et al. 2013).

The Global Grid is the idea of creating a global electrical power grid spanning the globe. Doing so, we would interconnect continents and be able to exchange electricity through the world. The Global Grid would also harvest remote RES and connect the new biggest power plants around the Earth thanks to high capacity long transmission lines.

The core idea of this project is to foster the renewable energy production and make its use more efficient. The aim is clearly to provide a structure in which renewable energy can be used at the maximum of its capacity. There are some places where the wind blows substantially more often than anywhere else (some off-shore locations in the Indian Ocean or Greenland for example), creating high potential areas for building wind farms and some other places where the sun shines more often than average, also creating high

potential areas where we could install PV fields or use CPV technologies <sup>1</sup> (in arid areas for example). The Global Grid will be created in order to link those remote high potential locations with load centers where the energy is needed. On Figure 2.1, we can observe an eventual example of what a Global Grid could look like. This is nothing fixed but this schematic grid shows us a plausible way to interconnect continents and get renewable energy from high potential remote locations.

A lot of people and industries around the globe will benefit from the low production costs of renewable energy and most importantly, use renewable energy. This is essential because the access and the utilization of renewable energy is the cornerstone in the fight against Global Warming (IEA 2019a).

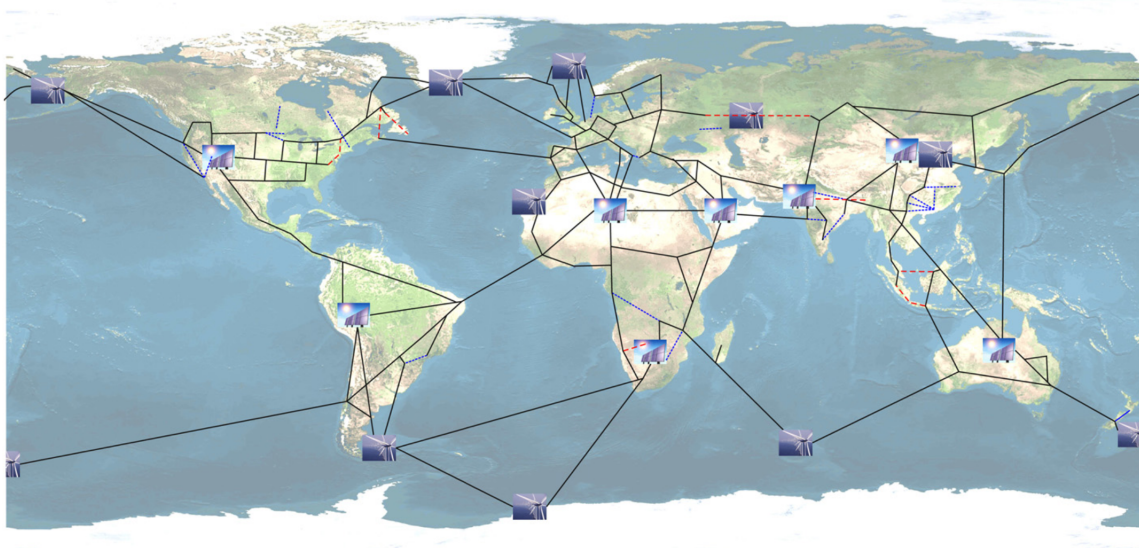

**Fig. 1.** Illustration of a possible Global Grid. The blue dotted lines indicate the HVDC lines with a length over 500 km, that are already in operation. The HVDC lines over 500 km currently in the building/planning phase are indicated in dashed red lines (the list with the illustrated HVDC lines is not exhaustive). The location of the RES power plants has been based on solar radiation maps, average wind speeds, and sea depths (see Appendix C). (For interpretation of the references to color in this figure legend, the reader is referred to the web version of this article.)

**Figure 2.1:** Possible Global Grid representation (Chatzivasileiadis et al. 2013)

## 2.1 Transmission system

From a more technological point of view, we could wonder what the Transmission System will be made of. When thinking about the grid design, many choices can be considered. Which type of cables should be used? Which voltage would be the most appropriate? Which converters should be built?

<sup>1</sup>CPV is a system that focuses solar radiation on solar cells thanks to curved mirrors and lenses.

### 2.1.1 Voltage

First, we will tackle the voltage choice. The real issue behind the voltage decision is the losses we encounter when transmitting electricity over long distances. Current technologies allow us to alleviate the losses issue. The use of higher voltage decreases the percentage of losses per kilometer. Current applications proved that Ultra High Voltage DC (UHVDC) lines (more or less 880kV) experienced around 3% of thermal losses every 1000km. In order to be perfectly clear about the different voltage intensity and their corresponding names, you can find the necessary information in Table 2.1:

Name	Voltage level	Use example
Low Voltage (LV)	from 70 to 600 V	Domestic use
Medium Voltage (MV)	from 0.6 kV to 33 kV	Rural power transmission lines and industrial power distribution
High Voltage (HV)	from 33kV to 220 kV	High voltage transmission lines and heavy transmission towers
Extra High Voltage (EHV)	from 220 kV to 760 kV	EHV transmission lines
Ultra High Voltage (UHV)	above 800 kV	UHV transmission lines

**Table 2.1:** Voltage levels

### 2.1.2 Transmission cables

Transmission lines can be of 3 kinds: AC, DC and gas-insulated lines. Most of the lines in the world are AC lines. It could thus seem logical to prefer AC to build the backbone of the Global Grid. The issue is that countries are asynchronous: every country uses AC at its own voltage. Thus, using AC lines would mean that every country would have to use the same voltage as the others. This is obviously unrealistic. Moreover, AC lines are unsuitable for under-sea lines exceeding 60km (undersea gas-insulated lines cannot exceed 100km). However, DC lines can conduct electricity undersea on very long distances (Chatzivasileiadis et al. 2013).

In addition to that, HVDC lines can be equipped with Voltage Source Converters at both ends of the line to convert the source (from DC to AC) and the voltage (from high voltage to a lower one) so the electricity conducted on the HVDC lines could be used on national AC transmission lines. HVDC lines are therefore suitable to interconnect asynchronous systems and conduct electricity undersea for long distances. Furthermore, thanks to VSC

combined with HVDC lines allow a rapid control of transmitted power (Navpreet et al. 2012).

### 2.1.3 Converters & Interoperability

VSC is the best converter that can be used with a view to building a Global Grid. Indeed, VSC enables Multi-Terminal HVDC (MT-HVDC). It means that these converters can be connected to several HVDC lines and thus become a node in the grid. For example, on Figure 2.2, the VSC technology allows to interconnect multiple off-shore generators with one on-shore grid through a MT-HVDC link.

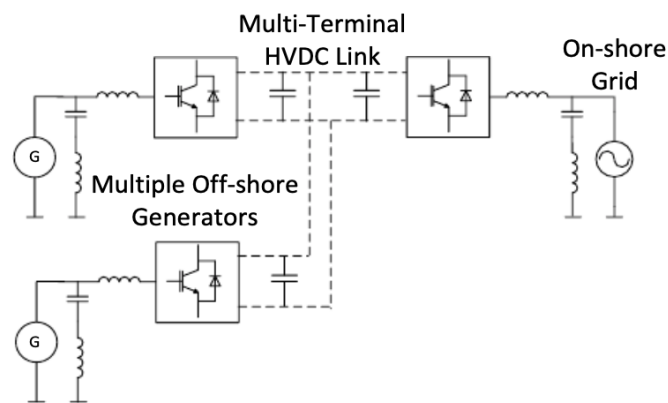

**Figure 2.2:** MT-HVDC link based on VSC technology (Maruf et al. 2016)

Unfortunately, this technology has been used with HVDC for a few years only. In 2017, only a few MT-VSC-HVDC had been built worldwide. The proliferation of MT-VSC-HVDC around the globe is slow. It is likely that these converters will be built one by one by different organisations/countries.

The building of MT-VSC-HVDC converters here and there around the globe and the fact that they are designed and operated differently will have damaging consequences. Indeed, if we have a long-term vision, these converters will one day be linked altogether. A lack of standardization about grid control now will lead to interoperability issues in the future. The interoperability is the ability for systems, units, materials (converters for example) to operate together, simultaneously with a good dynamic. Hence, we have to forecast the connecting role of these converters in a Global Grid context.

In order to solve this interoperability issue, we need some clear and standardized instructions so that converters would have the same control structure.

Many interconnections between countries have been built in Europe while some others have only been commissioned. BritNed is a 1GW 260 km long HVDC subsea transmission line built in 2011 between United Kingdom and the Netherlands. NordBalt is a 700MW 450 km long HVDC subsea transmission line built in 2016 between Sweden and Lithuania. NorNed is a 700MW 580 km long HVDC subsea transmission line built in 2008 between Norway and the Netherlands. The latter is said to be the longest subsea HVDC link. SA.PE.I is a 1GW 435 km subsea transmission lines built in 2011 between Sardinia and Italy mainland. As we see it, West-European countries begin to be interconnected. Many other projects with higher capacities and longer distances are projected to be built in the coming years such as NordLink between Norway and Germany (1.4GW, 1332km, subsea HVDC), NorthSeaLink between Norway and UK (1.4GW, 720km, subsea HVDC) (Brinkerink et al. 2019). As we notice it, Norway is involved in several grids interconnections projects. The reason behind this high involvement is that the country has the largest hydro power capacity in Europe. By being linked to other countries, Norway can import excess renewable energy produced in other countries while not using its hydro capacities. At the same time, it can also export to those interconnected countries when the latter face high energy peak demands (NorthSeaLink 2020).

With the ongoing growing number of interconnection projects, we can expect the whole Europe to be interconnected one day. Similar projects are seeing the light of the day on other continents. In the United States, the country is so big that the power grid has not been developed on a national level. It is divided in three separate grids working independently from each other, like islands. The "Tres Amigas" project aims at interconnecting the three parts of the power distribution network so they could sell and buy energy to each other (Reynolds 2012).

On the other side of the earth, Australia has a huge solar energy source potential in the South-West and central parts of the country. Some studies have been carried out to demonstrate the potential benefits of exporting Australian solar energy to South-East Asia countries (Andrew et al. 2012). But the most thriving part of the world in terms of HVDC transmission lines is China. Tens of HVDC lines have been built across the country to harvest the renewable energy. The HVDC lines go from central and Northern parts of the country to bring renewable electricity to the East where load centers are located (Qin et al. 2016).

---

If the trends keep going, a Global Grid would be the next logical step. Thus, the objective would be to link all the already existing HVDC lines to create a Global Grid. To do so, we need some standardization rules.

## 3 Global Power Market

### 3.1 New managing institutions

Interconnectors between already existing HVDC lines will lead to the establishment of a global market. Chatzivasileiadis and al. (2013) suggest the establishment of two regulating institutions: the global regulator and the GSO (Global System Operator) .

Within every country, electricity grids are managed by two types of institutions: TSOs (Transmission System Operators) and DSO (Distribution System Operators) . The TSOs are responsible for managing the high-tension and very high-tension lines. These lines are connected to power plants, big industries and to the DSO's facilities. Concerning DSOs, they are responsible for maintaining and improving their medium and low voltage lines which are linked to the small consumers and the TSOs facilities as aforementioned. Thus, their role is to dispatch electricity to small and medium enterprises and to households.

On a larger scale, electricity trades between neighbouring countries are managed by larger institutions. These ones take care of the cross border electricity trades and flows. In Europe, the ENTSO-E (European Network of Transmission System Operators for Electricity) fills the position. They also keep improving the system and they coordinate market activities. They represent 42 TSOs from 35 different countries. On top of that, ENTSO-E has a leading role to play in the European energy sector. Indeed, Europe is experiencing the Energy Transition. The European Green Deal is made of a set of policies aiming at making Europe climate neutral by 2050. The objective will be reached thanks to a high integration of offshore wind farms and HVDC interconnectors. The ENTSO-E's role is to comply with the policies and insure the interoperability between these connectors. Thus, they have a role to play in the European control structure standardization (ENTSO-E 2020).

In a view of establishing a Global Grid, we will need a wider system operator that we call the GSO. Its role will be the same as system operators. The other needed institution is the Global Regulator. The Global Regulator will act as a supervisor ensuring communication between the different parties as the ENTSO-E and insuring the security of electricity supply. The numerous interconnections can have unwanted effects on other grids and

propagate disturbances. This has to be studied carefully in order to avoid a global blackout, know how to prevent it from happening and how to react if it happens,... The Global Operator will also care for the good running of the market.

## 3.2 Global Market: way of operating

Two scenarios are conceivable: a horizontal one and a vertical one.

### *HORIZONTAL*

The first possibility is a horizontal scenario. In this operating scheme, every entity is playing a role on the global power market. It means that each entity will place bids for power supply and demand at the global level. AC and DC grids will be considered as a unified grid, a whole market place.

### *VERTICAL*

The market will be top-down managed. The DC Grid will be on top of AC local Grids. Each regional actor will act for its own sake. The GSO will clear the market on the DC Grid and regions will be assigned power quantities. After the DC management, the regions will manage their own AC Grids. Each region, knowing how much power they have to inject or absorb from the DC Grid and knowing the bids for power supply and demand, will assign power and financial exchange information to its actors and clear its own market.

The main advantage of a vertical operating scheme is that it implies no significant structural changes in local AC Grids.

The formation of a global market will not happen overnight. The concerned parties will join the aforementioned institutions when their region will be linked to the Global Grid. The interconnectors will be built step by step. Hence, the different parties will join step by step as well.

Both of these conceived scenarios might seem to be easy to understand. Nevertheless, they arise real challenges. The market could be oligopolistic and have an impact on prices; prices may be driven by the ability to generate renewable energy instead of the demand; the increasing share of RES in the energy mix can lower the electricity prices and cause non-profitability issues for fossil power plants ; ... Some financial drawbacks can be assessed but the project has a lot of opportunities to offer. Societal benefits can

counterbalance the financial drawbacks. This will be discussed in the following chapters.

Before moving to the next chapter, it is important to introduce two new concepts : **Intermittency** and **Dispatchability**. Both are very important characteristics of energy sources and play role in energy and electricity markets.

### *Intermittency*

The intermittency (for energy sources) refers to the fact that the energy source depends on external sources or factors of production. This is especially true for RES (Renewable Energy Sources). It means that the energy source cannot be directly controlled. There are times it will work and other times it won't because of external factors (explained herein-below).

Solar, wind, waves and small-scale hydro are examples of intermittent RES :

- Solar: seasons make solar energy sources intermittent. Clouds and day/night also causes intermittency of solar technologies;
- Wind: wind depends on solar radiation differences between two areas making high and low pressures and thus creating wind. Wind is not blowing all the time at every single place, sometimes it blows, sometimes it does not. Wind energy sources are thus intermittent;
- Waves: waves are caused by the attraction between the moon and the earth. The moon can be far from the earth and have a low impact or be really close and have a higher impact, creating higher waves. Moreover, the wind speed also has an impact on waves. Thus, waves do not have equal sizes all the time, creating intermittency of this RES;
- Small-scale hydro (only when using the flow, when there is no reservoir): the flow going through a small-scale hydro is dependent on ice melting, the rain intensity,... Thus, small-scale hydro is intermittent as well.

### *Dispatchability*

The dispatchability of an energy source is the ability to turn it on and off whenever we want on a very-short period of time (a few minutes at most). Thanks to dispatchable energy sources, the total supply on the market can be reactive and controlled to meet the demand. Among dispatchable RES, we can find large scale hydro and biomass. The reservoir outflows can be turned on and off at any time, thus producing energy or not, as we want. The other RES (solar, wind, wave and geothermal) are non-dispatchable.

The non-dispatchable sources depend on external factors or technological matters or even limits in production that makes the technology impossible to be turned on and off in a short time.

## 4 Opportunities

A Global Grid spanning the world would have a myriad of opportunities as well as some challenges and drawbacks which will be discussed in the next 2 chapters.

### 4.1 Smoothing renewable energy supply and electricity demand

Typical load curves have two peaks a day, one in the morning when people wake up and go to work and one in the evening when people get back from work. These peaks represent moments of high electricity consumption. As a result of time difference around the world, a global grid gathering all energy consumption would flatten the global load curves as countries have their peak demand periods one by one. Hence, the electricity demand would be smoothed thanks to the longitudinal market integration and time-zone diversification.

Ardelean and Minnebo (2017) showed some complementarity between Europe and China RES generation and energy demand. In Western China, a region with a large solar potential, the solar radiations bring a lot of energy from 9 A.M. to 5 P.M. while the consumption is at base load in this area. At the same time, the morning peak load is occurring in Europe and the evening consumption starts rising in Eastern China (Figure 4.1).

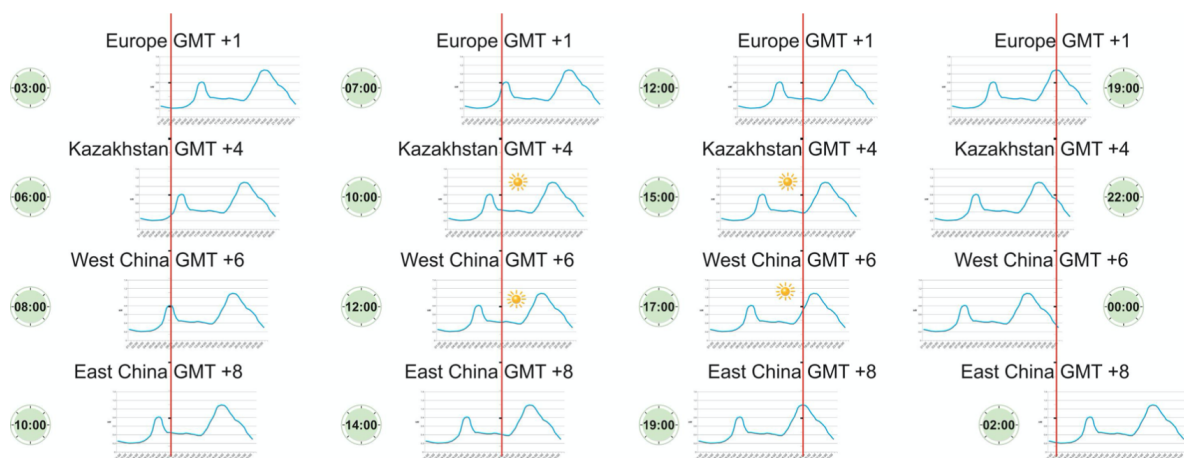

**Figure 4.1:** Load profile scenarios (Ardelean & Minnebo 2017)

Moreover, we can also use latitudinal integration to smooth supply and demand. The fact is that RES generation is impacted by seasons and seasons are inverted on both hemispheres. Bringing latitudinal integration will also bring seasonal diversity and contribute to a smoothed supply and demand. For example, the longest nighttime in 3 North American deserts is 14h. When we link these 3 deserts with 3 South American deserts, the length of the longest nighttime falls by 5h to 9h. It means that if the 3 North American deserts were not connected to the 3 South American deserts, no power from deserts would be generated for North America during 14h instead of 9h when North and South America are connected (Grossmann et al. 2014).

Further details about longitudinal and latitudinal integration will be given later.

Then, most of RES are non-dispatchable. Thus, the electricity production is not in tune with electricity demand: wind can blow a lot at night while energy demand is low or PVs can generate a lot around 1 P.M. on sunny days when electricity demand is at its lowest for example. Thanks to the Global Grid, this renewable energy excess (which could have been possibly lost) will be absorbed on the HVDC grid and be injected in areas where it is most needed.

## 4.2 Intercontinental trade

Excess renewable energy will be the subject of trade between countries, even between countries standing on different continents. Indeed, it has been shown that buying and importing renewable energy from the best RES power plants in Europe to US would be more profitable than buying electricity generated from expensive fossil power plants in the US.

## 4.3 Lower the needed power reserves

The most crucial elements in local grid management are the frequency and the voltage (respectively 50Hz and 230V in Belgium and in the Nordic market for example). Both should always be kept constant by system operators balancing load variations. The electricity supply has to perfectly match the demand at any time in order to keep these variables constant. Dispatchable energy sources are thus very important. The latter can

act as power reserves.

The growing RES integration comes with its well known intermittency and dispatchability issues. If we want to be able to rely on intermittent and non-dispatchable RES, we must have consequently growing dispatchable power reserves so the demand can perfectly meet the supply at any time.

However, the Global Grid can bring a solution to that. Indeed, system operators must withhold some capacity to balance load variations. These load variations are high during the day (high withheld capacity) and happen to a lesser degree during the night. Furthermore, due to the time difference, the high load variation periods happen at different moments, e.g. high power reserves needed in Europe during the day while low power reserves are needed in the US during the night. A line between the two continents can provide control of available power. Thereby, the Global Grid can decrease the power reserves within a region.

The Global Grid and its numerous interconnections can save some costs. Actually, the building of dispatchable power plants can be avoided. It has been shown that the need for power reserves can be cut by 2 to 8 times as a benefit from the Global Grid (Aboumahboub et al. 2010).

## 4.4 Storage issue: no storage, no issue

Excess power caused by very windy and/or sunny weather conditions needs to be stored, otherwise it becomes non-transmissible and it can cause congestion problems on the grids.

What are the best storage solutions available today? Currently, the four best storage options are : pump-hydro (use a pump to fill a dam so we can use the hydro power later), compressed air energy storage system, redox-flow batteries and hydrogen storage.

**Pump-hydro and compressed air energy storage systems** are the two storage options with the most future potential. However, all pump-hydro sites located near load centers have been used and compressed air energy storage systems have a low efficiency (50 to 70% only). Furthermore, only few sites would be appropriate. The use of hydrogen is still controversial but has a thriving future in the lorry, bus and boat sectors.

The Global Grid bypasses the storage issue. The grid would absorb the excess electricity

km (Thousands)	Efficiency
1	97%
2	94%
3	91%
4	89%
5	86%
6	83%
7	81%
8	78%
9	76%
10	74%
11	72%
12	69%

**Table 4.1:** HVDC efficiency for distances in thousand kilometers

and supply it in regions where it is needed. HVDC (+/- 800kV) has an excellent efficiency. The losses are approximately 3% every 1000 km. The EASE (European Association for the Storage of Energy) claims that actual pump-hydro storage systems reach from 70 to 85% of efficiency.

In Table 4.1, we computed the efficiency of HVDC lines for distances up to 12 000 km. As we can see, HVDC lines stand within the same efficiency range as pump-hydro from 5 to 12 thousand kilometers. Shorter distances are even more efficient. A line between Europe and North America would not exceed 5 thousand kilometers, making HVDC lines more efficient than pump-hydro storage. This being said, it is important to mention that bulk storage systems are usually seen as substitutes for HVDC submarine lines. In fact, bulk storage systems are cheaper. However, submarine HVDC lines have noteworthy advantages.

First, the HVDC lines can absorb electricity and supply it at any time, 24h a day, 8760h a year. The technology does not need to be charged once it has delivered all its electricity.

Second, both ends of the HVDC line will make profits thanks to the available cheap renewable energy.

Third, grids need to be reinforced anyway. If we could store all the excess electricity produced, we would still need the grid to be reinforced by a factor of 65%.

Fourth, the Global Grid will span the world, bringing electricity in remote places. Some remote places have a very large RES potential. Bringing electricity in these places will

help them to build RES power plants. For example, Greenland has a large hydro potential which exceeds the "country"'s needs<sup>2</sup>. Alaska, Siberia and Africa are also large potential areas.

## 4.5 Decrease volatility of electricity price

The RES are intermittent and the high penetration of RES on the market has a substantial impact on electricity prices. When there is no wind and low solar radiation, prices rocket. On the other hand, when we experience windy and sunny conditions, electricity prices might plummet and even be negative on the SPOT market.

The Global Grid will bring a solution to that. The excess RES power will be absorbed by the grid and supplied in areas with low RES power generation, offering thus low-cost electricity to places which need it. It can be argued that in general, people will benefit from relatively constant and lower prices. The wind is always blowing somewhere and the sun is always shining somewhere too. As a matter of fact, the world spins on itself and around the sun such that day and night happen at the same time at different places on earth. So, we have that longitudinal characteristics about the sun shining during the day and then not benefiting from it at night. On top of that, due to the tilt of the Earth, we have this latitudinal seasonality. It causes the seasons to be opposite on both hemispheres. So the sun intensity is also different on each hemisphere depending on the time of the year.

The sun is also the source of wind because of the air pressure differences it creates. Searchers have found some places where the wind blows more often than on any other part of the globe, they have also carried complementarity analysis of wind regimes between several regions.

This illustrates perfectly the fact that excess generated electricity by RES at one place could always find a final user at another place where RES does not perform that well at that very moment. Customers will thus benefit from lower prices on average.

---

<sup>2</sup>Greenland has a hydro potential of 800.000GWh/year while its energy consumption is only 300GWh/year

## 4.6 Superposition

The Global Grid can be built on top of the already existing AC grids. It would be a grid to link power plants wherever they are located with load centers and remote locations.

## 4.7 Improve the power security

First, the Global Grid, if correctly designed, will have low congestion and therefore low congestion costs). This could be achieved in two steps :

1. Having multiple points of absorption/injection within a single area so that flows can be managed more easily and congestion can be avoided;
2. The AC grid must be reinforced so that it can transport high power flows from & to the HVDC lines to avoid congestion.

Second, the more interconnections there are, the safer the system security will be. If one line is defective, other close lines will be able to support the flow and supply the area anyway.

Third, the VSC technology is really revolutionary. It is able to control independently active and reactive power and so, have a better control of the lines voltage. In fact, when the voltage is lower or higher than usual, machines can speed up or slow down and become asynchronous. Thanks to the VSC ability to control independently active and reactive power, and so, controlling the voltage on the lines, these desynchronisations are less likely to happen.

## 4.8 Countries with low RES

The countries with low RES potential could benefit from the Global Grid to import green energy and increase the share of RES in their final energy consumption.

## 4.9 Developing RES power plants in remote locations

Some places have a big RES potential but it is very difficult to build a power plant there because there is no available power at this place. For example, remote areas such as an

island with a huge wind potential or the middle of an arid place or even a place in the middle of the mountains with a large hydro power potential. The Global Grid will span the world and thus bring electricity closer to these places. As aforementioned, Greenland has a huge hydro power potential but not enough power is generated on this sparsely populated island to build hydro power plants without importing enormous quantities of power.

The sparsely populated areas are very convenient to build RES power plants. Also, in a view of decarbonating the economy, sparsely populated areas could be ideal to install nuclear power plants. However, this idea remains sensitive as people stay reluctant about nuclear. Many energy experts claim that the decarbonisation of the economy will need the help of the nuclear.

Getting back to business, we have to realise that highly developed areas will not be able to meet our need of substantial RES capacity development. The biggest RES power plants will be built at remote locations and be linked to major load centers. Along the interconnections, the local AC grids will be given the opportunity to be connected to HVDC lines. Thus, they will make an optimal use of their local resources as they will be able to inject excess power on the HVDC line and absorb what they need to meet their local needs.

## **4.10 Developing RES power plants in developing countries**

We can find similar challenges in African countries. For them, having an access to the Global Grid could be an opportunity to develop themselves and develop their own RES power plants thereby contributing to the world decarbonisation and electrification.

Also, some African countries have not had their own industrialisation and their economic development yet. In addition, the African population is about to soar in the coming years. As a result, the African energy needs will skyrocket. To meet the demand, African countries will have to come up with solutions. Building new power plants, supporting operation and maintenance costs, capital expenditures and fuel costs is way more expensive than investing in grid infrastructure. Indeed, Europe can relieve North-African growing

demand. Over a second phase, Africa could also be connected to other continents. This is applicable to every growing economy surrounded by other countries disposing of high generation capacities available.

## 4.11 Decreased dependency

The numerous pathways will have for consequence that the energy imported in a country may have a very high number of suppliers. The more suppliers, the stronger the competition. As a result of competition and abundance of RES, the strong energy dependency of some countries will be decreased as they would benefit from a wide range of suppliers.

## 4.12 Low risk of embargo

Some resources held by a few countries only make an embargo easier to organise. The Global Grid and the numerous resulting suppliers make embargo very difficult to organise. In fact, an embargo would be conceivable only if a very large number of exporting countries associate themselves. Hence, the vulnerability of the supply is really low.

## 4.13 Bypass local AC grids

Currently, generation from power plants are supported by the AC local infrastructure. High potential RES areas can be directly connected to HVDC lines, bypassing the local AC infrastructure and relieve it. It has to be mentioned that in the future reinforcement of local grids will be necessary to carry all power flows.

## 4.14 Others

- Exporting biomass from Russia to Europe is less efficient than using it to produce electricity in Russia and then supplying it through HVDC lines to Europe.
- A global interconnected world could help to meet policy targets.
- Countries can improve their image, moving from a petrol exporter to a green electricity supplier.
- Green and sustainable jobs can be created.

- Environmental benefits from decreasing fossil power generation.

## 5 Drawbacks and Challenges

The Global Grid also comes with its own risks and challenges. The plans have to be studied carefully because they could be subject to global blackouts if not designed thoughtfully.

### 5.1 Disturbances

As it has been aforementioned, the ideal would be to have a multitude of lines in order to enhance power security. Nevertheless, the high number of lines could be the cause of disturbances. The new couplings will propagate these disturbances and a global black out could be at risk.

### 5.2 Attacks

Brinkerink et al. (2019) highlight that the grid could be subject to attacks from terrorists. This trail seems baseless. However, if one line becomes unusable, other surrounding lines can transfer the energy as well and make the attack inconsequential on a transfer aspect.

### 5.3 Dependency

Some countries already consider themselves as energy dependent on energy exporting countries such as Russia for gas and OPEC for oil. Some of them will one more time be dependent on (renewable) energy from countries with large RES potential.

### 5.4 Very rich locations

In the past, we have seen that regions with a lot of wealth which were poorly managed have been victims of conflicts for long years (in Kivu, Congo for example). We have learnt that valuable resources have to be carefully managed. However, in this situation, the product would be electricity and electricity cannot be stored (efficiently). So, conflicts are less likely to happen.

## 5.5 Opportunities attenuation

The Global Grid offer the opportunity to smooth supply and demand on a global level. However, this opportunity is attenuated by smart grids. Smart grids are flourishing solutions aiming at locally smooth demand and supply. The best-known is of course the microgrid. This smart grid solution is the exact opposite of the Global Grid, trying to make neighbourhoods or small groups of companies being self-sufficient and energy independent from the rest of the grid.

## 5.6 Non-systematic improvement

The Global Grid will foster the RES, that is honourable. However, we have to keep in mind that emissions come from the burning of fossil fuels. The objective behind current Climate Agreement is not to foster RES, it is to decrease emissions. Fostering RES is only a means to an end. Nevertheless, the goal will be reached on the proviso that the fostered RES replace fossil fuels. Consuming less fossil fuels will be the sine qua non condition to reduce emissions.

## 5.7 Oil and Gas advantages

Oil and Gas have benefits that the Global Grid cannot compete with : oil and gas can be transported wherever we want, whenever we want while the Global Grid will only be able to transport energy via the existing infrastructure. Moreover, Oil and Gas can be stored and used later with a 100% efficiency while electricity has to be consumed at the time it is produced and the market has to be balanced at any time.

## 5.8 Job destruction and job creation

If a country becomes an energy importer instead of an electricity producer, the country loses its economic advantages as job creation and economic activity. On the other side, some countries with large RES potential will benefit from job creation to build and maintain RES power plants.

## 5.9 Dissuasive capital investment

The high investment costs and risks constitute a true challenge for such ambitious projects. This element is the main argument against the Global Grid. Having a look at the already planned and built lines, we observe that land based HVDC lines range from 0.35 to 2 billion \$/1000km. Subsea lines are more expensive and range from 0.675 to 8 billion \$/1000km. Although these prices are really high, we observe a trend in the price decrease of these technologies. Technological development make HVDC long transmission lines always more affordable.

Building intercontinental transmission lines seems profitable anyway. In Asia, the increasing energy needs pushes governments to build long transmission lines between countries and within countries as well.

## 6 Investment Mechanisms

Two possible investment structures are common for financing submarine cables:

1. Regulated investment ;
2. Merchant transmission investment.

A third possibility is a mix of the two possibilities. De facto, a part of the capacity would be subject to regulation and the rest would be available for generating profit from trade. The "mix option" is probably the most realistic option, it has already been used in several submarine cable projects (between Sweden and Lithuania for example). Sometimes, banks also invest in wind farms (for example, a group of banks invested in the Merkur wind farm located in the German North Sea). Investing in interconnection could also be interesting for them.

Two conditions must be fulfilled for investment to happen:

1. The investors must have the willingness to invest in electricity grid projects (investors could be attracted by more profitable investments) ;
2. There must be enough power delivered from renewable sources. Otherwise, the project could lose some of its social benefits.

For such kind of projects, amortization periods are expected to be very long. Between 15 and 30 years to be precise. This long period makes submarine cable investments not attractive for private investors. Usually, countries themselves invest in such projects and decide how they will split the costs and the benefits. Then, it should be stressed that the few benefits compared to the costs per delivered MWh might not be attractive for private investors (Chatzivasileiadis et al. 2013).

The first-aim of the project is of course not profitability. Indeed, the aim is to increase the social welfare. The pursued goal is to have an amortization period shorter than the lifetime of the project, then it will bring social benefits.

The price differences between Europe and North-America (resulting from the time differences and thus the mismatches of the peak demand periods) will create some room for energy transfer between the two areas on the SPOT market. The difference between peak

and off-peak prices is generally around 30€/MWh and it can even exceed 100€/MWh. The longer the time horizon of the market will be (SPOT market < intra-day market < day-ahead market < long-term market), the narrower and smaller the price differences will be. For example, the peak - off-peak price difference on the day-ahead market can be around 20 and 50€/MWh. Profits can thus be generated by taking advantage of the time zone differences (Chatzivasileiadis et al. 2013).

It can be argued that the always increasing share of RES will decrease the price of electricity and we can assume that is correct in general. However, the volatility of RES can also lead to high volatility on day-ahead, intra-day and SPOT markets, leaving room for profits.

## 7 Cost-Benefit Analysis

### 7.1 Project description

Before going through the Cost-Benefit Analysis, we will have a deeper look at the specific features of this project. The four main elements worth considering are a site analysis (Greenland), a pathway analysis (sea bottom), a cable technology review and a windmill technology review. After considering these elements, we will be in position to realise a Cost-Benefit Analysis.

#### 7.1.1 Greenland

Greenland is a gigantic island located between Canada, Iceland and the Arctic. The island belongs to the Danish Kingdom. However, the island is autonomous and has its own legislature. Kalaallit Nunaat (Greenland in Greenland language) has a very low population density. Indeed, less than 60 000 people live on the 2 200 000km<sup>2</sup> of the island. Most of the island (more than 80%) is covered by permanent glaciers (410 449km<sup>2</sup> are not covered by permanent glaciers). The non-permanent iced areas are located along the coasts. The Southern cap is at the same latitude than Oslo while the most Northern part of the isle is only 700km far from the North Pole. Along the coasts, the temperatures usually vary between -15°C and 15°C.

Greenland is very rich in terms of renewable energy resources. The island has a very large hydro potential. Indeed, the hydro potential is estimated to be around 800 000 GWh/year (Chatzivasileiadis et al. 2013). In order to give a rough estimate, it is important to know that the Greenland annual energy consumption averages 2750 GWh (of which only 300 GWh was electricity consumption in 2010). The main issue with hydro is that the potential locations are really remote and very difficult to access. We have to keep in mind that the road infrastructure in Greenland is not well developed in sparsely populated areas and sometimes nonexistent in inhabited areas. All the "big" populated cities are located on the coast (most of them on the West coast). Some roads exists along the coast but the road infrastructure remains very low, most of the routes being made of gravels. When we consider a project in Greenland, the building of a road to reach the project

location usually has to be forecast.

In addition to the very optimistic hydro potential, Greenland also has an appropriate climate for installing wind farms. In fact, the Greenland topography is very interesting. Its shape looks like a cone with a decentered vertex. The top of the cone is located in the center-East of the Island, culminating at 3733 meters high. The shape of the island and the arctic climate provoke a well known phenomenon known as katabatic winds.

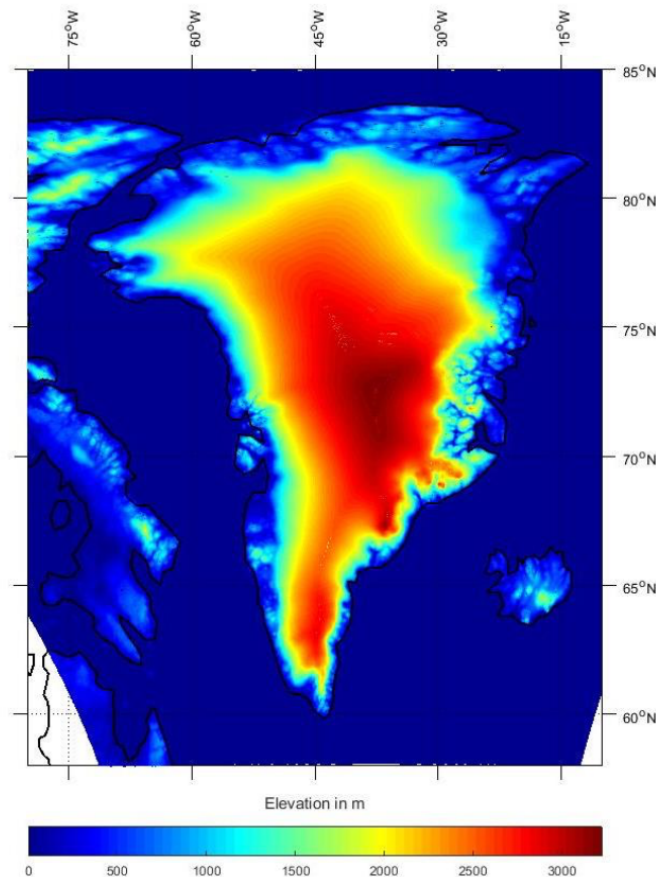

**Figure 7.1:** Elevation of Greenland in meters (da Silva Soares 2016)

Katabatic winds are caused by the topography of an area and its climate. In Greenland, almost the whole island surface area is covered by ice. This ice in contact with ambient air makes the latter colder. The colder air becomes more dense and the air is forced down the hill towards the ocean. This wind is driven by gravity, temperature gradient and inclination of the slope of the ice sheet. This wind is almost never-ending. Moreover, this phenomenon is increased when a low pressure area approaches the coast. Katabatic winds happen everyday regardless of the season (Radu et al. 2019). The best area to build a wind farm relying on katabatic winds is the south-eastern coast. It is at that place that

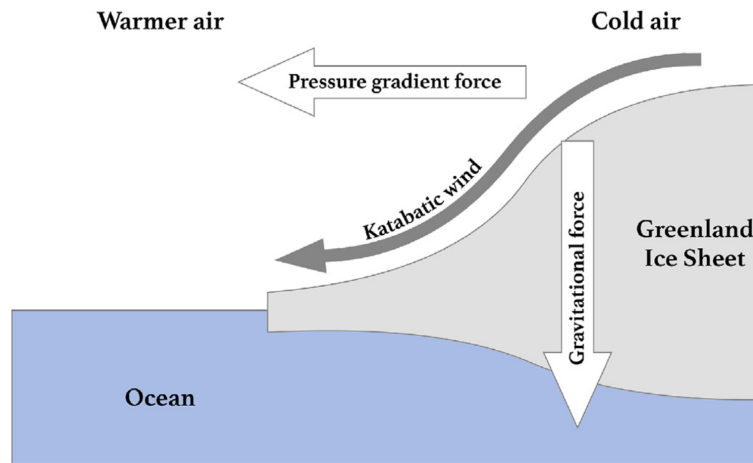

**Figure 7.2:** Katabatic Wind scheme (Radu et al. 2019)

katabatic winds are the highest as a result of steep slopes.

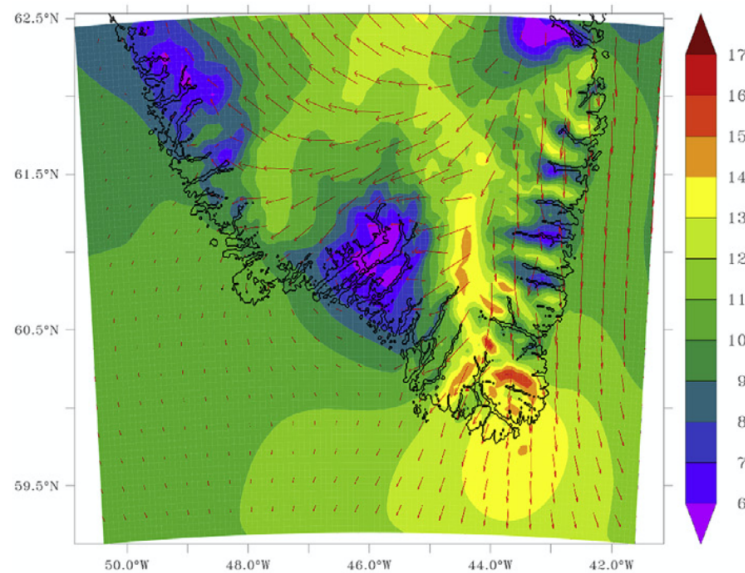
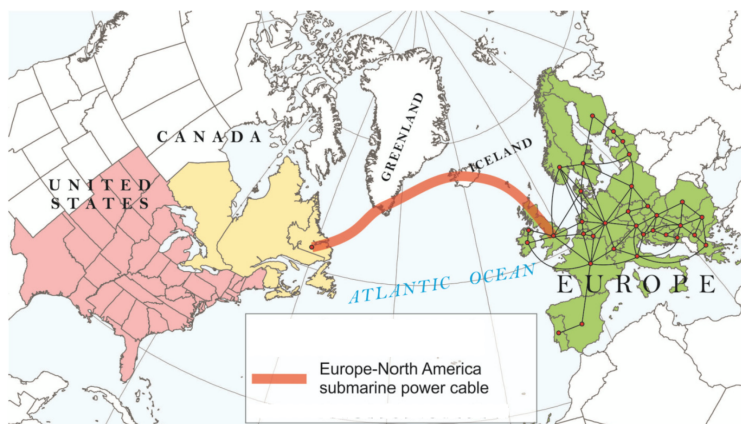

**Figure 7.3:** Average wind speed (m/s) at 100m above ground from 2008 to 2017 (Radu et al. 2019)

### 7.1.2 Pathway & Cables

The pathway we will analyze will span the Atlantic Ocean from the North of United Kingdom to the East coast of Canada, passing by the Faroe Islands, Iceland and the South coast of Greenland (Figure 7.4).

The Table 7.1 shows us the different segments lengths and depths. The total length of the cable will be 5850km and the maximum depth at which the cable will be laid down will be around 1200 meters. This is a very challenging project. In fact, we have already



**Figure 7.4:** The North America - Europe cable pathway (Purvins et al. 2018)

Segments		Length (km)	Max depth (m)
FROM	TO		
Scotland	East Iceland	900	1200
Through Iceland		650	OHL
West Iceland	East Greenland	600	800
East Greenland	South Greenland	700	OHL
South Greenland	Nuuk	700	OHL
Nuuk	Nearest Canadian shore	800	1000
Nearest Canadian shore	Quebec	1500	OHL

**Table 7.1:** The North America - Europe cable pathway

built deeper submarine segments (the deepest being SA.PE.I. with a 1650m depth in 2012). The longest HVDC submarine cable is NorNED with 580km built in 2007 between Norway and The Netherlands. The longest OHL is located in Brazil and is 2375 km long. The only 2 segments going beyond these limits is the segment from Nuuk to the nearest Canadian shore (800km) and the one from Scotland to Iceland (900km). Apart from that, the project is feasible on a technological point of view.

When we lay submarine cables, we need vessels equipped to welcome very long cable reels. Submarine cables should be made of the less possible segments. The more segments and junctions there are, the greater the risk of defaults. The vessels (Skagerrak and Giulio Verne) from the two biggest cable companies (Prysmian and Nexans) have a capacity of 7000 tons of cable each (see Appendix A1). Knowing that submarine cables weights between 30 and 80kg per meter, these vessels are able to carry between 90 and 250km of cables at once. Some lighter materials can be used when laying very long submarine cables such that boats can carry longer cables and reduce the number of junctions.

However, some very performing junctions have been conceived and make cable segments very reliable.

When the cable is laid, it has to be buried if the depth is smaller than 600m. Otherwise, the cable is just laid down at the bottom of the ocean (except in case of strong sea currents).

It is forbidden for boats to anchor and to fish near the submarine cables. Some accidents happen but hopefully, most of the time, they happen near the shores which makes the fixing easier.

The submarine cables we will use in this project has the following characteristics: a 3000 MW capacity and a 800 kV voltage.

### 7.1.3 Windmills

As it was mentionned above, the soil is not easily practicable in Greenland. The location of the windmills has to be chosen carefully. Some places show high mean wind speeds but also gusts which can be so violent that they could damage windmills. Some other places need roads to be built if we want to install windmills there.

Greenland landscapes are often made of steep slopes. We have to be aware that trucks transporting blades and machines to build the windmills can only ride slopes up to 7%. Slopes up to 15% can be climbed as well but only with the assistance of big machines to pull and push the trucks. The ideal locations are located along the shores. First, because the shores are easily accessible by boat. Second, they are not covered by permanent ice. Third, the shores benefit from the katabatic winds.

Figure 7.3 suggests that the Southern cap of Greenland would be the most appropriate location for a wind farm as the highest mean wind speed is observed at this location. However, further analysis about possible wind farm location and wind assessment have shown that the Southern cap showed a lack of homogeneity in wind speeds.

Windmills can only operate in a restricted range of wind speeds. Some are made to work when the wind is slow and some when the wind is fast. Too much heterogeneity among wind speeds at one place are thus a bad factor. Places near Nuuk (the capital city of Greenland, around 17,000 inhabitants) would be more suitable as the winds observed along the West coast are homogeneous, the access is the easiest but unfortunately winds are

rather slow. The best location is referenced as "Suggestion 6" on Figure 7.5. This location offers good perspectives for building a large wind farm as wind are quite homogeneous, blowing between 6 and 8 m/s. The range of mean speeds could seem pretty narrow but we have to keep in mind that the wind power is proportional to the wind speed cubed (Equation 7.1). When the wind speed doubles, the wind power is multiplied by eight.

$$P_{wind} = \frac{1}{2} \rho \pi r^2 v^3 \quad (7.1)$$

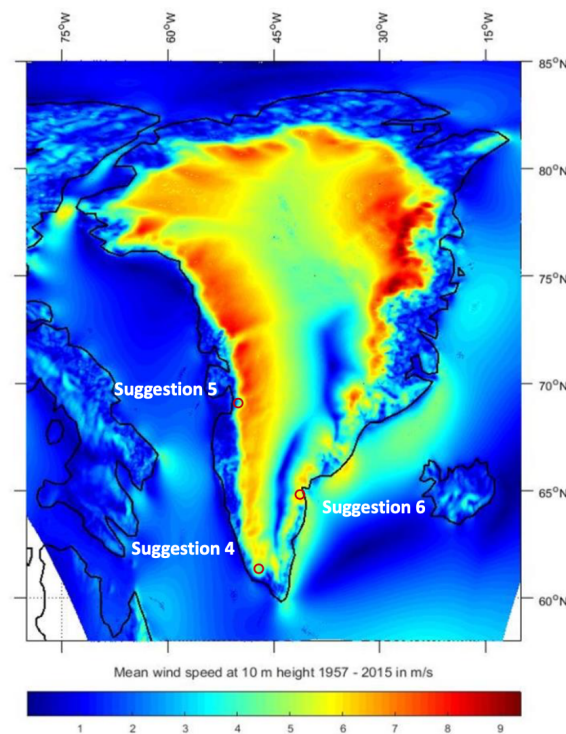

**Figure 7.5:** Mean wind speed at 10m height - site suggestions

Despite the arctic climate, windmills are able to work efficiently. Some technological progress allows windmills to operate in this cold regions. In fact, windmills for the North Atlantic region (Greenland thus) have only been in production for 15 years. Windmills manufacturer are now able to propose some models that meet the requirements of this kind of climate (high wind speeds, cold temperatures and rough wind conditions).

These wind turbines have power capacity varying from 500kW to 3MW. Jakobsen (2016) suggests that the best type of wind turbines for a Greenland wind farm is a 3MW power capacity, direct drive (DD) and doubly-fed induction generator DFIG turbine. The DD turbine has less critical components than regular turbines. DD-DFIG turbines are very

	Wind Class		
	1	2	3
Reference Wind Speed	50 m/s	42.5 m/s	7.5 m/s
Annual Average Wind Speed (max)	10 m/s	8.5 m/s	7.5 m/s
50-year Return Gust	70 m/s	59.5 m/s	52.5 m/s
1-year Return Gust	52.5 m/s	44.6 m/s	39.4 m/s

**Table 7.2:** IEC Wind Classes

robust but also very expensive compared to regular windmills.

The cold climate make some windmills specifications necessary : blade de-icing system, heated yaw bearing and lubrication system, heated gearbox and oil systems, heated main bearings and lubrication system, low temperature coolants and nacelle heating system. All these options are necessary to avoid expensive maintenance costs in the future.

A possible model of windmills is the GE Haliade 150, which is a 6MW power capacity windmill suitable for off-shore wind farms. This model has been built to resist to wind of Class 1 (see Table 7.2).

The GE Haliade 150 6MW wind turbine presents the following characteristics:

Rated power (Prated)	6000 kW
Cut-in Wind Speed (V1)	3.0 m/s
Cut-out Wind Speed (V3)	25 m/s
Wind Class	1b

**Table 7.3:** GE Haliade 150 6MW Characteristics (Retrieved from [ge.com/renewableenergy](http://ge.com/renewableenergy) on 09/06/2020)

The wind turbine start generating power as soon as the wind is blowing faster than 3.0 m/s. For winds above 25.0 m/s, the wind turbine follows an anti-storm procedure and slows the turbine until its complete stop.

These wind turbines are to be installed offshore. If the waters are not shallow enough, floating windmills could be a solution. However, substantial improvements have to be made in this field before implementing floating windmills in such rough conditions. Such windmills have been installed in Japan in order to run some tests. Japan wants to choose RES rather than nuclear and fossil since the Fukushima incident.

Floating windmills could be a game changer in the fight against global warming if we manage to spread the technology across the oceans. The North Sea provides North-

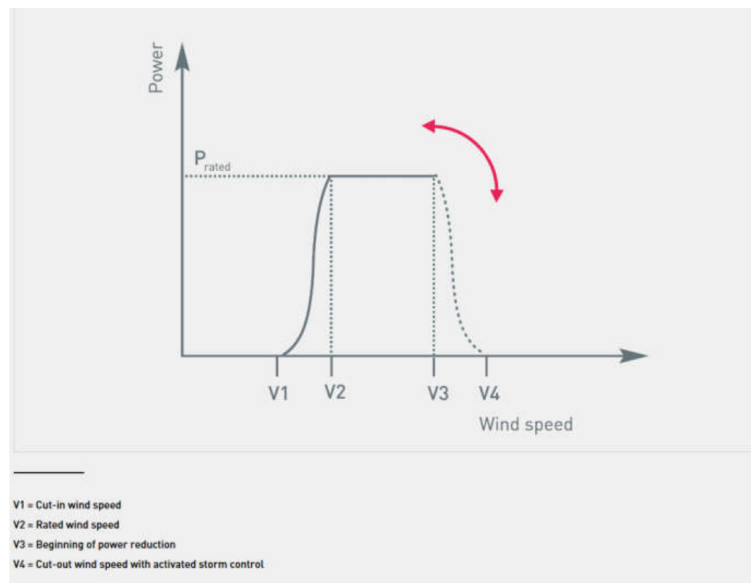

**Figure 7.6:** Generated power

Western European countries a good opportunity to build off-shore wind farms but not every country has such a large area of shallow waters.

## 7.2 Costs

In this section, we will analyse all the costs relative to the project. A lot of different costs has to be taken into account in order to be complete. The main characteristics of the project are the following:

- 5850 km of 3000 MW capacity cable operating at 800kV from Europe to North America passing by Greenland ;
- 3550 km of Over Head Lines (OHL) in Iceland, Greenland and Canada ;
- 2300 km of subsea cables ;
- a 3000 MW wind farm along the Greenland shores ;
- 2 VSC-HVDC converters with a 3000 MW capacity;
- 300 GE Haliade 150 6MW wind turbines.

### 7.2.1 Station costs

In the future, all the installed converters are expected to be VSC converters. They allow multiple entries and exits and is thus a perfect node for the development of the global grid. Furthermore, VSC technology allows the operator to change instantly the direction of the flow while other technologies require a flow reduction 1 hour before and after the flow direction changes. However, VSCs are not yet able to deal with very high capacity (maximum 2000 MW) while other converters technologies as LCC (Line-Commutated Converters) can convert up to 7200 MW. In the literature, it is said that the VSCs capacity is expected to double in a near future.

VSCs have already been used a lot. The literature reports numerous realised and commissioned projects which use this technology.

A good estimate of converters cost is to consider 300 M€ per converter. Indeed, several sources corroborate this information. Hammons et al. (1993) assume a price of 301M€ for a terminal of +/- 450kV and 1200 MW. Delucchi & Jacobson (2011) estimate that the cost for converters should stand within the range 200-310 M€. Then, Hauth et al. (1997) suggest that the price for a converter of 1000MW +/- 350 kV is 115 M€ and 242 M€ for a

3000 MW +/- 500 kV converter. Finally, DLR (2006) gives us prices for parameters quite similar to the ones we will use in this project. They assume terminal converters costs at 250 and 350 M€ when operating at 5000MW and respectively 600 and 800kV. All these suggestions lead us to the conclusion that 300 M€ for a converter is a good estimation.

It should also be highlighted that for each converter, one spare transformer must be purchased. In case of transformer breakage, it can take up to 6 months to get a new one. The transformer costs 8% of the converter price.

The price per converter we will use is thus 324 M€. Two converters will be needed, one in Europe and one in North America.

### 7.2.2 Line costs

The line we will use is a 3000 MW submarine cable and OHL. The cable will be brought to the surface only in Europe, in Iceland, in Greenland and in Canada. The cable will have a total length of 5850 km of which 3550 will be OHL and 2300 submarine cables.

The cable will not be brought to the surface neither on Shetland Islands nor on Faroe Islands because of the high costs it will incur. De facto, the laying techniques are such that cables must be buried in the ground if the sea depth is smaller than 600 meters. Burying the cable is very expensive. The burying is performed by a robot named a "ROV" and takes a very long time (see Appendix A2). Cables are sometimes buried up to 10 meters into the ground. In very exceptional cases, some submarine cables have been buried 15 meters into the ground. When burying the cable, the vessel can sail only at the speed of 200 meters per hour (0.2 km/h). For depth deeper than 600 meters, the cable can be simply laid down at the bottom of the ocean. In this case, the boat can sail at around 600 meters per hour (0.6km/h). On top of the laying boats, two others boats are needed: one to open the route (ensuring there is no other boats on the way) and one to close the route (cleaning the eventual waste which could damage the laying robot). On Figure 7.7, we can see how the cable is buried in the sea bottom.

Through the literature, we can find different prices estimations for submarine cables. Hauth et al. (1997) suggests the price of 136 M€/100km for a 1000MW 400kV cable. Also, DLR (2006) assumes maximum costs of 250 M€/km and 180 M€/km for a 5000MW cables respectively at 600 and 800kV. Hammons et al. (1993) proposes a cost in the

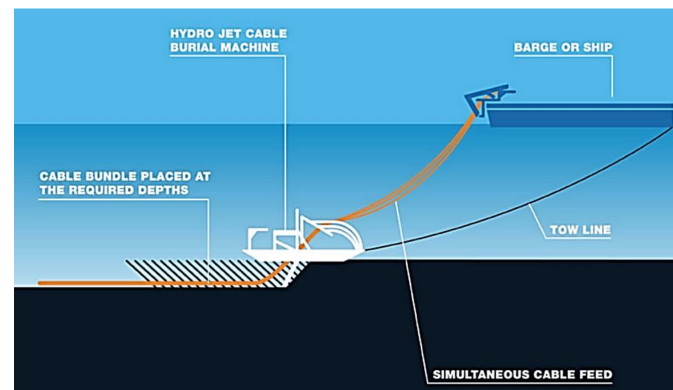

**Figure 7.7:** Cable burying from hudsonproject.com

range 41,9-45,6 M€/100km for a 450kV 600MW cable (including the laying and the transportation).

For OHL, prices are quite constant and can reliably be estimated at 605 €/kV/km. The studied cable will operate at 800kV. We can thus estimate a price of 48.4M€/100km.

The price of the cable depends on three considerable factors. First, the **capacity of the cable** is positively related to the price of the cable. The higher capacity, the larger the cable; the larger the cable, the more metal is needed; the more metal, the more expensive the cable. Second, the **metal choice** is also a decisive factor. Some metals are lighter and cheaper than some others. In general, cables are made of copper but in certain cases, the copper can be replaced by aluminium which is lighter and cheaper for particular segments lying in deep waters. Aluminium has been used instead of copper for the first time in 2012 for the SA.PE.I project in Italy. Third, the **price of the metal** at the time the metal cable is bought has an undeniable impact on the price of the cable given the high quantity of metal needed to build the cable.

To increase the power of the cable by 20% (all other things being equal), the weight increases by 10% and the price increases by 10% as well.

Before laying the cable, a deep analysis of the bottom of the ocean is crucial. We estimate the cost of the analysis at 1% of the cable price. If the analysis is not thorough, some problems can be encountered when laying the cable, resulting in a high increase of costs.

Many types of cable structures can be envisioned. It turns out that bi-polar cables are the most appropriate for this project. Its almost zero impact on the environment is one of the arguments in favour of bi-polar cables.

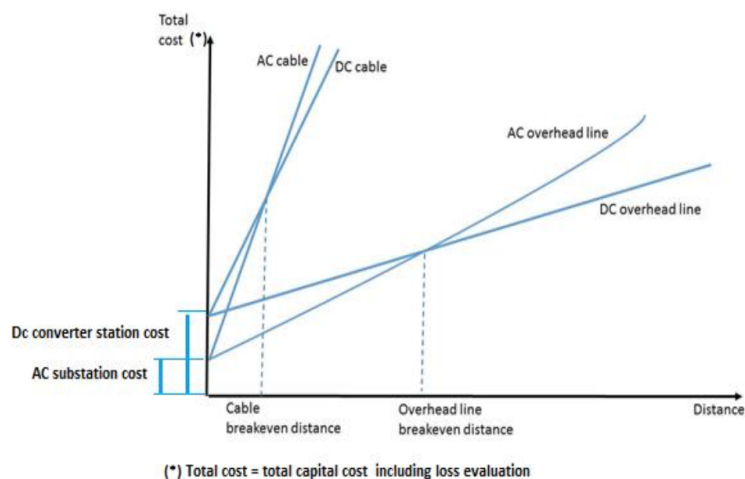

**Figure 7.8:** AC and DC, overhead and submarine cables costs (Yu et al. 2019)

The best cable to lay will be DC and will have the largest possible capacity and voltage at the moment the cable will be commissioned, depending on the technological improvements in this field.

### 7.2.3 Integration costs

Documentation tells us to consider the integration costs when analysing the costs of submarine cable projects. Nevertheless, no article tells us about the integration costs of such a project. In this analysis, integration costs will be ignored.

### 7.2.4 Capitalised costs of converter station and DC line losses during the life of the project

When it comes to the transport of electricity on long distances, DC is more advantageous. Indeed, the cable will experience less losses than AC cables.

The submarine cable break-even distance stands around 40-120km. For overhead lines, the break-even distance is around 600km (Figure 7.8). The overhead line break-even distance is expected to become much smaller in the coming years as the total number of HVDC cables around the globe is rocketing. Given the distances of the project, it is obvious that DC cables and lines will be used.

Moreover, DC cables experience fewer losses than AC cables. When operating at high voltage, the cable losses reach 3% every 1000 km. Also, converters experience some losses.

We can estimate the losses at 0.6%.

With a 3000MW capacity cable, we expect the cable to be able to transport 20 TWh/year. The 3000MW wind farm will produce about 10 TWh/year. Half of the production will be sold to Europe and the other half to North America. The remaining 10 TWh will be allocated to power exchanges between the two regions. So, 10 TWh/year will cross the whole cable between Europe and North America (5850 km), 5 TWh/year will be transmitted from Greenland to North America (3700 km) and 5 TWh/year will be transmitted from Greenland to Europe (2150 km). The cable losses will be 1.67 TWh/year for trades between Europe and North America, 0.32 TWh/year for transmissions from Greenland to Europe and 0.54 TWh/year for transmissions from Greenland to North America.

On top of that, the European converter will convert approximately 15 TWh/year and the North American one too. This will lead to 180 MWh/year of losses due to converters. This brings the sum of the losses to a total of 2,71 TWh/year.

Depending on the electricity prices, these losses can be more or less consequential.

The high voltage (800 kV) and capacity (3000MW) of the cable keep the losses low. If lower capacity and voltage were used, the cable would experience higher losses.

### 7.2.5 Operation & Maintenance costs

Based on actual submarine cables, O&M (Operation and Maintenance) usually costs 5% of the investment costs. Operation costs refer to the costs linked to the smooth running of everyday transmissions while maintenance costs refer to the costs of keeping the material working correctly and fixing the materials in case of defaults.

In general, accidents are unusual. Most of the time, they happen in areas where it is easy to intervene (max 50 meters depth). However, if the cable breaks at great depths, the fixing will be very costly. As of today's date, no break up in submarine cables have occurred at depth greater than 200 meters. The risks of default will decrease over time as we will improve our techniques to find optimal routes and we will have better cable laying protections.

HVDC cables have lower O&M costs than HVAC cables.

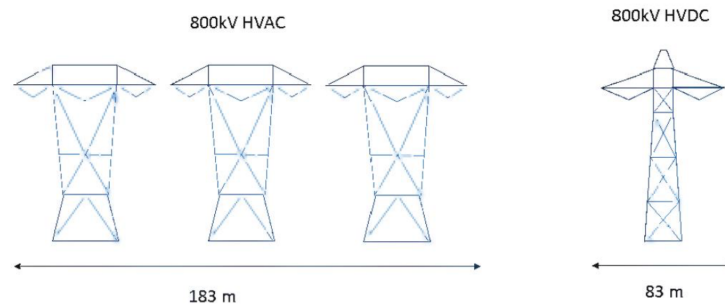

**Figure 7.9:** HVAC and HVDC transmission lines width for the same voltage (Yu et al. 2019)

### 7.2.6 Land acquisition and right of way

In Europe, implementing new windmills and new OHL can be difficult notably because of NIMBY issues (Not In My Back Yard). People are often reluctant to welcome new windmills and OHL near their houses. They assert that it can have a negative impact on their life. Delucchi & Jacobson (2011) argue that NIMBY issues can double the costs of a line. This assumption seems to be largely overestimated.

In this context, the cable will most of the time cross sparsely populated areas, which should not be problematic regarding NIMBY issues. Moreover, the submarine segments of the cable necessitate neither land acquisition nor right of way.

Using HVDC induces lower right of way costs. De facto, as we can see it on Figure 7.9, a 800 kV HVAC line requires three transmission towers and is 183 meters large while a HVDC line with the same voltage is 100 meters narrower and requires only one transmission tower.

### 7.2.7 Wind farm in Greenland

As it has been said above, we will install 300 GE Haliade 150 6MW wind turbines at 100m height to create a 1200 MW wind farm. These wind turbines are able to produce 33 GWh/year. As a production of 10 TWh/year is forecast, 300 of these wind turbines will be installed around site suggestion 6 (Figure 7.5).

Usually the cost structure of a wind farm can be split as follows on Figure 7.10. Also, we can usually estimate the costs at 3 M€ per installed MW.

It is very difficult to give a price for a wind farm along the coasts of Greenland because

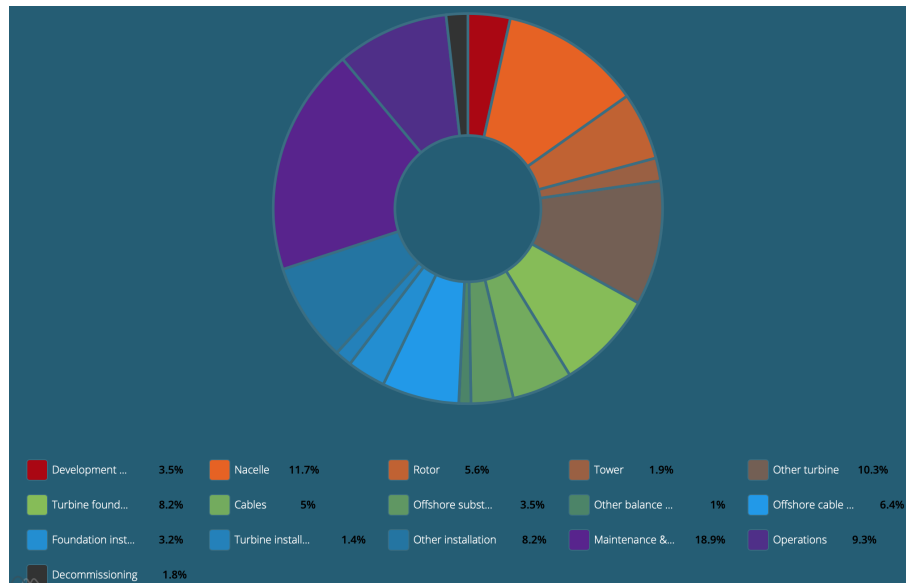

**Figure 7.10:** Costs split for a typical wind farm. Retrieved from [guidetoanoffshorewindfarm.com](http://guidetoanoffshorewindfarm.com). Full names of the categories: Development and Project Management, Turbine Foundation, Foundation Installation, Decommissioning, Nacelle, Cables, Turbine Installation, Rotor, Offshore Substation, Other Installation, Tower, Other Balance of plant, Maintenance and service, Other Turbine, Offshore Cable Installation, Operations

a project like this one has never been realised before. Wind farm so far from inhabited coast has never been built. We are building wind farms in the North sea. The furthest is located at 45 km from the coasts. However, in the Greenland situation, the wind mills will have to be brought from Europe or North America and travel around 3000 km by boat before installation.

The high distances will increase consequently the maintenance and service, operations, the foundation installation, the turbine installation and the decommissioning.

This kind of wind turbines has been used in the "Mercur Offshore Wind Farm" in the German part of North Sea (see Appendix A3). A 396MW capacity has been installed (66 3MW wind turbines) at 45 km from the shores. The total cost of the project was 1.6 bn€. Our project is 4.5 times bigger in terms of amount of wind turbines. The total cost will at least be 4.5 times more expensive. On top of that, we will have to take into account the distance we need to sail to bring all the material on site.

One windmill can be assembled everyday. Given that 300 wind turbines will be built, the length of the installation project can take up to two years. Difficult meteorological conditions can slow the installation even though the boats are equipped to be able to

assemble wind turbines by high winds conditions. One boat will stay along the Greenland shores to perform the installation and other boats will bring the necessary materials to build the windmills. Some ships are specially designed to transport windmills in high quantities (United Heavy Lift and United Wind Logistics for example) (see Appendix A4. One of United Heavy Lift boats is able to transport 156 blades at once. A boat from High Wind Logistics is able to transport 8 turbines and 8 towers. One crane should be brought to the closest harbour so this type of boats can be unloaded and the crane can load the equipment on the installing boat.

The costs (excluding the transportation of the materials, which I can not estimate) should range 8-10 bn€. The transportation will be very expensive as it will take a lot of time and requires specific skills and equipment. It will take around one week (3000 km at 20km/h) for boats to reach Greenland offshore site from North America or Europe. Also, one-week time is needed to load 156 blades on such boats.

## 7.3 Benefits

### 7.3.1 Electricity production from the wind farm

Chatzivasileiadis et al. (2013) estimate that the production of the wind farm (around 10 TWh/year) will be split as follows: 4822 GWh/year will be transmitted to Europe and 4637 GWh/year to North America (10095GWh/year are thus available for trading). The sales will also be achieved in the area offering the highest SPOT price. Hence, the benefits will be optimal. I do not have access to hourly SPOT prices of the electricity market neither in Europe nor in America. So, it is not possible to calculate the potential benefits from the wind farm electricity production.

If the hourly SPOT price was available to me, I could have known more precisely how the energy distribution would have happened and which benefits we would have had. Anyway, what we can say for sure is that the interconnection and the wind farm will lead to a more economic distribution of energy as the cheap wind power will be sold to the places which needs it the most.

### 7.3.2 Trading between Europe and North America

Purvins et al. (2018) conducted a cost-benefit analysis on social welfare resulting from power exchanges between North America and Europe through a 4000MW capacity cable in 2030. Their analysis showed that the energy transmission occurred almost exclusively from Europe to North America. Indeed, 24.1 out of 27.4 TWh/year are transmitted from Europe to North America. The power flows can be observed on Figure 7.11.

From the Figure 7.11, we can conclude that the cable is not used at 100% of its capacity 100% of the time. Most of the flows go towards North America. The power flow has seasonal characteristics (almost no export to Europe in the summer because of high demand in North America and low demand in Europe).

The shift in daily peaks is favourable to electricity trade between the two regions. As it was said in **subsection 4.1**.

The trade between North America and Europe will also allow the decrease of the use of fossil and biomass fired power plants by 2.9GW. So, the interconnection will allow a

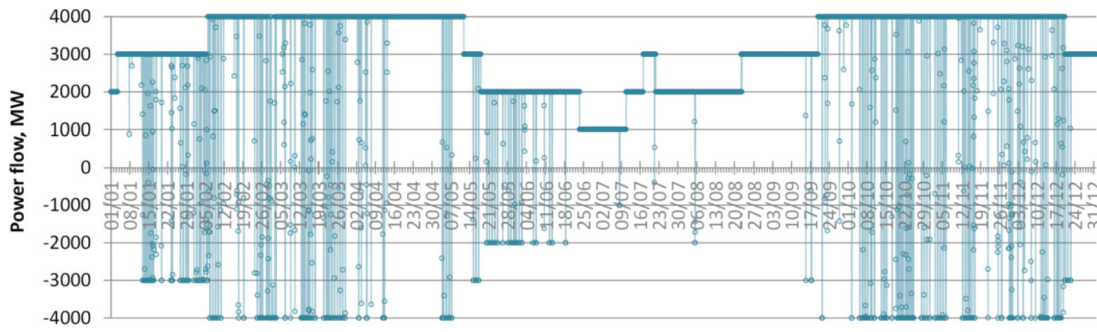

**Figure 7.11:** Power flow in the European cable in 2030 (flow direction towards NA) (Purvins et al. 2018)

decrease in production capacity.

As most of the flow is directed towards North America, we should be aware that Europe will experience higher electricity prices while North America will benefit from lower electricity prices.

The analysis Purvins et al. (2018) conducted is based on the change in social welfare when analysing the situation with and without the interconnection between Europe and North America. They estimated the social welfare as the sum of the consumer surplus, the producer surplus and the merchant surplus:

$$SW_{Region} = CS_{Region} + PS_{Region} + MS_{Region} \quad (7.2)$$

$SW$  Social Welfare

$CS$  Customer Surplus

$PS$  Producer Surplus

$MS$  Merchant Surplus

Region is Europe or North America

$$SW_{TOTAL} = \sum SW_{Region} \quad (7.3)$$

$$\Delta SW_{TOTAL} = SW_{TotalWithCable} - SW_{TotalWithoutCable} \quad (7.4)$$

The result is an increase of 177 M€ per year in Social Welfare if the interconnection is built.

The Social Welfare is varying as shown in Table 7.4. A higher electricity price in Europe will lead to a lower CS and a higher PS. On the contrary, lower prices in North America will lead to higher CS and lower PS. The cable will allow countries with a cheaper cost of electricity to sell their electricity to countries facing high electricity prices.

Chatzivasileiadis et al. (2013) argue that it will be cheaper for the US to buy electricity from cheap RES in Europe during peak demand periods than buying electricity from fossil generation in the US, although the transmission costs increases the price of European RES.

	CS	PS	MS	Total Surplus
Europe	-571	1350	N/A	779
North America	239	-1068	N/A	-829
Total	-332	282	227	177

**Table 7.4:** Effects of the Europe-North America interconnection on social welfare (in M€) (Purvins et al. 2018)

However, the considered cable has a capacity of 4000MW and will only be used for trading electricity between Europe and North America. Within the scope of this thesis, the considered cable only has a capacity of 3000 MW and has 2 roles: transmit electricity from a wind farm in Greenland to Europe and North America and transmit electricity between Europe and North America. We will reduce the transmitted 27.4 TWh/year to the available 10.095 TWh/year available on our 3000MW submarine cable. We can expect the trade to take place in the same proportions. So 88% (8883.6 TWh/year) of the transmitted electricity will flow from Europe to North America and 12% (1211.4 TWh/year) the other way around.

The 10,095 GWh/year are only 36.84% of the 27.4 TWh/year resulting from Purvins et al.'s analysis. The total social welfare increase will thus be decreased by 63.16% (1-0.3684) and equals 65.21 M€/year.

### 7.3.3 Other benefits

Thanks to the interconnection and the time-zone shift, the supply and demand will be smoothed since peak demand periods will not happen at the same time of the day. Peak demands happen twice a day : around 7 A.M. and 7 P.M.. When the morning peak demand begins in Europe, demand is still low in US (East coast) as it is only 1 A.M.. The morning peak demand in the US (East coast) happens when it is 1 P.M. in Europe. The second peak demand in Europe happens when it is 1 P.M in the US (East Coast) and when the second peak demand happens in the US (East coast), it is 1 A.M. in Europe. The interconnection will take advantage of the time zone diversity.

Also, as it has been said, the interconnection will allow a capacity decrease of combustion power plants and lower the needed power reserves.

The low losses experienced by the interconnection and the converters make this project more efficient than pump-hydro storage. Thus, the interconnection decreases the need for power storage.

## 8 Discussion

Through the cost analysis, we discovered that even if the project was very expensive, the already existing technologies make it conceivable and achievable.

Two converters will be needed (one in North America and the other in Europe). Each of them will cost 324 M€. The OHL costs can be estimated quite precisely at 48.4 M€/100km. The 3,550 km of OHL will thus cost 1.718 bn€.

For the submarine cable, it is better to provide two scenarios : a high cost scenario and a low cost scenario. For the high cost scenario, we will use the approximation of DLR (2006) : 1.8 M€/km (estimation given for a 5000MW 800 kV cable). The low cost scenario comes from the SA.PE.I project (one of the most expensive submarine cable in the world). It is set at 1.03 M€/km.

In the high cost scenario, the total cost of submarine cable (2300km) will be 4.14 bn€. In the low cost scenario, the cost will be 2.369 bn€.

The total investment costs will thus be 4.735 bn€ in the low case scenario and 6.506 bn€ in the high cost scenario. Prior to the commissioning of the project, analysis must be carried out. We especially need to analyse the bottom of the sea, and the whole pathway in general. These costs are estimated at 1% of the investment costs (47.35 M€ - 65.06M€). After the realisation of the project, O&M costs will arise. They are estimated at around 5% of the investment costs (236.75 M€ - 325.3 M€).

About the wind farm, the materials and the installation can be estimated between 8 and 10 bn€ regarding the wind turbine model, the number of wind turbines and the installation pace. The O&M costs can be estimated at 3.735 bn€/year.

For the benefits, the only part I can put a figure on is the social welfare increase as a result of electricity trading between Europe and North America. The expected increase in social welfare is 65.21 M€/year.

In this Cost-Benefit Analysis, several costs and benefits could not be estimated :

- The losses in the cables and the converters (I do not have access to electricity prices);
- The benefits from the electricity produced by the wind farm (I do not have access

to electricity prices);

- The land acquisition and right of way costs (I do not have access to any data regarding these costs);
- The transportation costs of the material needed to build the wind farm (This cost is really specific and could not be estimated by myself, it goes beyond the framework of this thesis);
- The building costs of the infrastructure needed on Greenland shores to load and unload the materials;
- The crane rental cost for loading and unloading the materials on the boats on the Greenland shores;
- The environmental benefits stemming from the increased use of RES.

We do not think enough about the time required to complete the project. Currently, 4 to 7 years can pass between the bidding and the commissioning. Some cable manufacturers are full for 3 years. Before commissioning the project, intensive analyses have to be carried out (selection of the provisional path, obtaining permission from the relevant authorities, survey of the path, designing the cable system in order to meet the conditions of the selected path (Ardelean & Minnebo 2015)). When the project will be commissioned, we expect we will have to wait 3 to 4 years before the beginning of the cable manufacturing. Then, the laying of the submarine cable segment can take up to one year since very long distances have to be covered and the laying pace vary between 0.2 and 0.6 km/h. After the laying, a post-lay inspection may be necessary (Ardelean & Minnebo 2015). And finally, other marine users should be notified of the position of the cable.

In total, from the moment the analyses begin to the last step of the project, 15 years might have elapsed.

The future of high voltage transmission lines is promising as the technology is spreading itself around the globe. It is expected in a near future that prices will decrease, capacity will increase and voltage will increase as well. Some technological solutions will be brought so that the current limitations of the technology (maximum length and depth) can be overcome. The depth limitation lengthens the submarine pathway. For very great depths, Purvins et al. (2018) claim that we could lay the cable at 1000 meters and make it stagnate

at that depth by means of a buoyancy system. If this solution appears to be feasible, it would solve the depth issue and radically decrease the cost of the project.

As the technology is spreading, higher volumes will be produced and we could also expect some economies of scale to happen.

Concerning the wind turbines, another option can be considered: onshore wind turbines along the coasts. As the ground is rocky, the fixing costs can be really low. This could be a potential advantage.

## 9 Conclusion

Through this thesis, I have reviewed the feasibility and performed a Cost-Benefit Analysis of a 3000 MW capacity and 800 kV voltage HVDC interconnection between Europe and North America passing by a 1800 MW wind farm in Greenland. Considering all the elements of the analysis, we can say that the project is feasible on a technological point of view. A lot of benefits and a rise of social welfare result from this project. The project is feasible but it is gigantic and very complex. On top of that, it requires enormous investments.

We have to take a step back and realise that the dimensions of this project are not only economical and technical but also social and political.

The project as a whole is gigantic but we have to realise that each segment of the cable is already a very ambitious achievement. It would take years before being fully operational. That's why it is more reasonable to think that the interconnection will be built step by step. Some initiatives are already heading in this direction. For example, Icelink is a submarine cable project between United Kingdom and Iceland. The cable is to be built in 2024. Iceland has a wide RES potential. Furthermore, the potential can easily be doubled thanks to geothermal and hydro energy. United Kingdom installed a 3MW Enercon E82 E4 wind turbine on the Shetland island (North of Scotland). Shetland benefits from excellent wind conditions for wind energy production. This wind turbine, as well as Iceland and its huge RES potential could possibly be part of an Europe - North America interconnection. Faroe Islands could also hope to be part of the project. Therefore, these smaller islands could benefit from a better security supply and we could benefit from their high RES potential.

It makes no doubt that the RES potential from Greenland will be harvested soon or later. The future development in the interconnection field tends towards the realisation of a Global Grid. This Global Grid will be built step by step.

Countries have very different energy policies, carbon taxes policies, etc. It will take time before we come to an agreement about how policies should be dealt with and how costs and benefits should be split between countries.

Then, before such an interconnection could be built, we need to develop local grids to transmit the flows to the nearby load centers. Each end of the interconnection must be able to deal with all the transmitted electricity, local grids should be reinforced in order to support bigger energy flows.

The interconnection should be seen as a project which will benefit to social welfare. The first goal is not to build a for-profit interconnection. Thus, any amortization period shorter than the lifetime of the project should be seen as a positive perspective as it will bring benefits to the society.

The challenge of transmitting electricity between Europe and North America can also be seen under a different approach. A Europe-Asia HVDC overhead line could be built and electricity could be brought to North America through the strait of Bering. This option might be cheaper as only a small segment of the cable would be submarine. However, this option is obviously unrealistic given the political relationships between Russia and the USA. As it was mentioned above, not only economical and technical parameters have to be taken into account. The political and social aspects should also be considered when considering international and global projects.

## References

- Aboumahboub, T., Schaber, K., Tzscheutschler, P., & Hamacher, T. (2010). Optimization of the utilization of renewable energy sources in the electricity sector. *renewable energy resources*, 11, 196–2004.
- Andrew, B., Joachim, L., & Anna, N. (2012). Asia pacific super grid–solar electricity generation, storage and distribution. *Green*, 2(4), 189–202.
- Ardelean, M., & Minnebo, P. (2015). Hvdc submarine power cables in the world. *Joint Research Center*.
- Ardelean, M., & Minnebo, P. (2017). A china-eu electricity transmission link.
- Brinkerink, M., Gallachóir, B. Ó., & Deane, P. (2019). A comprehensive review on the benefits and challenges of global power grids and intercontinental interconnectors. *Renewable and Sustainable Energy Reviews*, 107, 274–287.
- Chatzivasileiadis, S., Ernst, D., & Andersson, o. (2013). The global grid. *Renewable Energy*, 57, 372–383.
- da Silva Soares, J. P. (2016). *Wind energy utilization in arctic climate–racmo 2.3 greenland climate runs project*.
- Delucchi, M. A., & Jacobson, M. Z. (2011). Providing all global energy with wind, water, and solar power, part ii: Reliability, system and transmission costs, and policies. *Energy policy*, 39(3), 1170–1190.
- DLR, G. A. C. (2006). *Institute of technical thermodynamics, section systems analysis and technology assessment, “trans-mediterranean interconnection for concentrating solar power,”* (Tech. Rep.). Tech. Rep., 2006.[Online]. Available: <http://www.dlr.de/tt/trans-csp> . . . .
- DNVGL. (2019). *Energy transition outlook 2019, a global and regional forecast to 2050*. London, UK.
- ENTSO-E. (2020). *Entso-e standardized control interface for hvdc sil/hil conformity tests*.
- Grossmann, W. D., Grossmann, I., & Steininger, K. W. (2014). Solar electricity generation across large geographic areas, part ii: A pan-american energy system based on solar. *Renewable and Sustainable Energy Reviews*, 32, 983–993.
- Hammons, T., Olsen, A., Kacejko, P., & Leung, C. (1993). Proposed iceland/united kingdom power link-an indepth analysis of issues and returns. *IEEE Transactions on Energy Conversion*, 8(3), 566–575.
- Hauth, R. L., Tatro, P. J., Railing, B. D., Johnson, B. K., Stewart, J., & Fink, J. L. (1997). *Hvdc power transmission technology assessment* (Tech. Rep.). Oak Ridge National Lab., TN (United States).
- IEA. (2019a). *China power system transformation*. Paris. Retrieved from <https://www.iea.org/reports/china-power-system-transformation>
- IEA. (2019b). *Sdg7: Data and projections*.

- Jakobsen, K. R. (2016). Renewable energy potential of greenland with emphasis on wind resource assessment.
- MacKay, D. (2009). *Sustainable energy: Without the hot air*. UIT.
- Maruf, H. M., Mitra, B., Sahu, P. K., Manjrekar, M., & Chowdhury, B. (2016). Hybrid high voltage ac/dc system for interfacing off-shore power generations with on-shore grid. In *Southeastcon 2016* (pp. 1–2).
- Navpreet, T., Tarun, M., Amit, B., Kotturu, J., Bhupinder, S., Anant, B., & Gurangel, S. (2012). Voltage source converters as the building block of hvdc and facts technology in power transmission system: a simulation based approach. *Advances in Applied Science Research*, 3(5), 3263–3278.
- NorthSeaLink. (2020). *What is north sea link (nsl)?* Retrieved from <http://northsealink.com>
- Purvins, A., Sereno, L., Ardelean, M., Covrig, C.-F., Efthimiadis, T., & Minnebo, P. (2018). Submarine power cable between europe and north america: A techno-economic analysis. *Journal of Cleaner Production*, 186, 131–145.
- Qin, X., Zeng, P., Zhou, Q., Dai, Q., & Chen, J. (2016). Study on the development and reliability of hvdc transmission systems in china. In *2016 ieee international conference on power system technology (powercon)* (p. 1-6).
- Radu, D., Berger, M., Fonteneau, R., Hardy, S., Fettweis, X., Le Du, M., . . . Ernst, D. (2019). Complementarity assessment of south greenland katabatic flows and west europe wind regimes. *Energy*, 175, 393–401.
- Reynolds, M. (2012). Tres amigas super station-large scale application of vsc back-to-back technology. In *Pes t&d 2012* (pp. 1–5).
- Rosa, E. A., & Dietz, T. (2012). Human drivers of national greenhouse-gas emissions. *Nature Climate Change*, 2(8), 581–586.
- Yu, J., Bakic, K., Kumar, A., Iliceto, A., Beleke Tabu, L., Ruaud, J., . . . others (2019). Global electricity network-feasibility study.

# Appendix

## A1 Cable boats

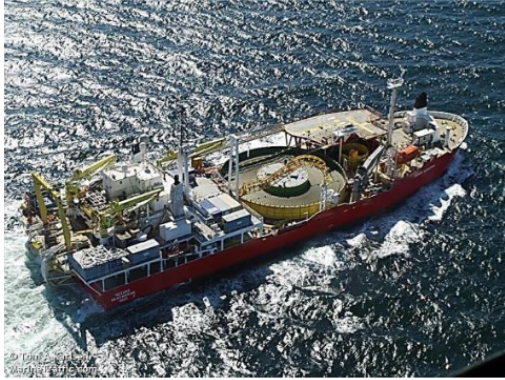

Skagerrak (Nexans)



Giulio Verne (Prysmian)



Team Installer a.k.a. Team Oman (Topaz Energy and Marine)



C.S. Sovereign (Global Marine Systems Ltd)

**Figure A1.1:** Cable laying boats from the 4 main cable laying companies

## A2 ROVs (Remotely Operated Vehicles)



Nexans's CAPJET trenching system



Fugro's trenching system



Prysmian's hydroplow

**Figure A2.1:** Example of ROVs

## A3 Offshore Windmill construction



**Figure A3.1:** Picture of the assembly of an offshore GE Haliade 150 6MW in the Merkur wind farm in North Sea

## A4 High Wind Logistics' boats

Long-term business relationships through customer satisfaction



### MV BOLDWIND

Deadweight 10.000 tons

Deck 128,1 x 28,0 m

Length Overall 148,5 m

GT / NT 8.816 / 2.645

Deck Strength 20 MT/m<sup>2</sup>

Service Speed 12,0 kn

Design Draft 5,6 m

**UWL**  
**DECK CARRIER**



UNITED WIND LOGISTICS GmbH | wind@unitedwindlogistics.de | +49 40 30 85 42 470 | Details are given in good faith but without guarantee of accuracy or completeness (01/2020)

Figure A4.1: MV BOLDWIND

Long-term business relationships through customer satisfaction



### MV VESTVIND

Deadweight 10.000 tons

Deck 107,9 x 25,0 m

Length Overall 130,0 m

GT / NT 7.175 / 2.153

Deck Strength 20 MT/m<sup>2</sup>

Service Speed 10,0 kn

Design Draft 5,3 m

**UWL**  
**DECK CARRIER**



UNITED WIND LOGISTICS GmbH | wind@unitedwindlogistics.de | +49 40 30 85 42 470 | Details are given in good faith but without guarantee of accuracy or completeness (02/2020)

Figure A4.2: MV VESTVIND

**UNIVERSITÉ CATHOLIQUE DE LOUVAIN**  
**Louvain School of Management**

Place des Doyens, 1 bte L2.01.01, 1348 Louvain-la-Neuve, Belgique | [www.uclouvain.be/lsm](http://www.uclouvain.be/lsm)