



Visible

Fabriques historiques



Carrières à ciel ouvert



Boites industrielles



Paysage hydrolique



Invisible

**F**  
 «En 1997, Onda comptait 60 fabriques, la plupart en centre-ville»  
 Extrait de 'la Indústria cerámica de Onda' de Vicent Joan Estall i Poles, paru en 1997.  
 Le complexe unissant la Campaneta, Bopisa et la Giralda représente  
 51 256 m<sup>2</sup> d'espaces actuellement en ruines.»

**C**  
 «Les carrières actuellement exploitées peuvent poursuivre leur activité à condition de respecter les dispositions de la loi 4/92 sur les terrains non bâtis.»  
 «Le ministère de l'agriculture a accordé une évaluation environnementale favorable à la nouvelle exploitation d'extraction d'argile de Mancilla. (...) La generalitat apporte un soutien clair au secteur en cette période d'incertitude due aux effets de la guerre en Ukraine (...)»  
 Extrait d'un article d'El Diarito paru dans l'édition de Mai 2022

**I**  
 «Les terrains classés comme industriels (1 095,5 ha) représentent le double de la superficie des terrains destinés à un usage résidentiel (495,7 ha).»  
 «Les polygones occupent une surface totale de 10 836 389 m<sup>2</sup>.»  
 Extrait du plan Onda 2030 rédigé par la commune en décembre 2023

**E**  
 «En 2016, la province de Castellón était responsable de 27,2 % de la consommation totale d'énergie dans la Communauté Valencienne.»  
 Ainsi, la province de Castellón, la plus faiblement peuplée de toute la région (11,6 %) a une demande d'énergie très similaire à celle d'Alicante, dont la population est 3,2 fois plus importante.»  
 Extrait du plan Onda 2030 rédigé par la commune en décembre 2023.

HAB COM	ESPACES DE SUPPORT AGRICOLE	HAB COM	PARC	HAB	PEPINIÈRE				
EXT		EXT		INT EXT					
TOUS	<i>aménagement paysager</i>	TOUS	<i>meubler urbain</i>	TOUS	<i>espace de culture</i>				
JOUR NUIT		JOUR NUIT		JOUR NUIT					
SOLS		SOLS	<i>aménagement paysager</i>	RES	<i>stockage</i>				
+		+		+					
HAB COM	CAFÉ DU COIN	HAB	RESTAURANT DES OUVRIERS	HAB	BAR DU VILLAGE	COM	NOUVEAUX LOGEMENTS	HAB COM	CABINET MÉDICAL
INT EXT		INT EXT		INT EXT		INT		INT	
TOUS	<i>espace de restauration</i>	EMP TOUS	<i>espace de restauration</i>	TOUS	<i>bar</i>	HAB	<i>espaces privés</i>	TOUS	<i>salle d'attente</i>
JOUR		JOUR		JOUR NUIT		JOUR NUIT		JOUR	
PLAN	<i>terrasse</i>	IND	<i>terrasse</i>	BRUIT	<i>terrasse</i>	PRIV	<i>espaces partagés</i>	VILLE	<i>cabinet</i>
50		50	<i>cuisine</i>	50		100	<i>accueil</i>		
	<i>cuisine</i>				<i>espace de restauration</i>				
HAB	MUSÉE DE LA CÉRAMIQUE	HAB COM	SALLE DES FÊTES	HAB	RESTAURANT	HAB	CINÉMA		
INT EXT		INT EXT		INT EXT		EXT			
TOUS	<i>espace d'exposition</i>	TOUS	<i>lieux de réunion</i>	TOUS	<i>cuisine</i>	TOUS	<i>mur où projeter</i>		
JOUR		JOUR NUIT		JOUR NUIT		NUIT	<i>sol ou s'asseoir</i>		
ART	<i>archives</i>	BRUIT	<i>stockage</i>	BRUIT		ISO			
+	<i>bureaux</i>	+		100	<i>terrasse</i>	+	<i>kiosque pour manger</i>		
HAB COM	CENTRE DU SUPERVISION DES INDUSTRIES	HAB COM	LABORATOIRE DE RECHERCHE SUR CÉRAMIQUE	HAB	LIEU D'APPRENTISSAGE MÉTIERS TRADITIONNELS	HAB	FERME-ÉCOLE		
INT		INT EXT		INT EXT		INT EXT			
PRO	<i>bureaux</i>	PRO	<i>bureaux</i>	TOUS	<i>ateliers</i>	PUB	<i>lieux d'enseignement</i>		
JOUR		JOUR		JOUR		JOUR			
IND	<i>lieux de réunion</i>	PLAN	<i>cafétéria</i>	PLAN	<i>lieux d'exposition</i>	PRO			
+		+	<i>laboratoire</i>	+	<i>lieux de réunion</i>	400	<i>lieux de rangement</i>		
	<i>cafétéria</i>								

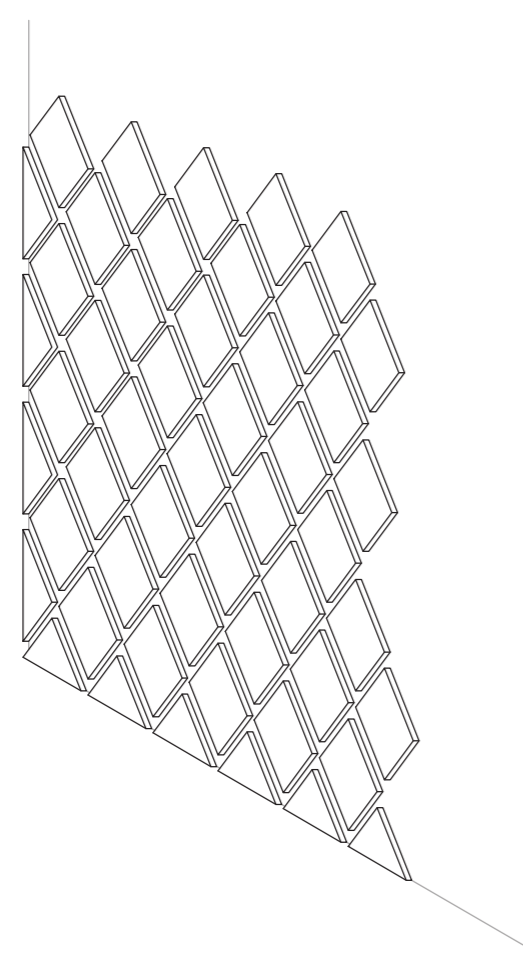

Musée Z33  
Hasselt, Belgique  
Francesca Torzo  
2019

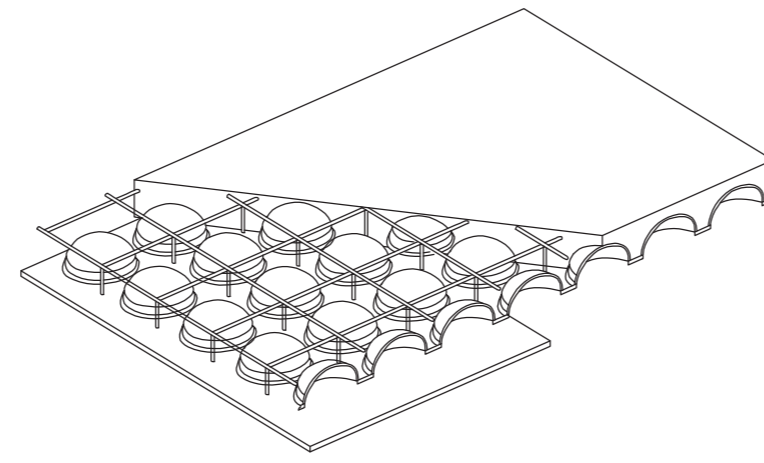

Wall House  
Auroville, Inde  
Anupama Kundoo  
1997

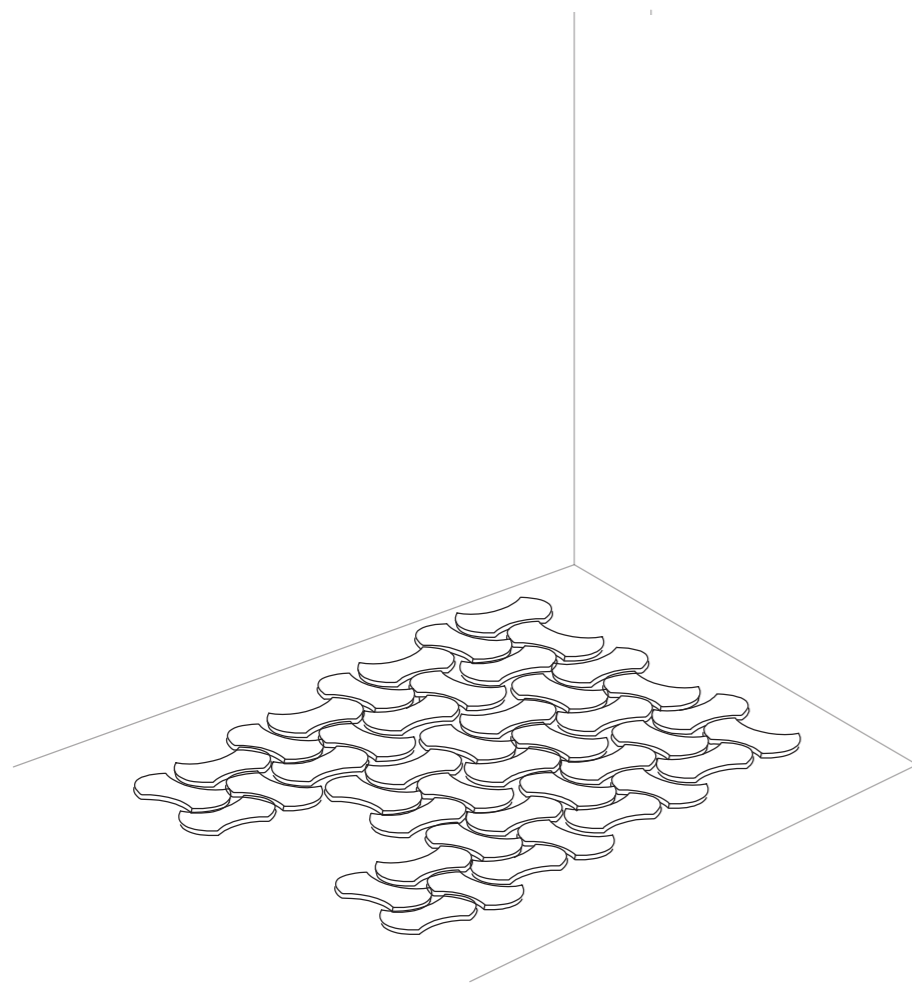
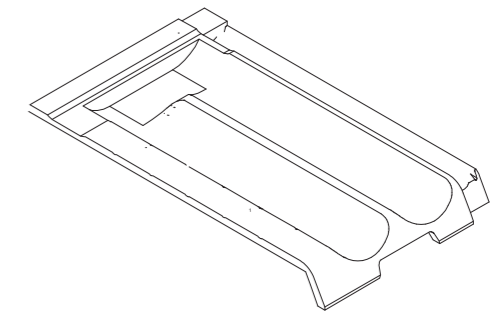
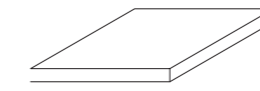
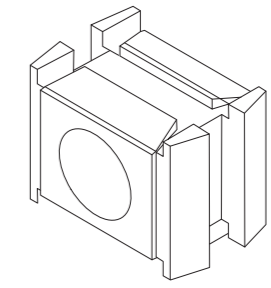
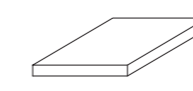

Fondation Maeght  
Saint Paul de Vence, France  
Joseph Louis Sert  
1964

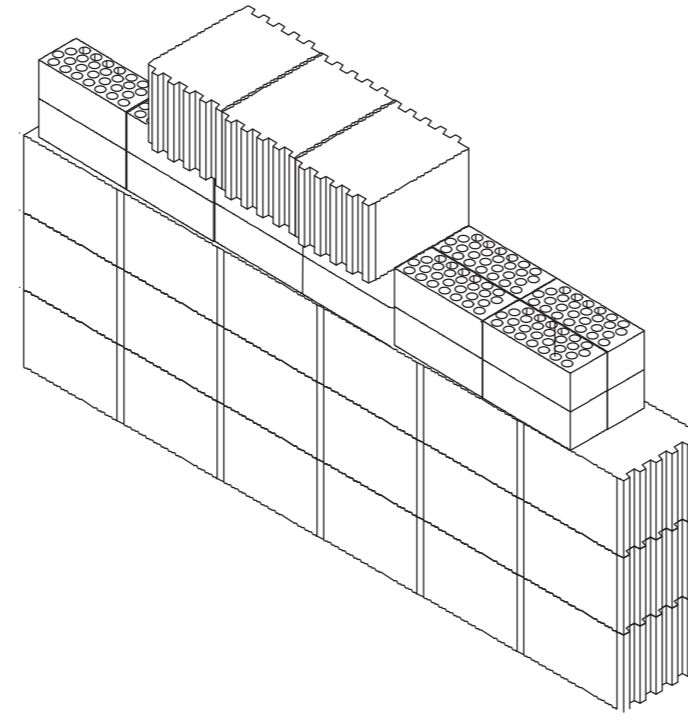

Casa en tres primaveras  
Teruel, Espagne  
David Sebastian  
2012

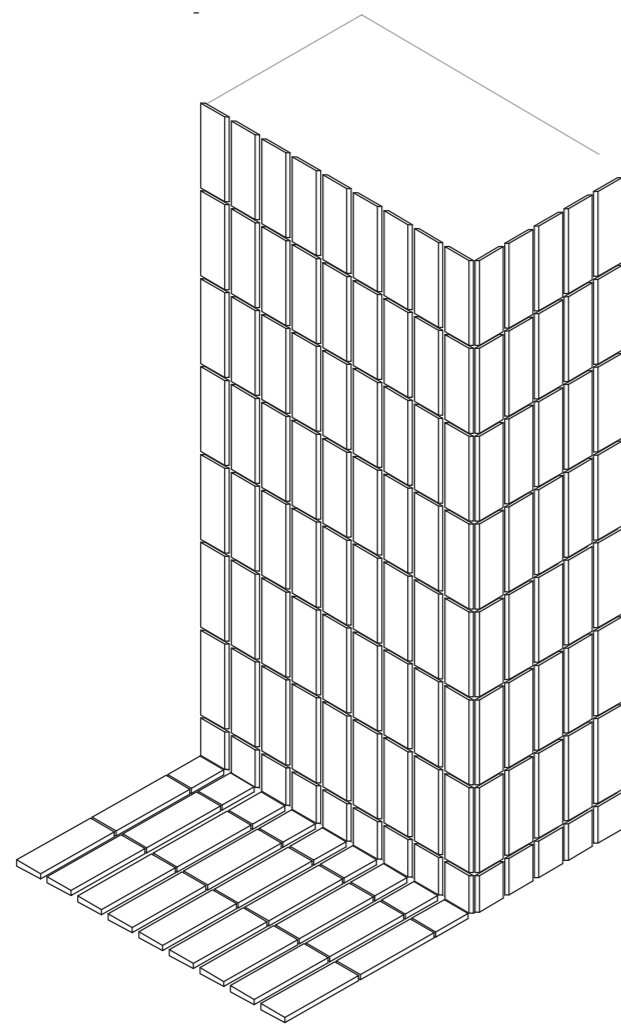
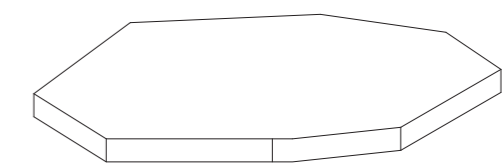
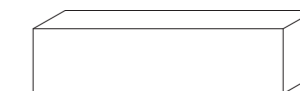
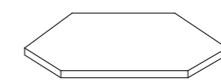
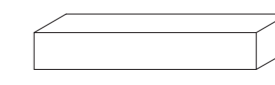
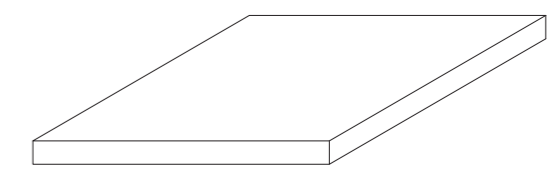
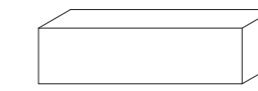

Casa en Mont-Ras  
Mont-Ras, Espagne  
Ricardo Bofill  
1973

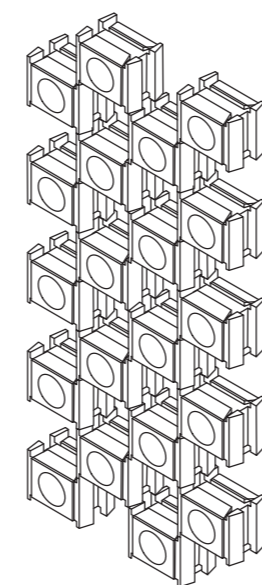

Casa Gomis  
Barcelona, Espagne  
Antoni Bonet  
1953

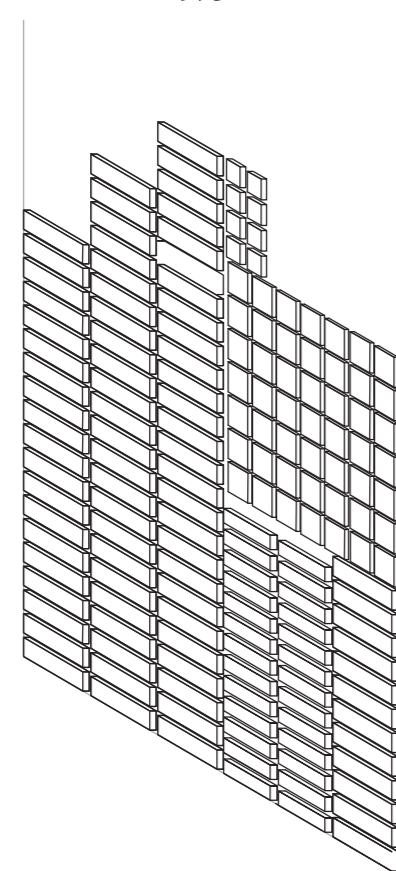
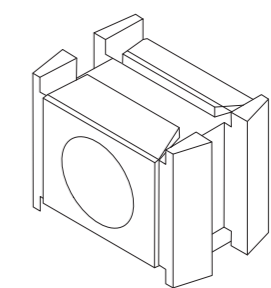
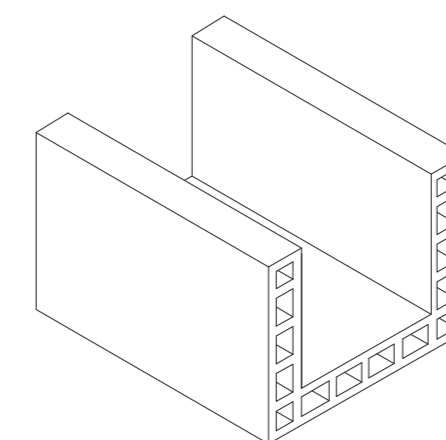
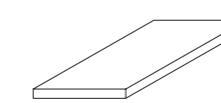

House in Muuratsalo  
Muuratsalo, Finlande  
Alvar Aalto  
1952

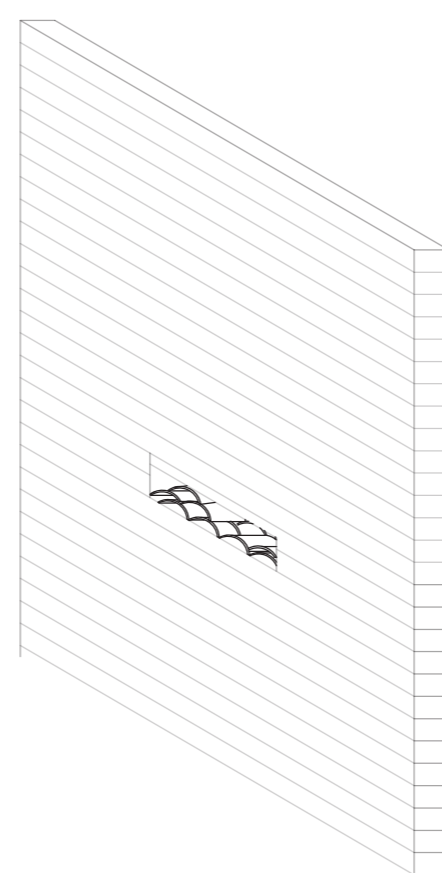

Ningbo Museum  
Zhejiang, Chine  
Wang Shu  
2007

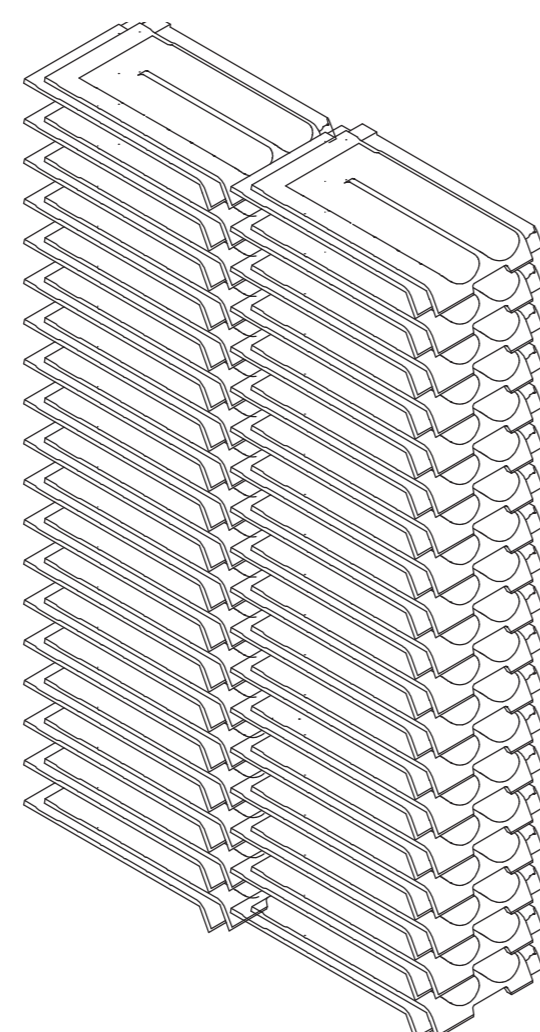
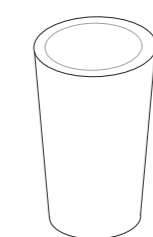
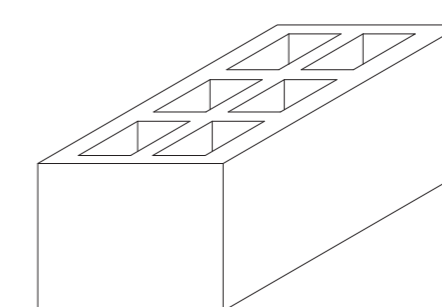
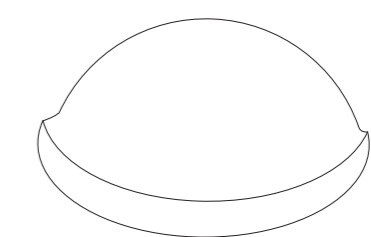
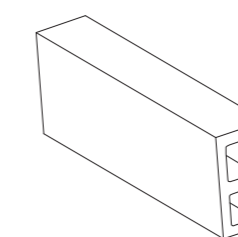
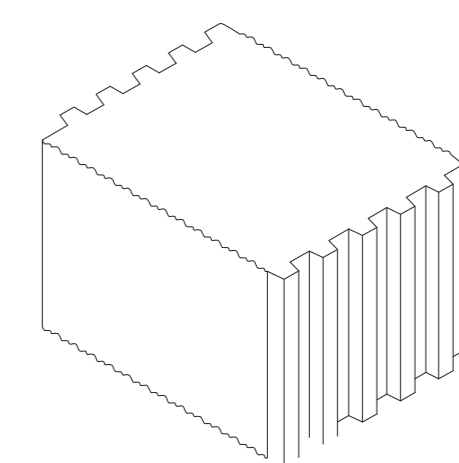
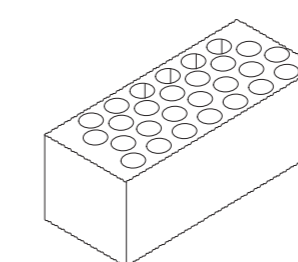

Warehouse 8B  
Madrid, Espagne  
Arturo Franco  
2009

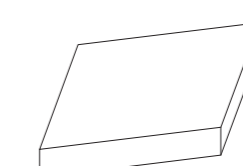
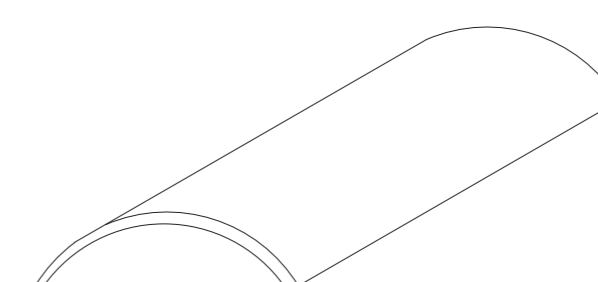

Pièces manipulées  
Experimentation des éléments

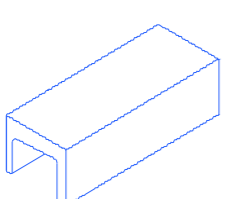
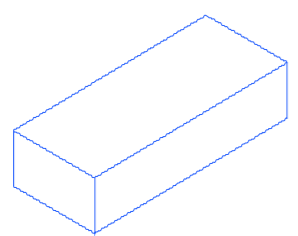
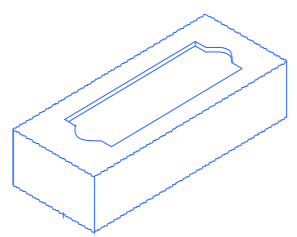
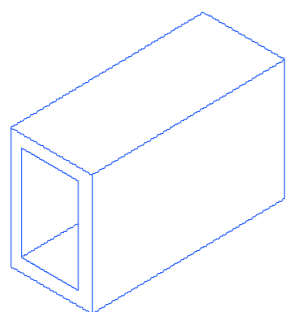
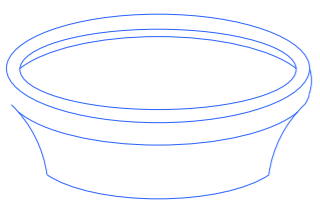
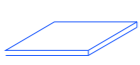
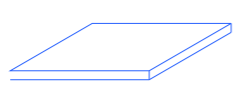
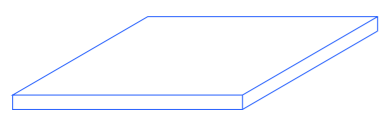
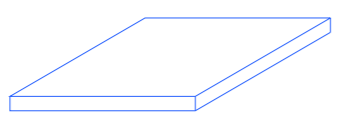
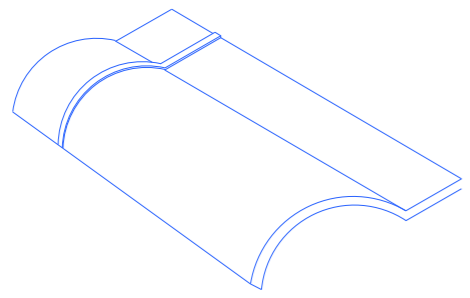
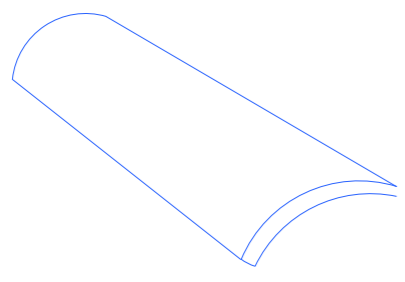
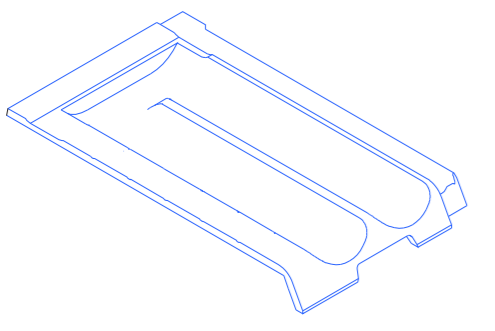

Pièces disponibles  
Experimentation des éléments

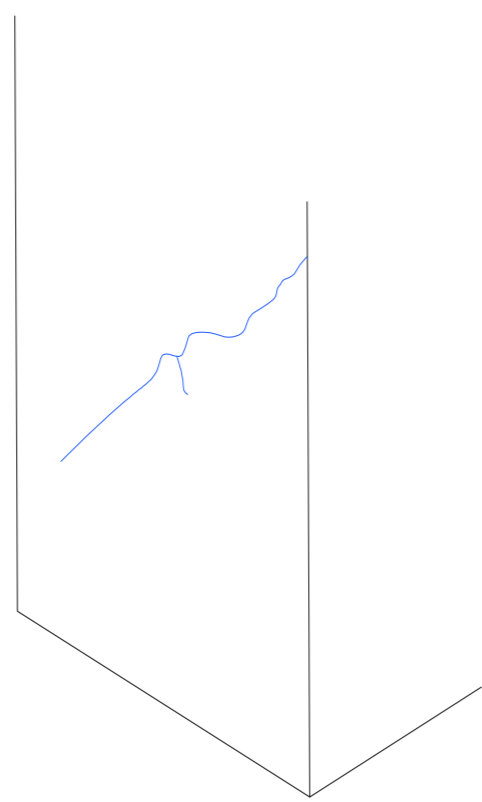

Fissures  
Réparation par un enduit à la chaux et résolution de la cause.

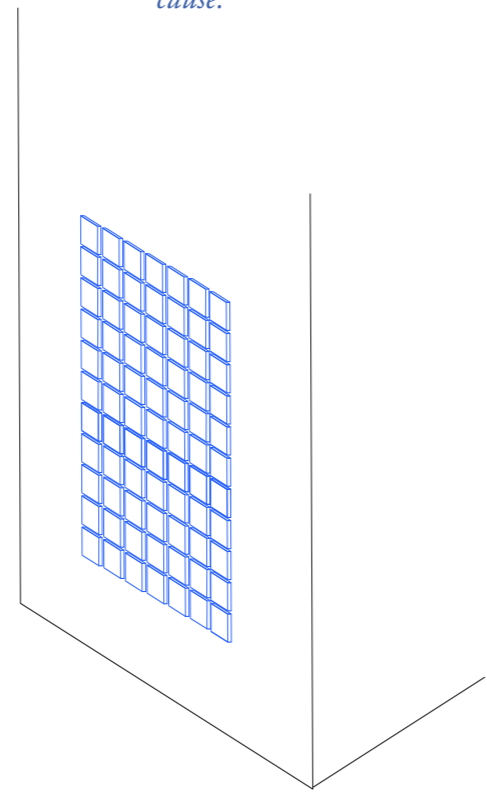

Remplissage  
Maintenir la condamnation et la carrelé en utilisant les trouvaillés

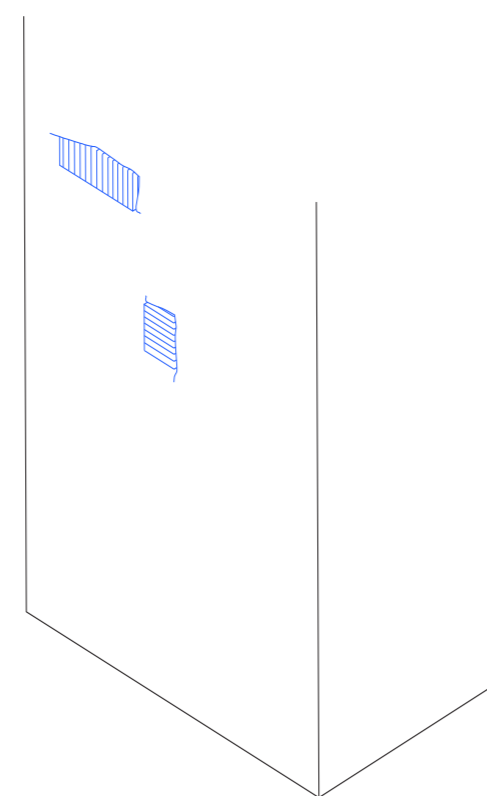

Matériaux perdus  
Comblé les vides avec les carreaux à la manière dont la fabrique a déjà été comblée à certains endroits, les éléments sont empilés et forment un nouvel appareillage.

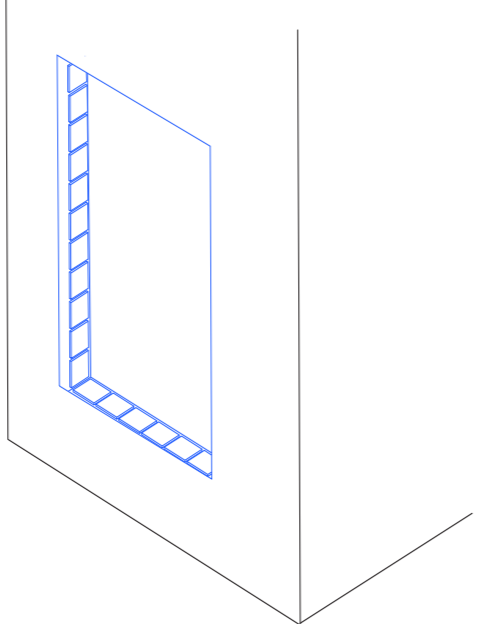

Éléments démolis  
Double possibilité : maintenir la démolition ou remplacer les pièces manquantes.

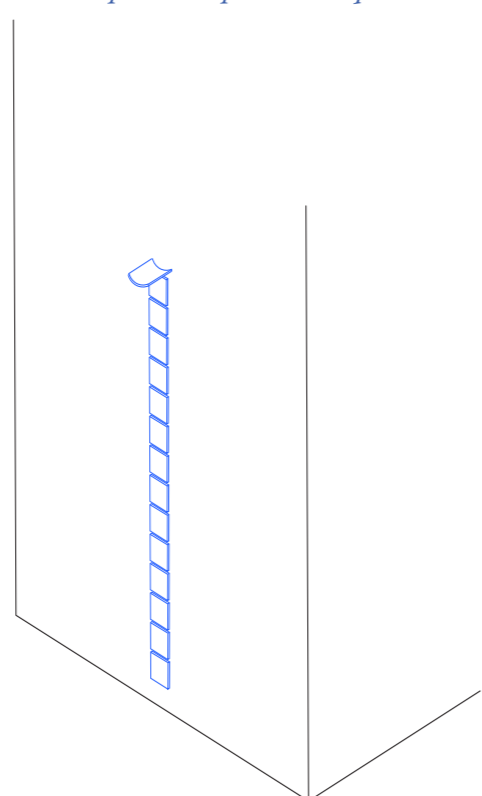

Fuites et ruissellement  
Réparer les corniches et tête de mur, retravailler l'évacuation des eaux

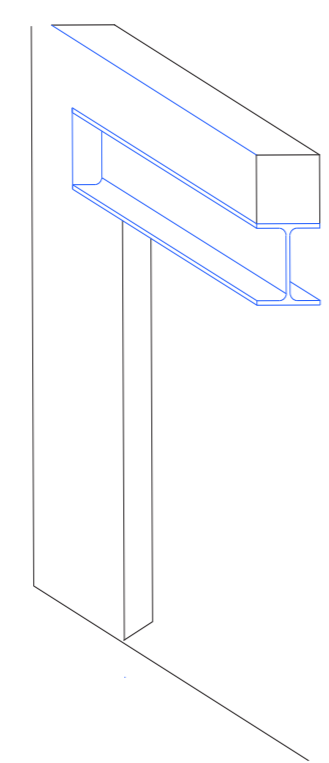

Remplissage  
Rouvrir et y intégrer un élément structural lorsque c'est nécessaire

Arriver sur le site,  
4 entrées horizontalement

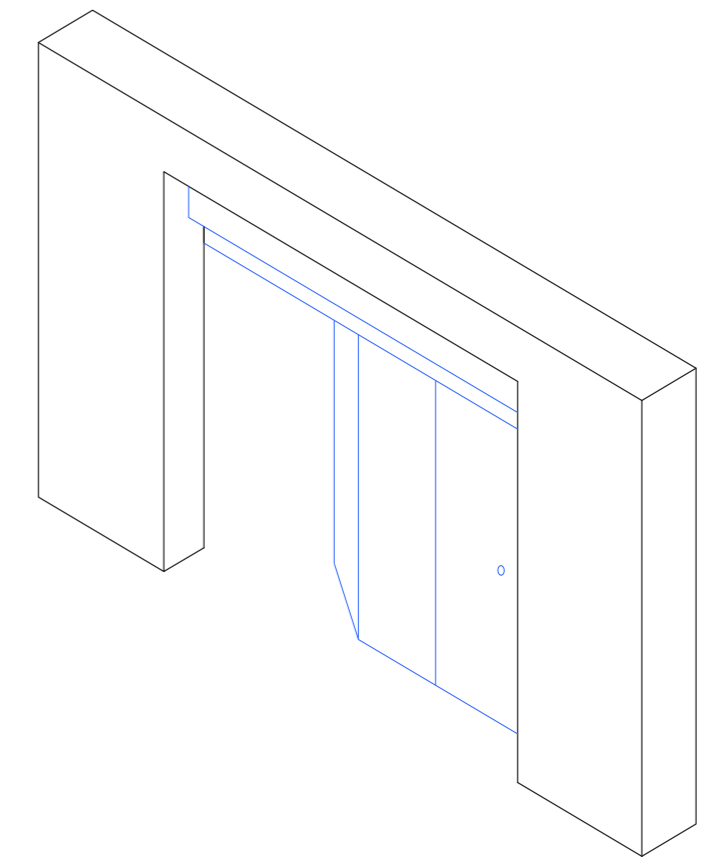
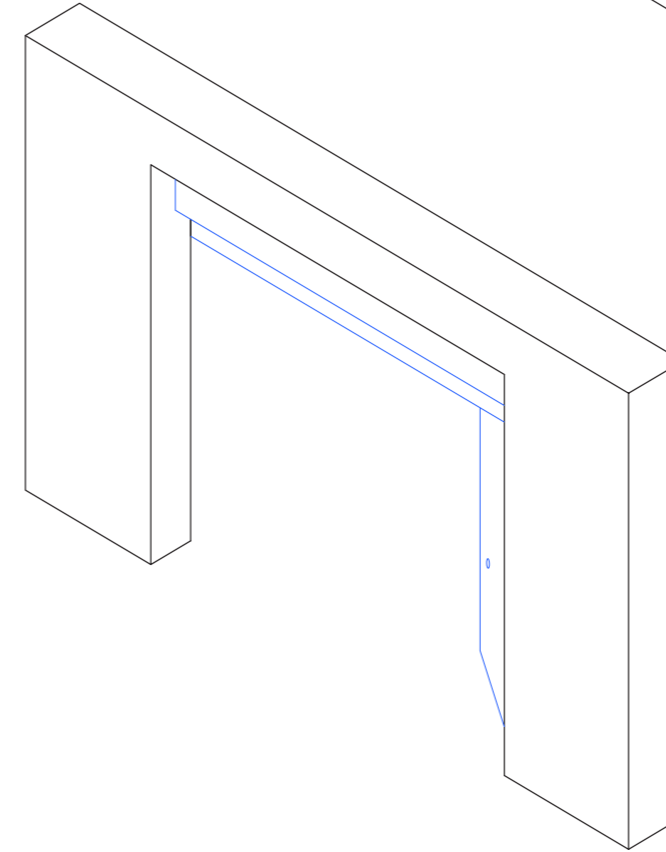
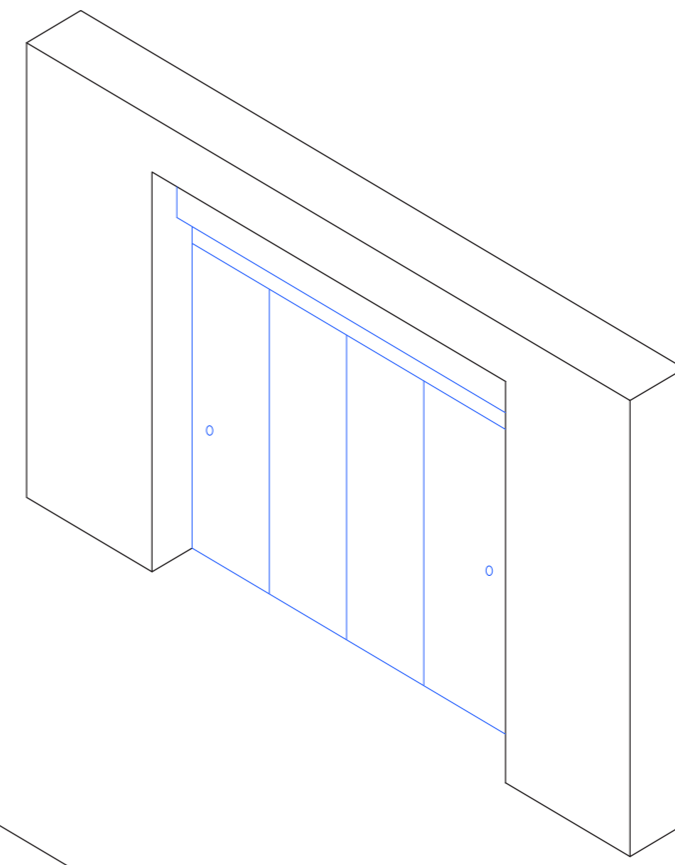

Arpenter les différents espaces,  
cloisons, portes, fenêtres

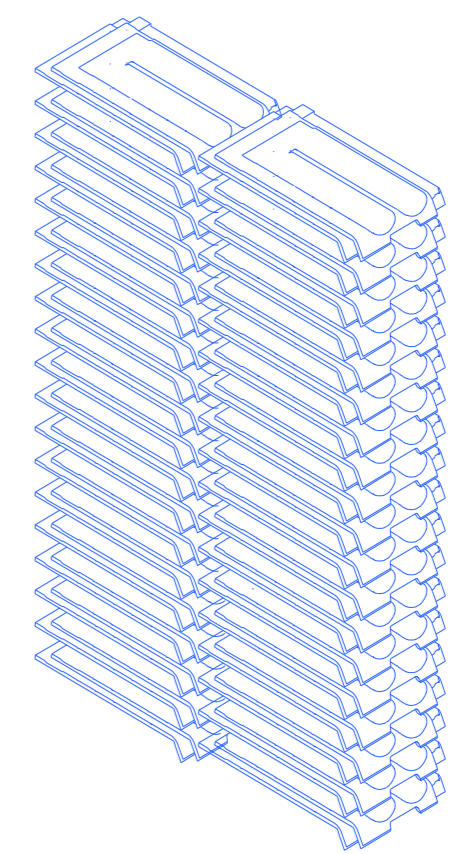
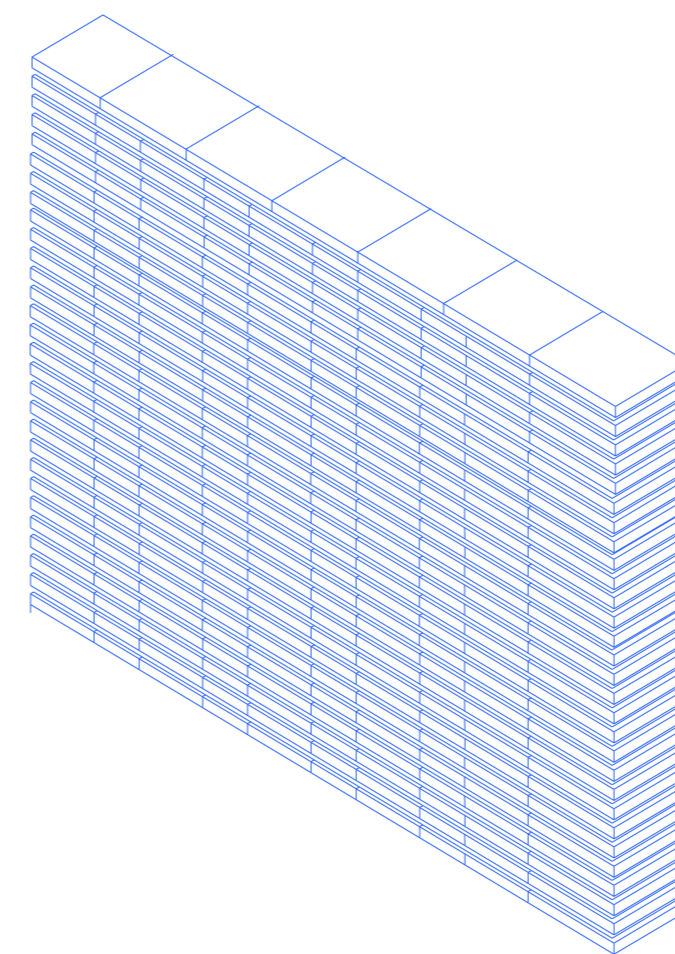
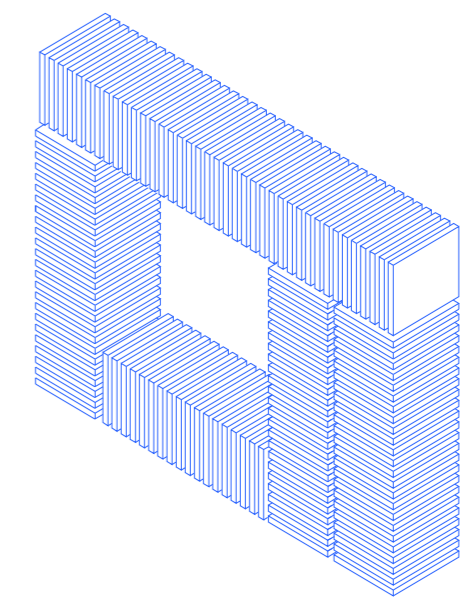
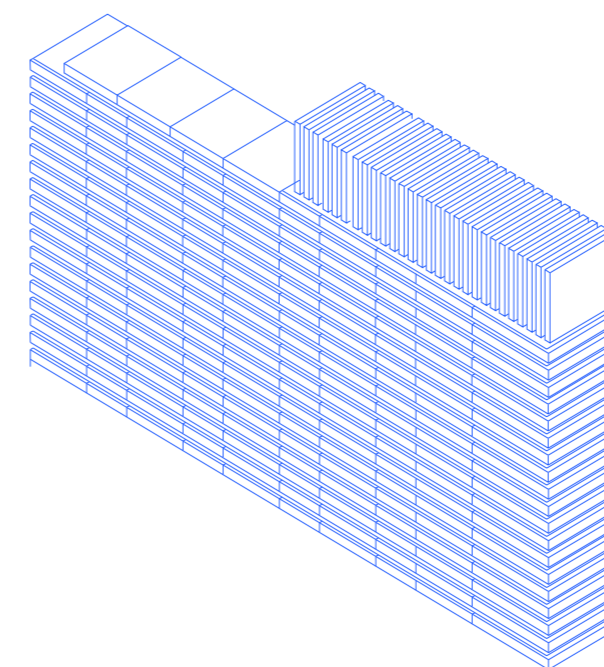

Se déplacer dans la fabrique  
verticalement

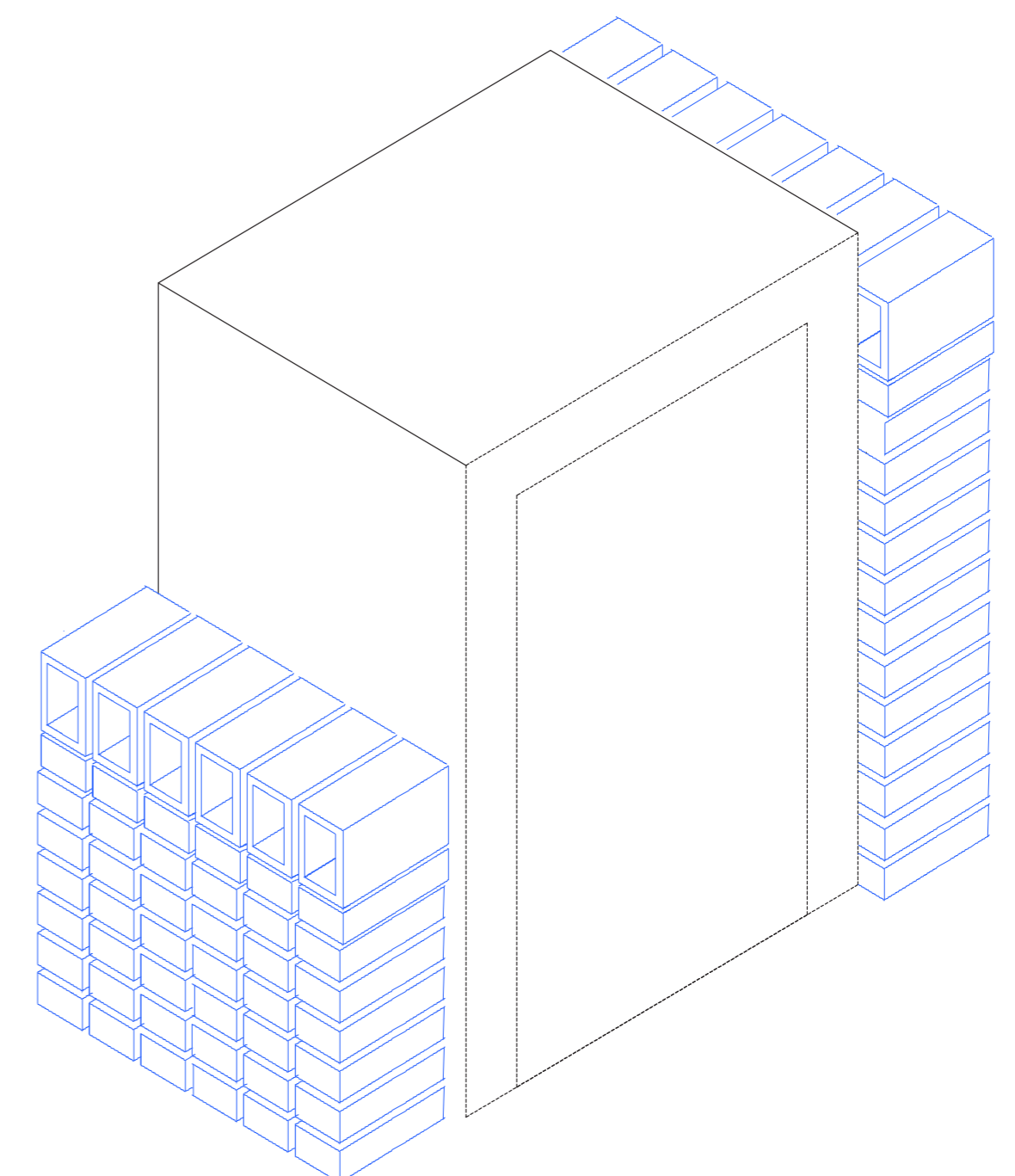
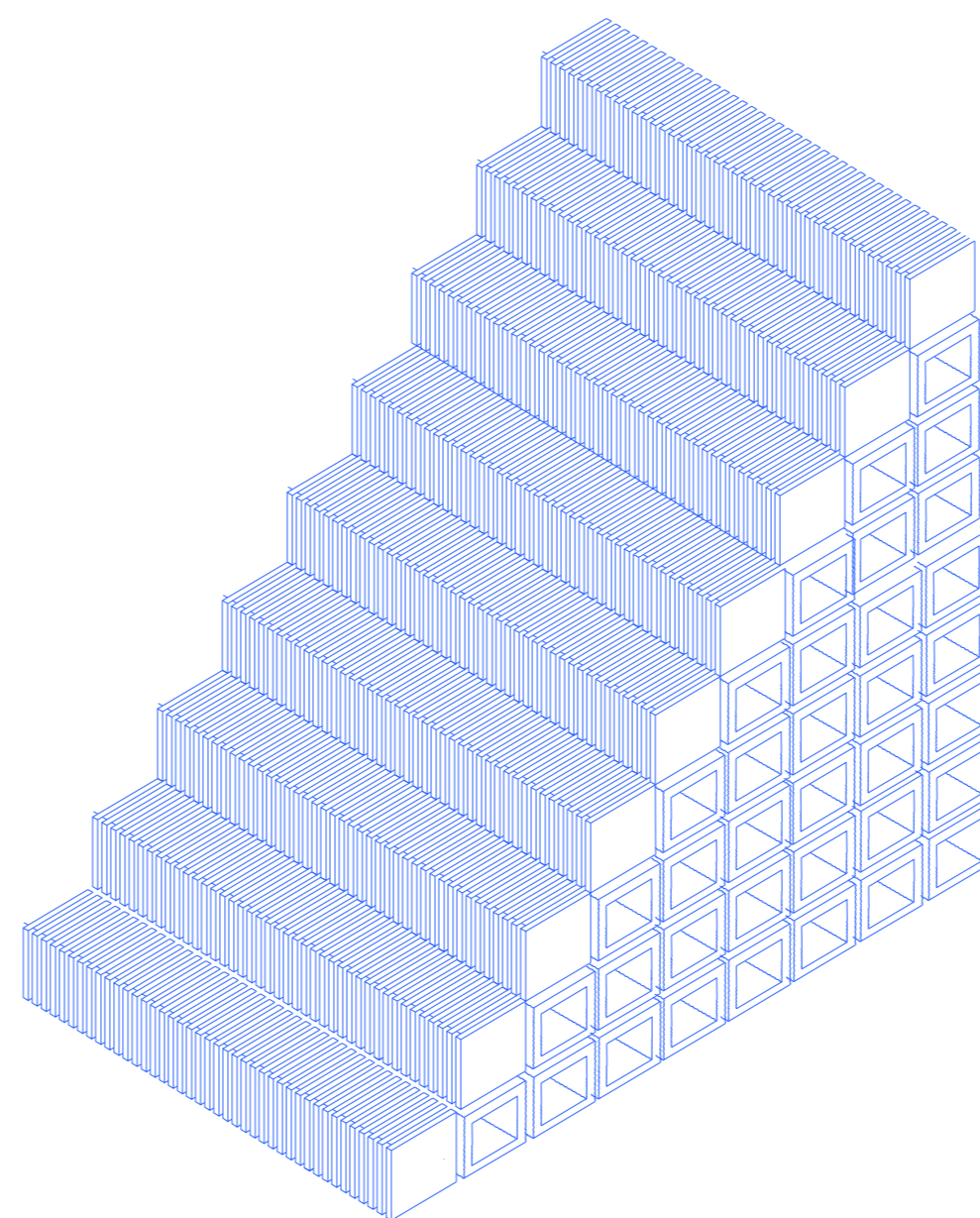

*Habiter par l'intensité*  
*Assises*

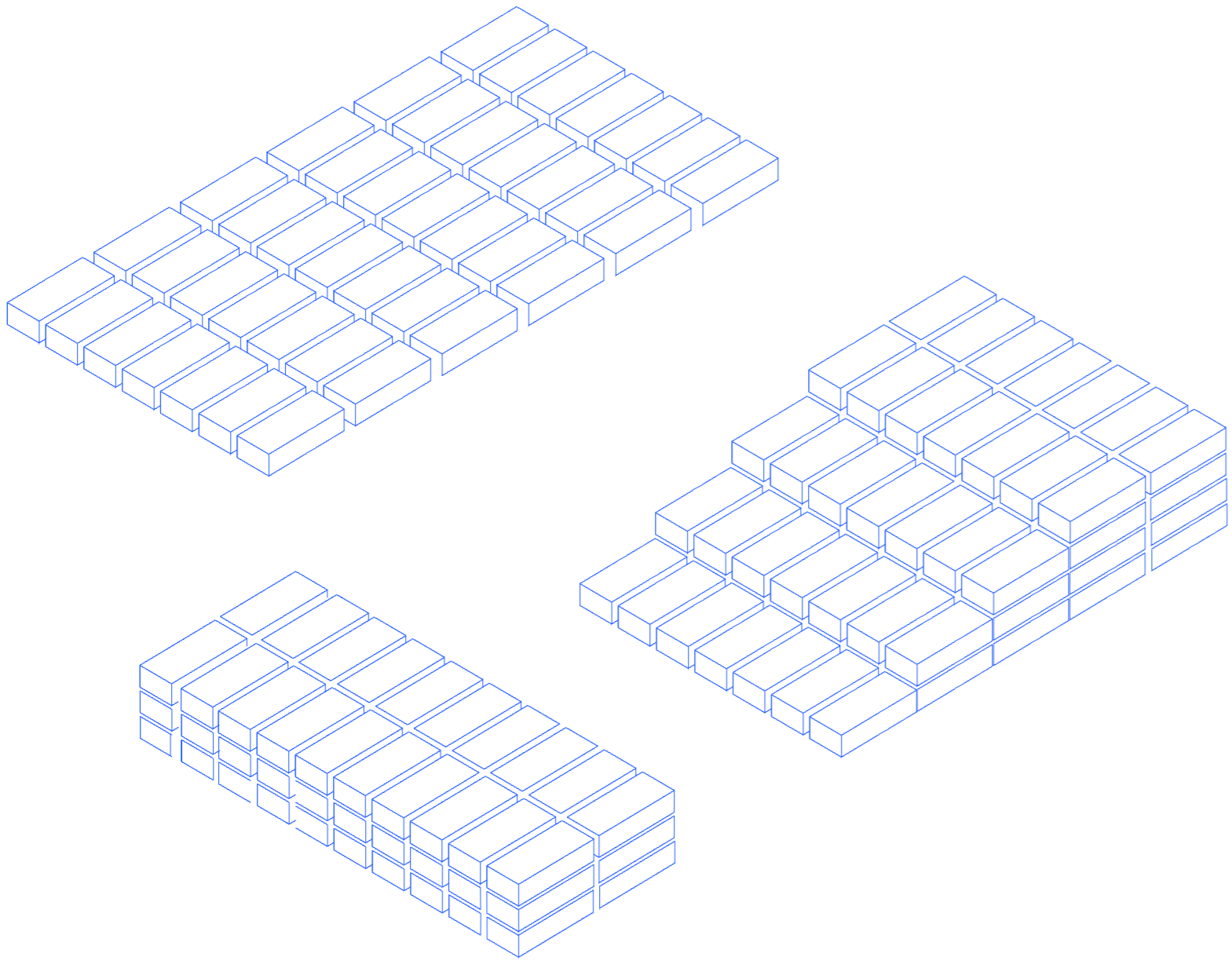

*Habiter par l'intensité*  
*Plan de travail*

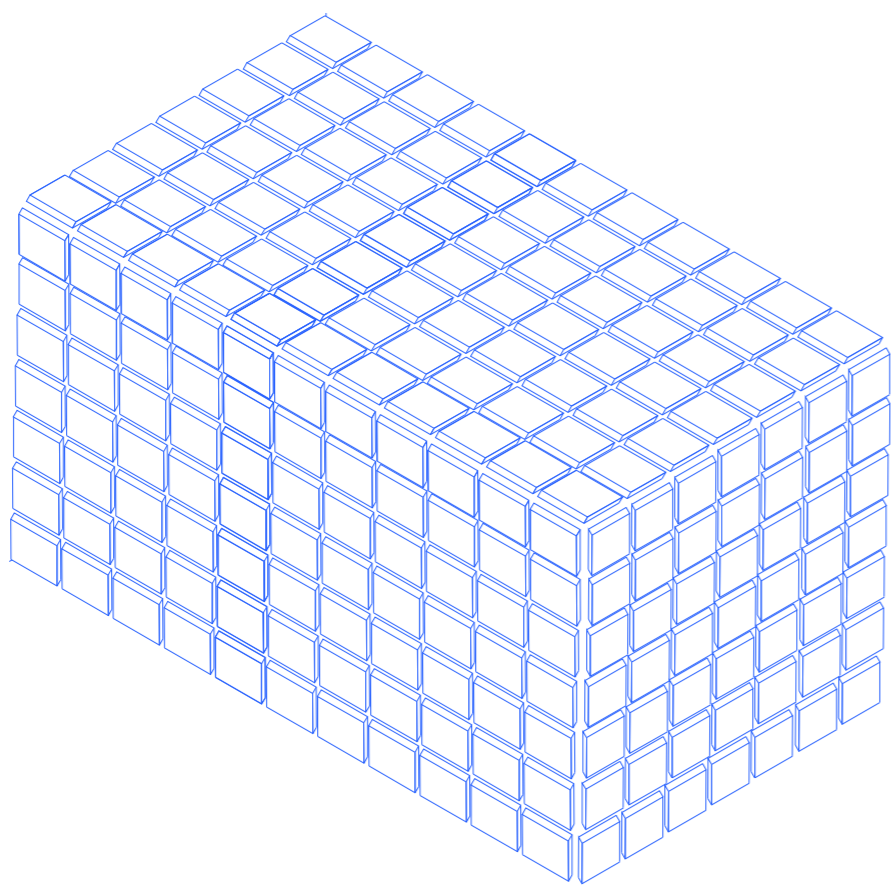

*Habiter par l'intensité*  
*Points d'eau*

