

Principes constructifs

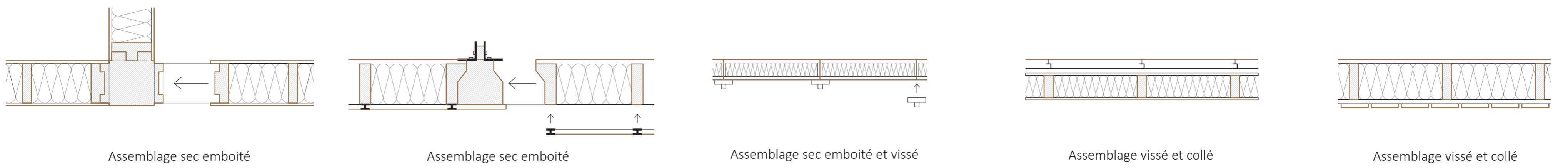

Description des projets



Type
Modules intérieurs dans bâtiment vide

Habitants
Familles en difficulté financière et/ou sociale

Objectif
Hébergement de réinsertion



Type
Modules extérieurs sur terrain vide

Habitants
Sans-abris

Objectif
Hébergement de stabilité



Type
Modules intérieurs dans bâtiment vide

Habitants
Personnes en difficulté

Objectif
Hébergement de réinsertion



Type
Modules extérieurs sur terrains vides

Habitants
Sans-abris

Objectif
Hébergement de stabilité



Type
Modules extérieurs sur terrains vides

Habitants
Sans-abris

Objectif
Hébergement de stabilité

Analyses projets Woonbox et SolidairMobielWonen

SolidairMobielWonen
Dispositions variables

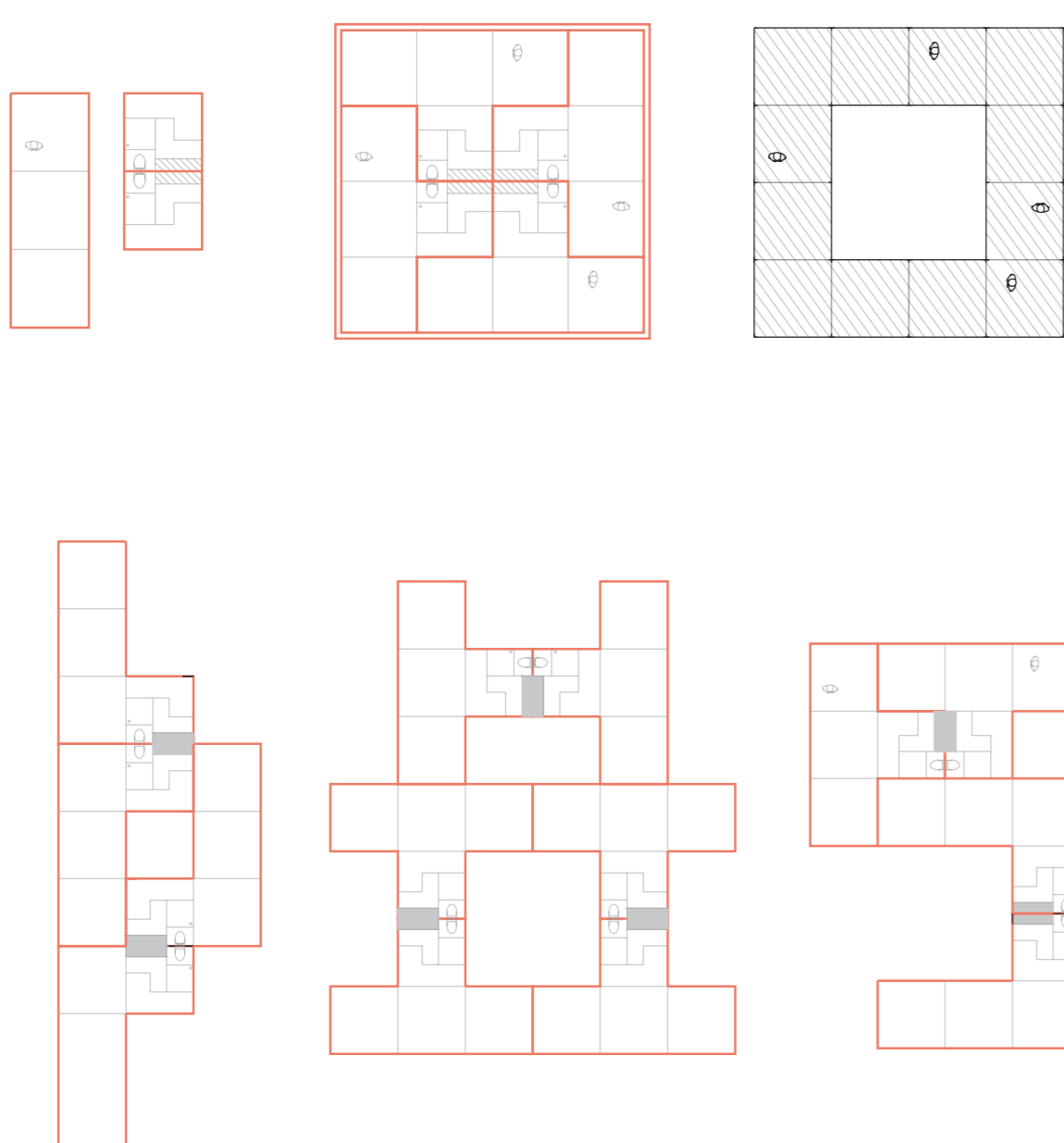

Woonbox
Tailles variables



Mutualisation
Différents degrés de mutualisation des espaces

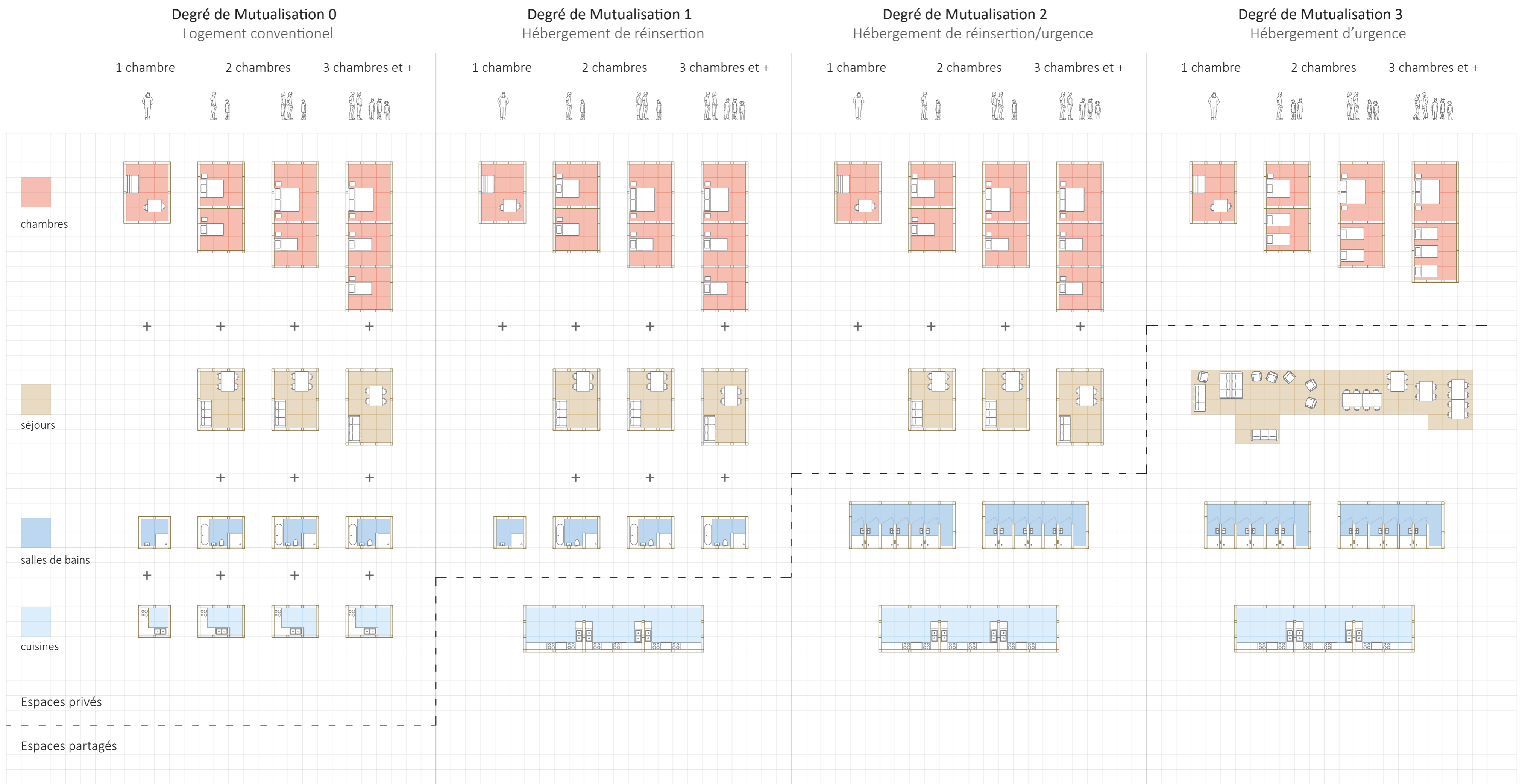

Modularité
Différents aménagements possibles
Rez + 2 de l'ancienne usine pharmaceutique Vesdre Continental à Anderlecht

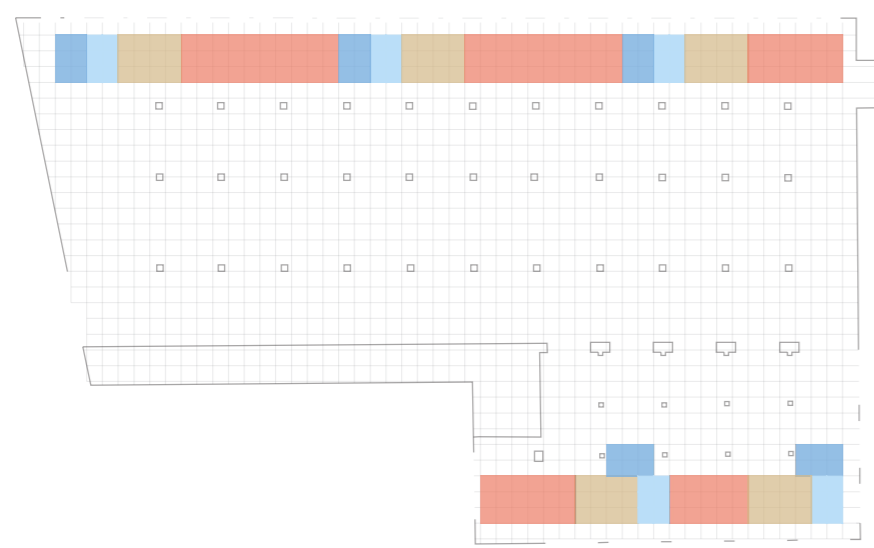

Proposition A degré 0
Logement conventionnel

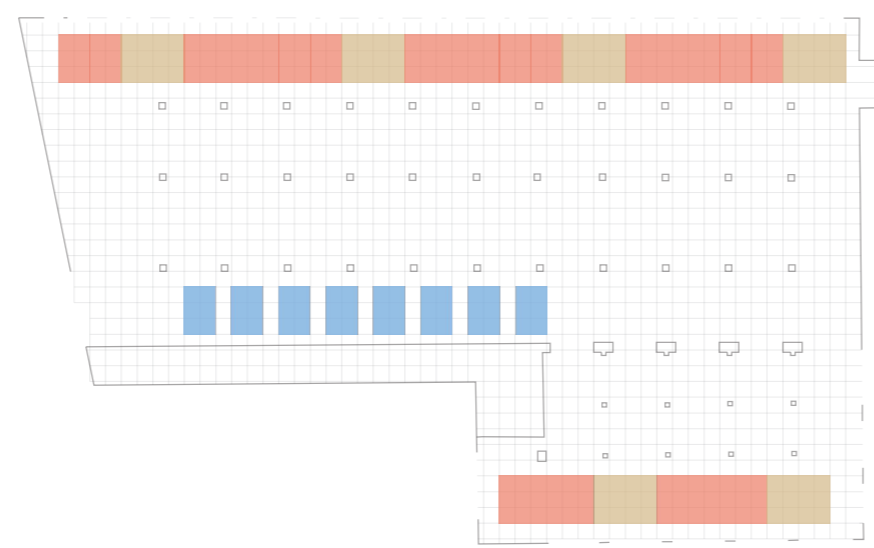

Proposition A degré 1
Hébergement de réinsertion

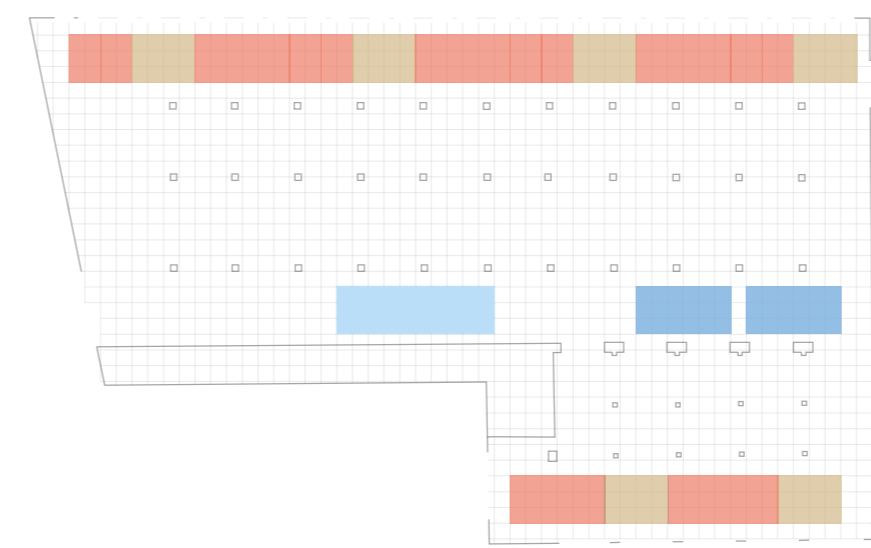

Proposition A degré 2
Hébergement de réinsertion/urgence

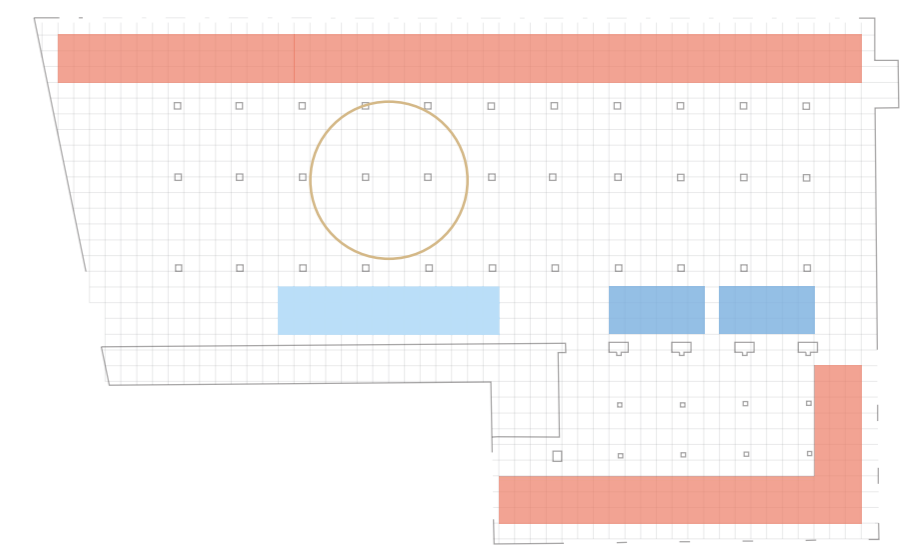

Proposition A degré 3
Hébergement d'urgence

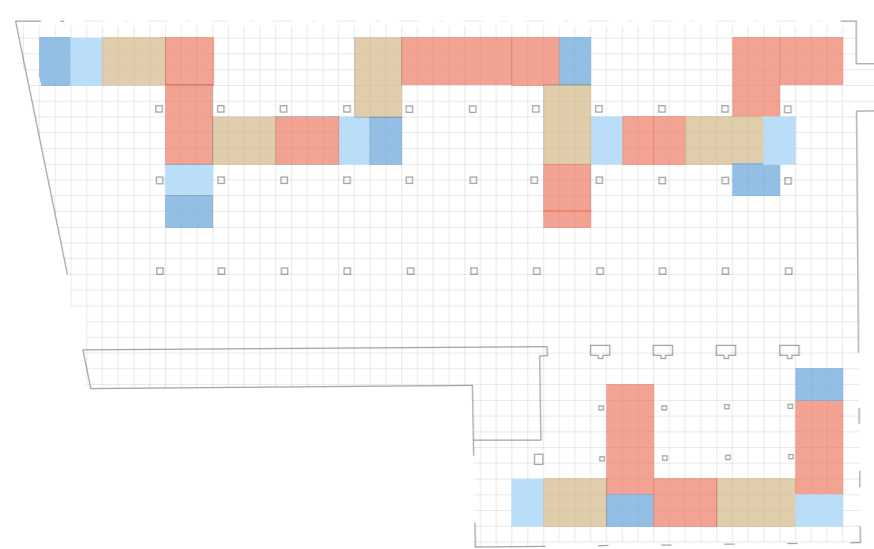

Proposition B degré 0
Logement conventionnel

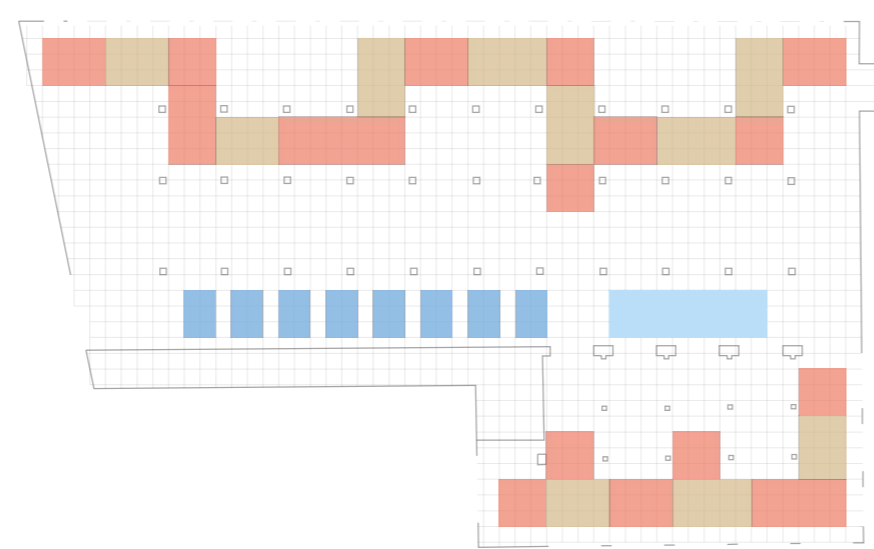

Proposition B degré 1
Hébergement de réinsertion

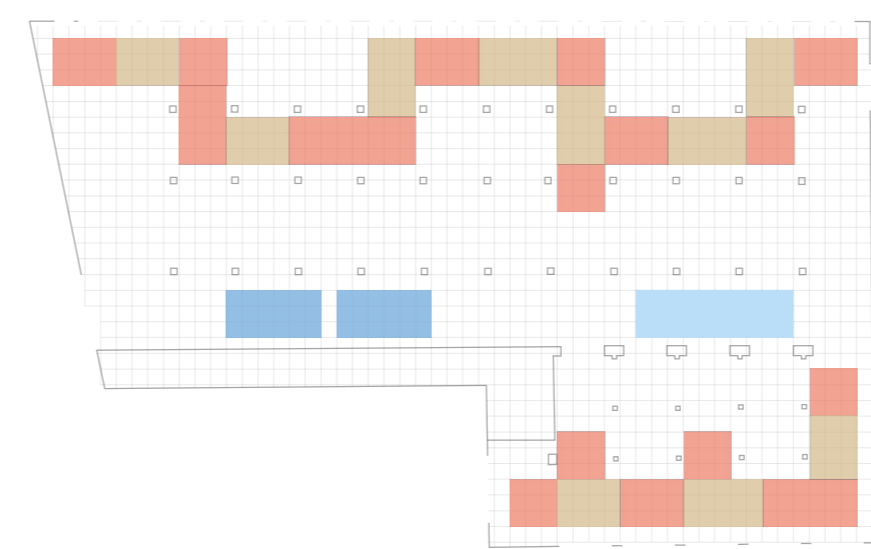

Proposition B degré 2
Hébergement de réinsertion/urgence

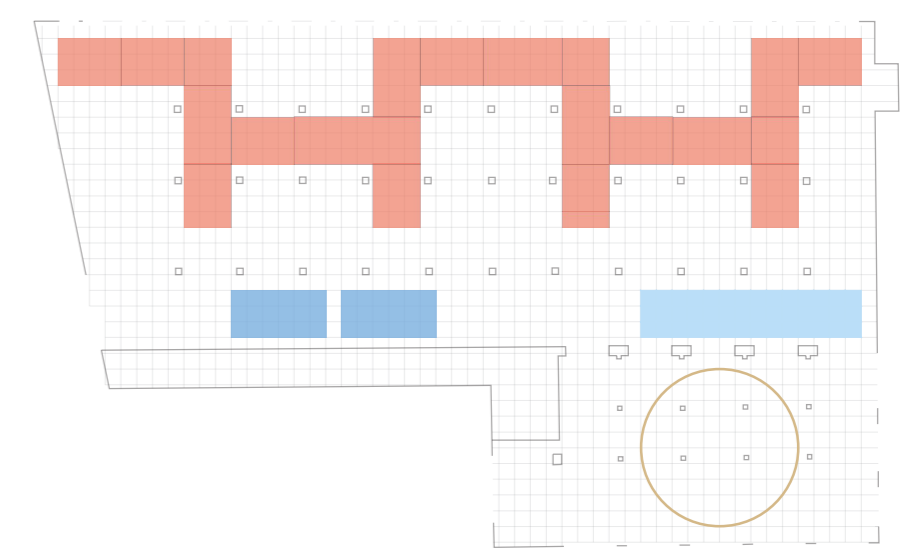

Proposition B degré 3
Hébergement d'urgence

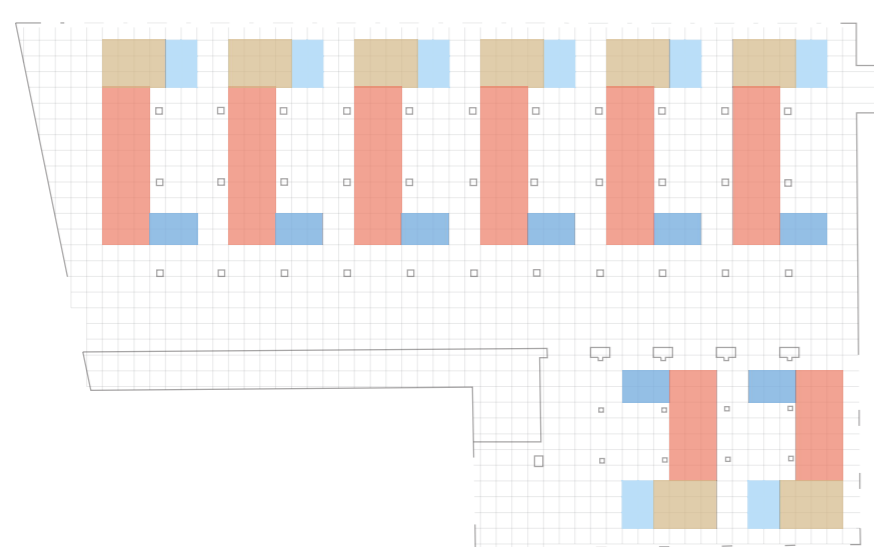

Proposition C degré 0
Logement conventionnel

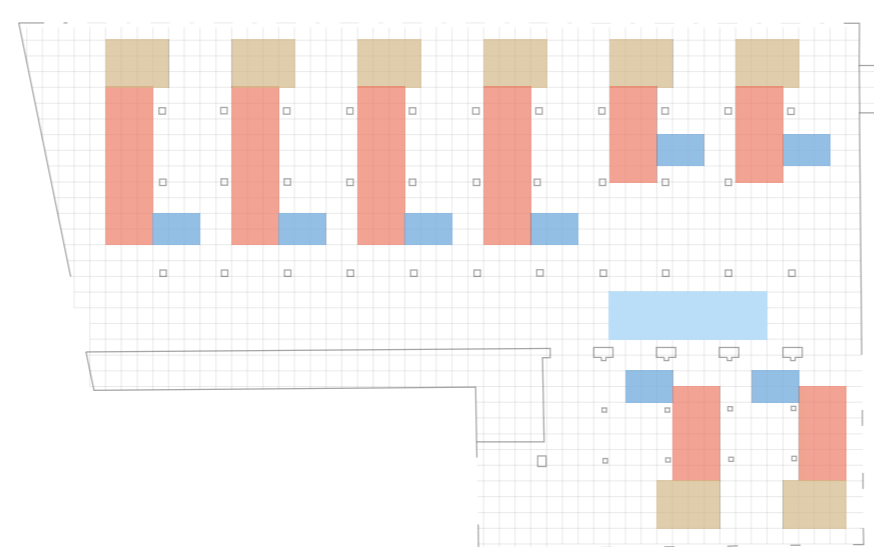

Proposition C degré 1
Hébergement de réinsertion

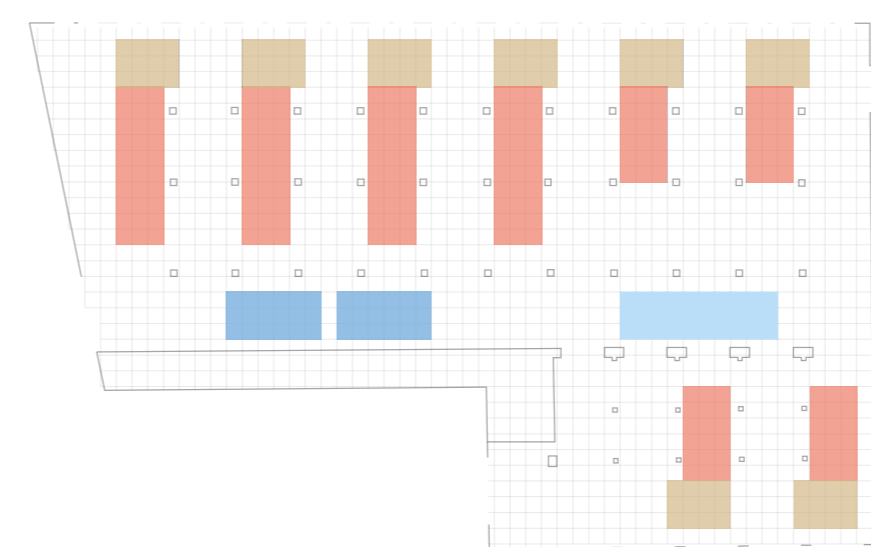

Proposition C degré 2
Hébergement de réinsertion/urgence

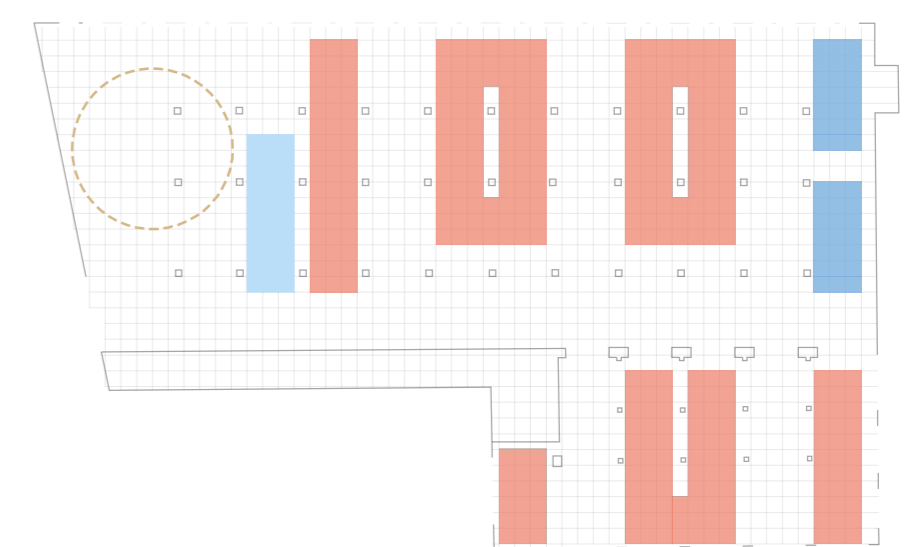

Proposition C degré 3
Hébergement d'urgence



Elevation interieure

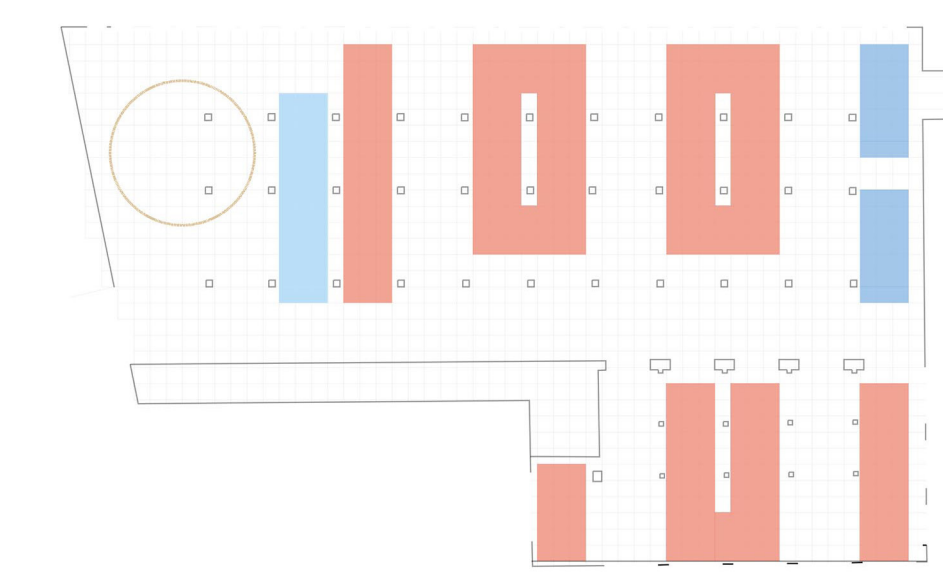
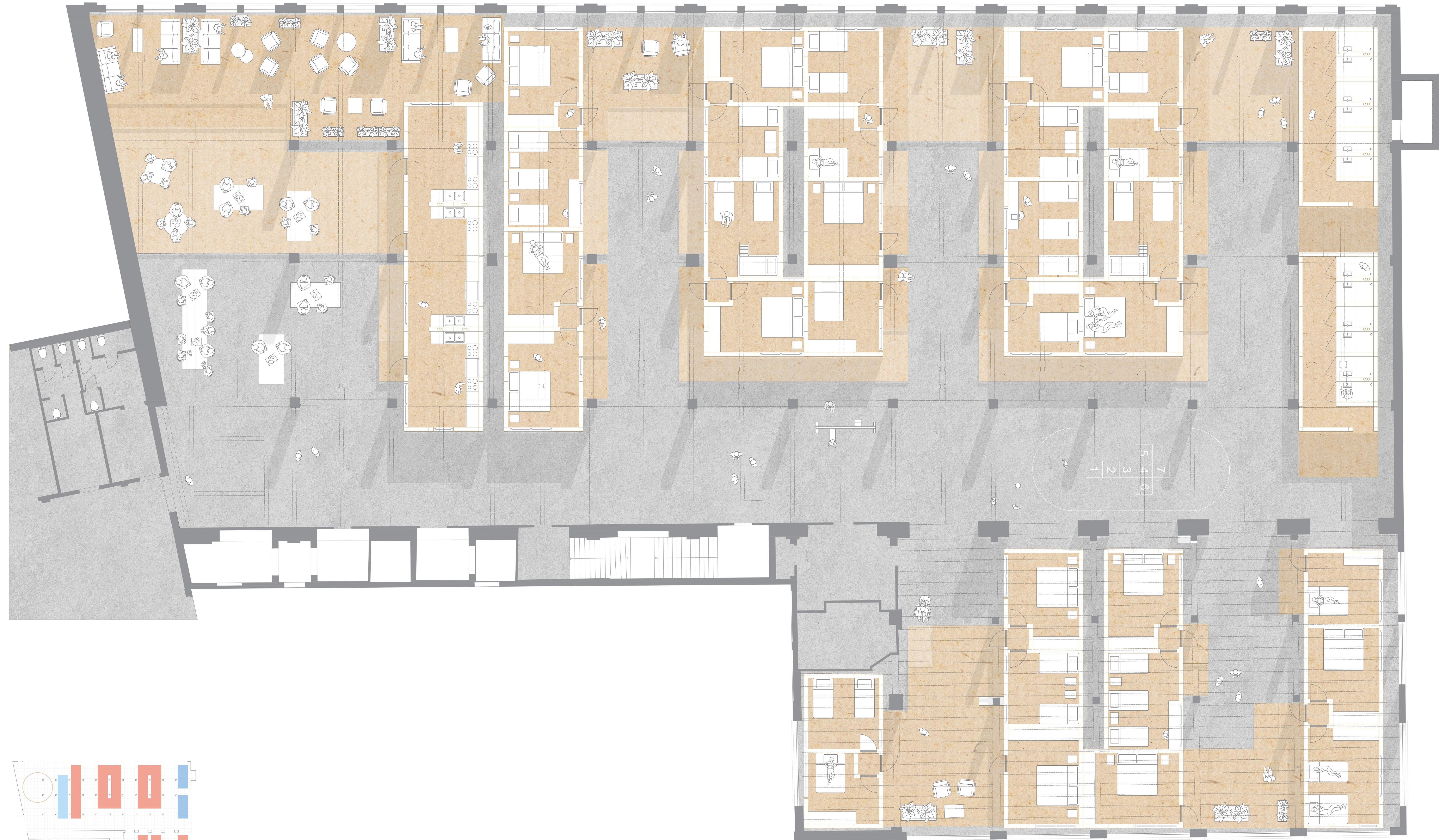

Proposition C degré 3
Hébergement d'urgence

Plan d'aménagement
Rez + 2 de l'ancienne usine pharmaceutique Vesdre Continental à Anderlecht

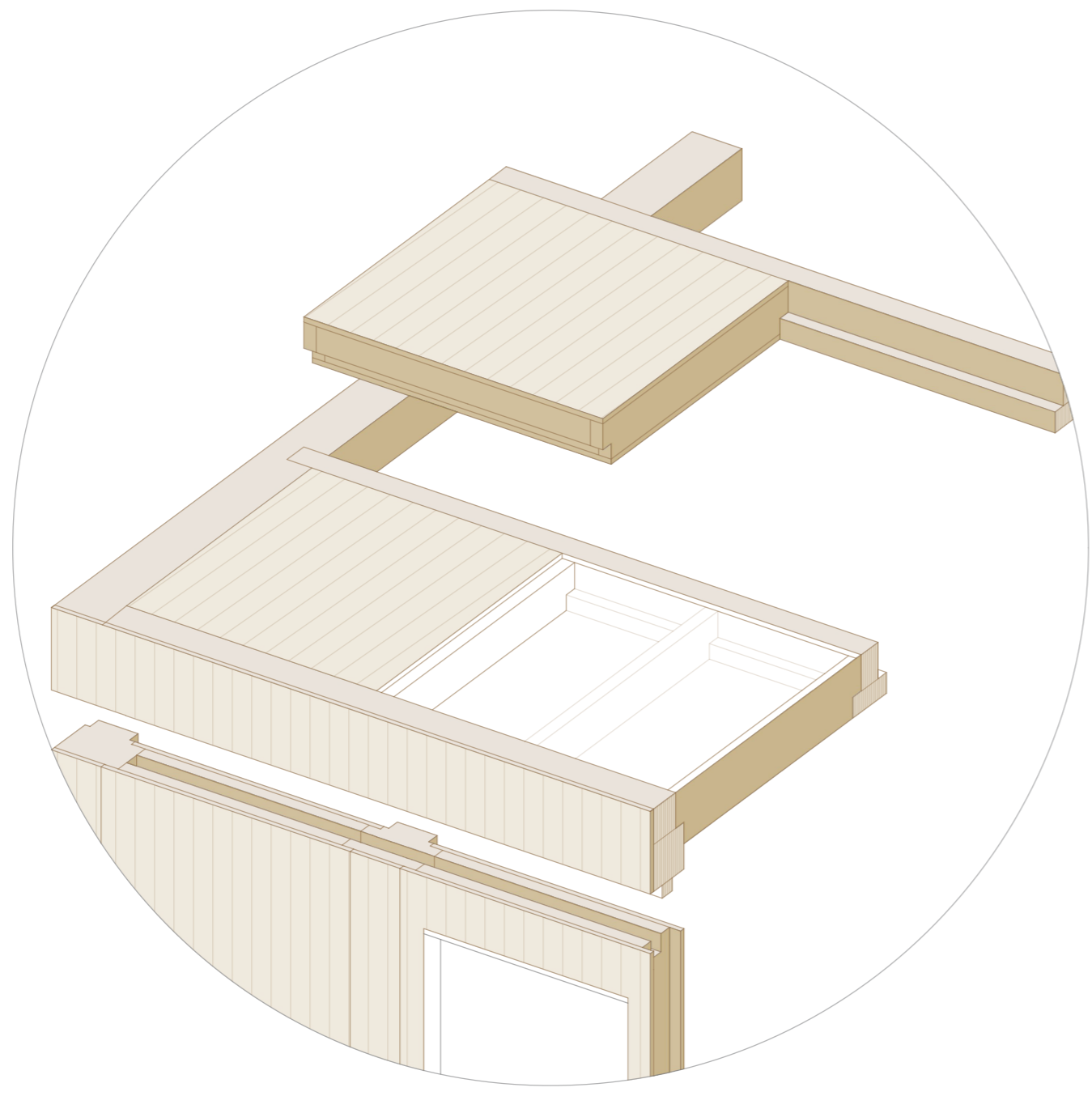

Détail assemblage toit

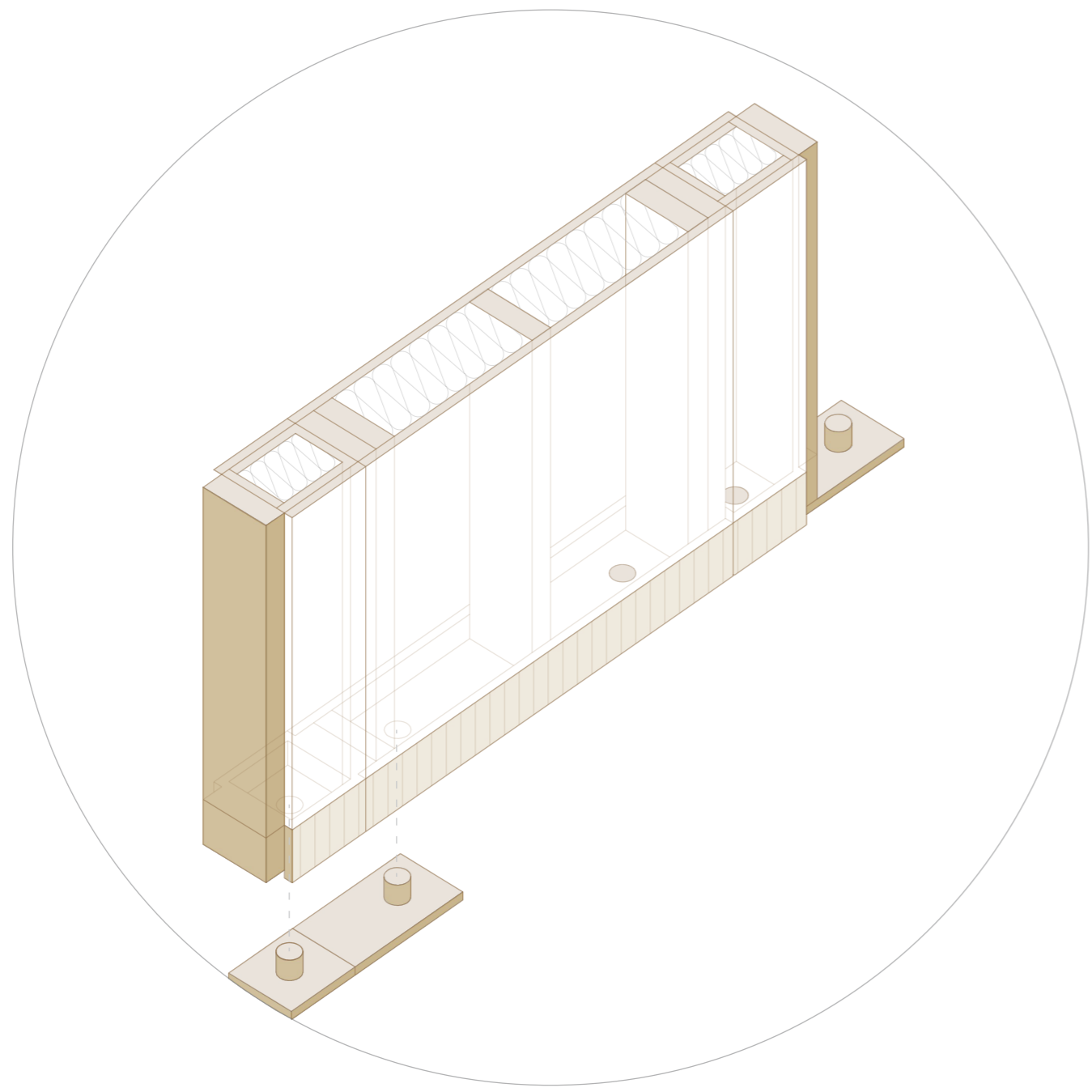

Détail assemblage panneaux

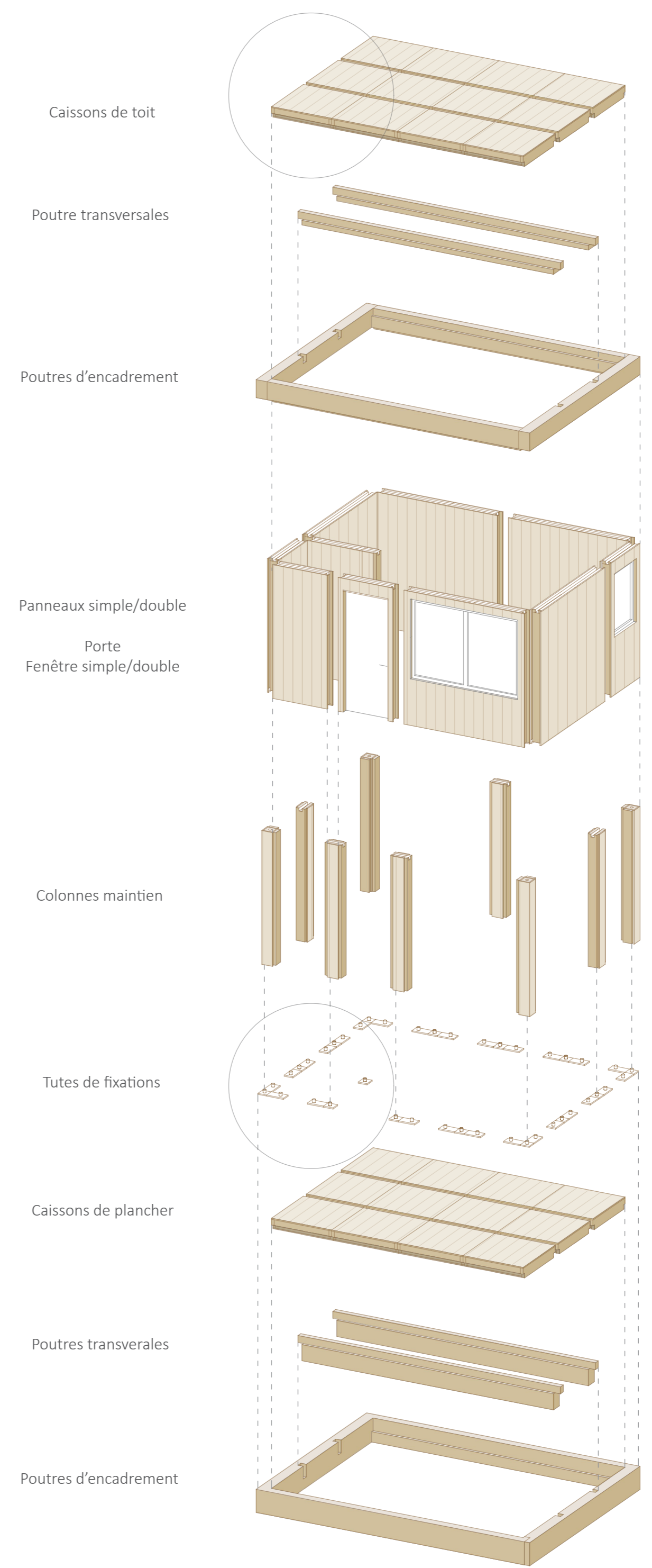

Assemblage complet d'un module

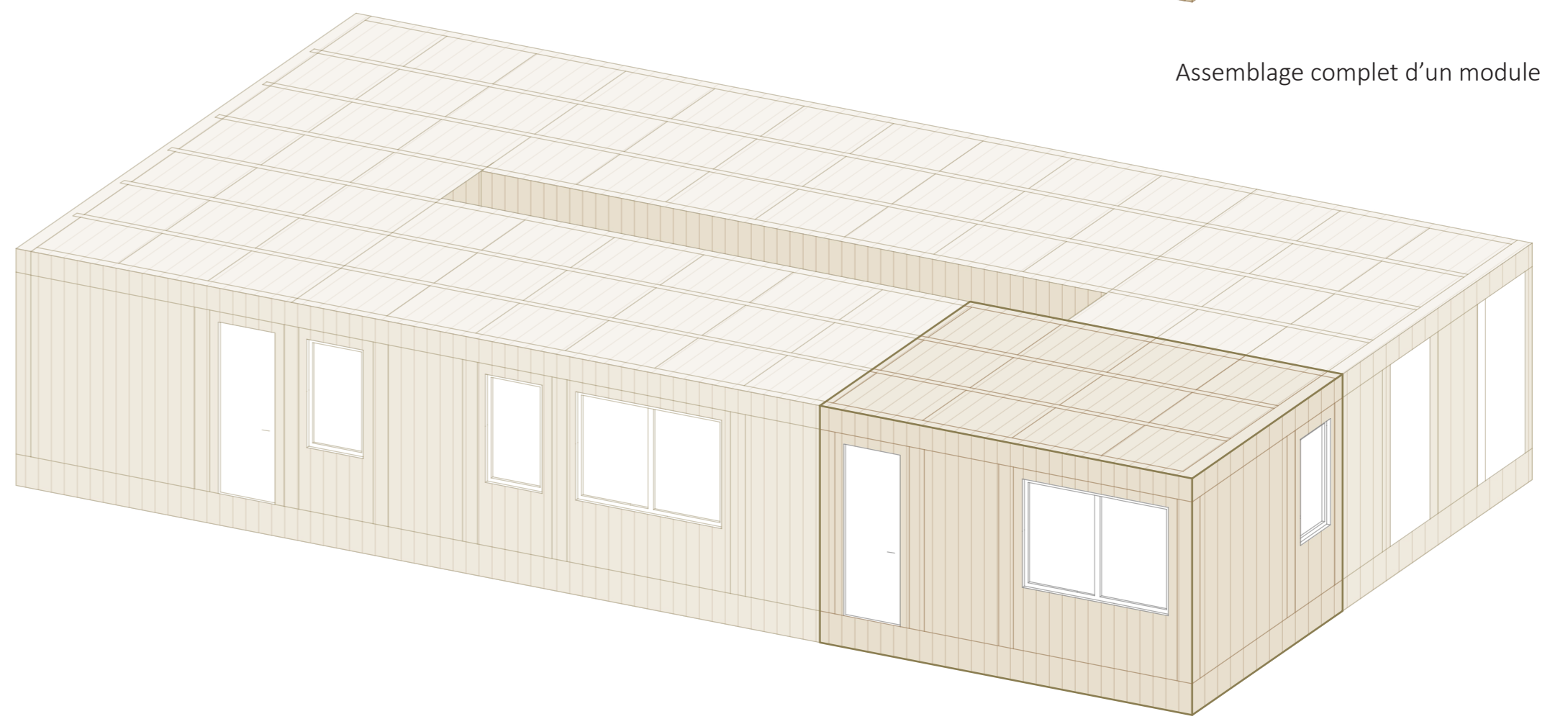

Exemple de combinaison de modules

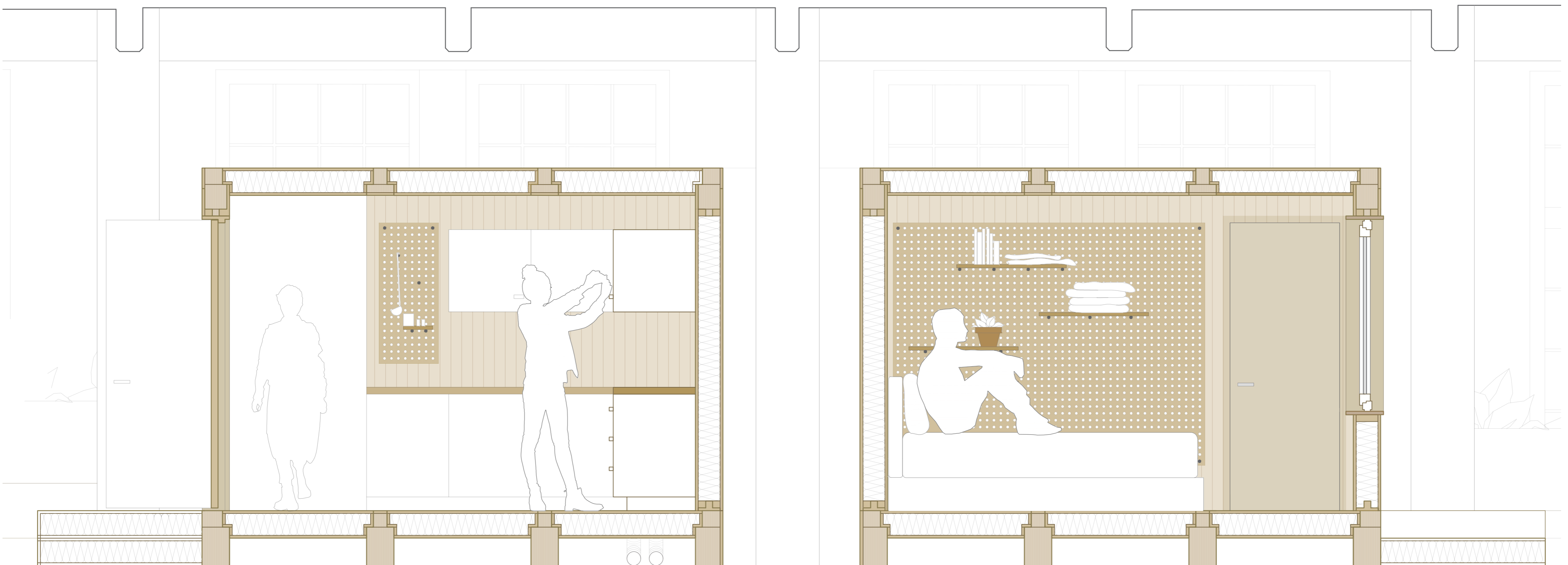

Coupe détail 1:20